

Air Gap Database Configuration and Offset Calculation

Procedure Number: SOP # 3.2.3.5 (E23)

Created By: Seth Baldelli, April 14, 2010

Revised By: Trevor Mackessy-Lloyd, October 31, 2014

Revision Approved By: Manoj Samant, October 31, 2014

Updated By: Minilek Hailegeberel, Thomas Consiglio, May 20, 2019

Approved By: Manoj Samant, May 20, 2019

Updated By: Minilek Hailegeberel, Kristen Falcinelli, October 24, 2019

Updated By: Connor Kishiyama, March 29, 2022

Approved By: Manoj Samant, April 12, 2022

1. **Title:** Air Gap Database Configuration and Offset Calculation

2. **Purpose:**

This SOP was developed to standardize offset calculations and database configuration for air gap systems installed as part of a Physical Oceanographic Real Time System (PORTS®). Air gap systems use several unique database parameters that do not appear in any other measurement system CO-OPS uses. This SOP will familiarize the reader with what those parameters are, how to compute them, and how to properly apply them for data dissemination. This SOP will help enable CO-OPS personnel (primarily COET and DMAT) to fully configure an air gap station for quality control and dissemination.

3. **Background/History:**

CO-OPS' first air gap sensors were deployed in 2003 on the Chesapeake City Bridge (Maryland) and the Reedy Point Bridge (Delaware), both traversing the Chesapeake and Delaware Canal. These first systems consisted of a single microwave water level sensor mounted on the bridge structure to measure vertical clearance from the water surface to the sensor face, with an accuracy of +/- 0.15 m.

Annual maintenance on these sensors originally included trigonometric leveling checks to geodetically connect the air gap sensor to an adjacent water level sensor. In many cases, this was acceptable. However, some bridges experience considerable vertical movement throughout the year from loading conditions and thermal expansion and contraction. Leveling to them once per year does not provide an adequate baseline from which to measure the air gap.

To provide quality-controlled air gap observations from bridges that experience excessive movement (or at sites without adjacent water level gauges) independent air gap measurements were required. These independent observations are performed by a laser air gap sensor. These serve to essentially validate the microwave observations, providing

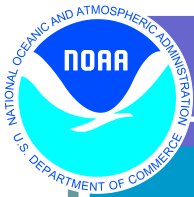

data to determine any long-term sensor drift, abrupt sensor offset, and range-related errors. The laser sensor is installed adjacent to the microwave sensor and has been part of the CO-OPS standard air gap installation since 2008. Having the laser data in conjunction with the microwave data acts as a 24/7 real time QC check. It also provides a more reliable system while eliminating expensive yearly trigonometric leveling checks.

References

- Bushnell, Mark, Kate Bosley and Tom Mero. [*NOAA Technical Report NOS CO-OPS 042 Microwave Air Gap-Bridge Clearance Sensor Test, Evaluation, and Implementation Report*](#). NOAA Technical Report. OSTEP, May 2005
- Bushnell, Mark, Max Ivanov, Warren Krug, Tom Mero, and Brad Wynn. [*NOAA Technical Report NOS CO-OPS 049 Initial Operational Deployment Report Miros Air Gap Sensor and Laser Sensor at the Verrazano-Narrows Bridge*](#). NOAA Technical Report. OSTEP, September 2009
- [*Air Gap Field Installation Guide*](#). NOAA Manual. OSTEP, April 2010
- Heitsenrether, Robert, and Winston Hensley. [*Test and Evaluation Report for WaterLog® H-3612 Radar Sensor in CO-OPS Air Gap Applications*](#). NOAA Technical Report. OSTEP, January 2013.

4. **Scope/Applicability:**

This SOP describes the calculation of offsets that are entered into the database by both the Configuration and Operational Engineering Team (COET) of the Engineering Division and the Data Monitoring and Assessment Team (DMAT) of the Oceanographic Division. Both teams shall utilize this SOP to declare new air gap systems operational, as well as to execute day-to-day tasks related to air gap station maintenance and operation.

5. **Main Processes:**

The first step to ingest air gap data is for COET to configure the station in Data Processing and Analysis Subsystem PowerBuilder (DPAS PB), generally following the procedure for configuring a new NWLON water level station (see CO-OPS SOP [*Database Configuration of National Water Level Observation Network \(NWLON\) Water Level Stations*](#)). The differences in configuration are explained in detail below.

A standard air gap installation consists of a single DCP with primary and independent air gap sensors. The primary sensor is either an approved Miros microwave air gap sensor or a WaterLog microwave sensor. The independent air gap sensor is a Laser Technology, Inc. (LTI) laser air gap sensor. Depending on how the sensors are physically mounted to the bridge, the primary sensor may be located above or below the laser sensor.

When an air gap station using a Miros sensor is configured, and data is ingesting for both sensors, COET shall determine the preliminary 'AG_CAL_OFFSET' as explained in section 6: Detailed Sub-Processes/Checklists below. This parameter is set to '0' for WaterLog sensors.

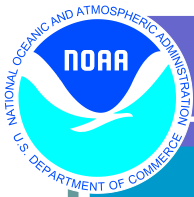

DMAT will then verify the calculation. DMAT is also responsible for calculating and configuring the AG_MAX, AG_MIN, AG_ROFC, and AG_SIGMA station parameters.

The parameters listed below will be explained further in the detailed sub-processes:

Sensor Parameters:

- AG_LS_OFFSET
- AG_CAL_OFFSET (Miros)
- SENSOR_OFFSET (WaterLog)
- AG_LP_TO_LS_CHECK

Station Parameters:

- AG_MANUAL_ADJUSTMENT (0.000 m)
- AG_MAX
- AG_MIN
- AG_ROFC (usually set to 0.150 m)
- AG_SIGMA (usually set to 0.200 m)
- MEAN_AG_WL_OFFSET

6. Detailed Sub-Processes/Checklists:

Low Steel Elevation & Station Installation

Prior to installation and configuration of a new air gap station, the PORTS Partner must identify and or agree upon the official lowest steel structure on the bridge the air gap sensors will be referencing. Ideally, the Low Steel elevation is the lowest permanent structural component of the bridge where the air gap sensor measurement is reported for PORTS products. However, the PORTS Partners on occasion do identify other components that are not the lowest structure but are treated as such for data referencing. The air gap sensor is generally installed at the center of the navigation channel, but many times the Low Steel may be located some distance away from the sensor location.

PORTS Partners, Port Authority personnel, local pilots, US Coast Guard, or other stakeholders, shall determine the low steel structure and location used in the calculation of the Low Steel elevation. PORTS Manager and Task Representative are included in communications regarding the determination of the Low Steel elevation with the PORTS Partner. Therefore, PORTS Manager and Task Representative must communicate the desired location and measurement of the Low Steel structure in an email to COET (nos.coops.oetteam@noaa.gov) for proper database configuration and for documentation. This email shall serve as a validation for COET that CO-OPS and the PORTS Partners have agreed on the structure to which the air gap sensors will reference as the Low Steel elevation.

COET shall document the agreed upon measurement from the sensor leveling point to the Low Steel elevation and a descriptive text of the Low Steel location on the bridge via a letter or email from the PORTS Partner and include the written confirmation in the station package

During the sensors installation, the field personnel shall measure the heights of the sensor leveling points (as shown in Figure 4 and Figure 5) using the agreed upon Low Steel elevation as a reference elevation. The sensor leveling point is the physical point on the sensor from which the observed distance is measured—correct measurement of this point is critical to properly calculate and disseminate the air gap data. The sensor leveling point for the Miros is the green face of the sensor while the Laser sensor lens is the leveling point for the Laser sensor. Both Miros and the Laser sensor do not have a sensor offset. The WaterLog microwave sensor has a mounting collar where a leveling notch can be found and is the leveling point. The WaterLog has a manufacturer provided sensor offset. These measurements shall be included with the installation documentation submitted to COET, necessary to calculate and configure the sensor parameters described below.

The low steel measurement is the distance from the sensor leveling point to the low steel elevation. It can be measured using tape down and line of sight measurements, or trigonometric leveling, which is explained in section 3.26 of the User’s Guide to Vertical Control and Geodetic Leveling for CO-OPS Observing Systems.

Air Gap Station Configuration

Using information provided by the PORTS Partner, COET will pre-configure the Station record in DPAS PB. COET will pre-configure a dummy DCP and the appropriate sensors (microwave sensor Q1, laser sensor Q2) with dummy serial numbers, to be replaced by the field crew using eSite report when the installation documentation is submitted. The DCP record shall be given a Project Code “O”. COET will configure the transmission parameters as provided by the instrument lab.

Once the equipment has been configured in the database, COET will set the microwave (Q1) and laser (Q2) sensor parameters and station parameters as described below.

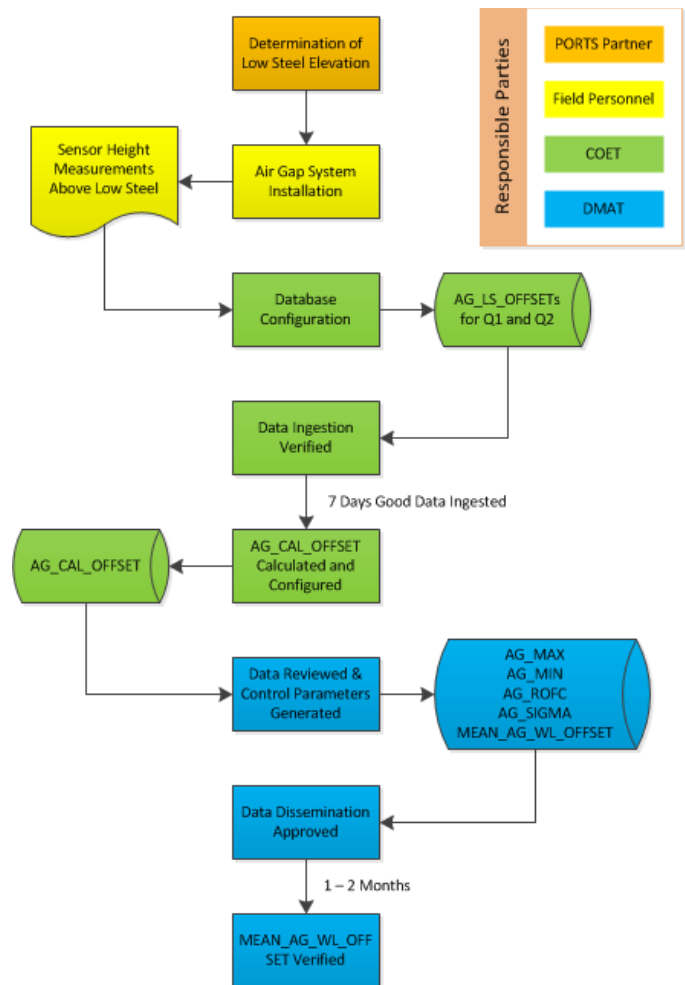

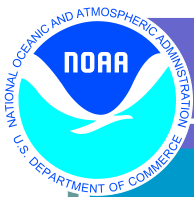

AG_MANUAL_ADJUSTMENT

Prior to 2014, CO-OPS applied a 'manual adjustment' of 0.152 m (6 inches) to both sensors (Q1 and Q2) as a safety factor to account for sensor error and uncertainties.

In September 2014, CO-OPS' policy was changed, and the manual adjustment for all air gap systems was no longer applied to the raw data. Presently, the stored procedures using this parameter have not been modified to account for this policy change. Until that is complete, COET will need to set this station parameter to zero for all new air gap stations. If this zero value is not inserted for the AG_MANUAL_ADJUSTMENT parameter, the stored procedures will read a null value for the parameter, and the data may not plot in certain interfaces and products (because AIR_GAP_ADJ will not be calculated).

AG_LS_OFFSET

AG_LS_OFFSET is a database parameter that describes the Sensor Zero relative to Low Steel. It is the vertical offset of the sensor zero relative to a Low Steel value on the bridge as designated by the PORTS Partner. This parameter is used by ingestion to calculate the air gap between the Low Steel location and the raw observed distance to the water surface.

The Low Steel elevation shall be determined prior to station installation. Once the Low Steel offsets are determined, the field personnel shall provide COET a sensor elevation diagram with the installation documentation that includes the distance from each sensor leveling point to Low Steel. The SENSOR_OFFSET must be included in the drawing if a WaterLog sensor is installed.

The measurement for each sensors' leveling point shall be made as follows:

- Miros – measure directly to the green face of the sensor.
- WaterLog H3612 – measure from the **top** of the geodetic collar. The collar is marked by a notch to indicate the leveling point.
- Laser Tech – measure directly to the lens of the laser sensor (not the outer protective case).

The AG_LS_OFFSET is the sensor zero relative to low steel. To define the sensor zero, the SENSOR_OFFSET must be accounted for in the Low Steel parameter. The ingestion system does not factor in a SENSOR_OFFSET parameter for air gap sensors. Therefore, **COET will need to subtract the SENSOR_OFFSET from the Leveling Point to Low Steel measurement and enter the value as the AG_LS_OFFSET sensor parameter in DPAS PB.** COET will then enter the parameter SENSOR_OFFSET in DPAS PB so that the offset can be documented and can be queried when needed. Both the Miros and the

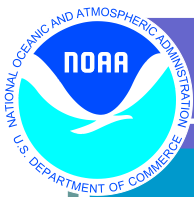

Laser sensors do not have a SENSOR_OFFSET. However, the data ingestion protocols require a SENSOR_OFFSET parameter configured, therefore COET must enter 0.000 meter in DPAS PB for Miros and the Laser sensor.

$$\text{AG_LS_OFFSET} = (\text{Leveling point to Low Steel elevation}) - (\text{SENSOR_OFFSET})$$

The AG_LS_OFFSET for each sensor shall be configured following submission of the installation documentation. After initial configuration, subsequent maintenance documentation regarding a sensor offset change due to a sensor swap or an adjustment to the measured values may require updating of the AG_LS_OFFSET. If the sensor offset change causes the AG_LS_OFFSET to change by +/- 1 cm following a sensor swap, inform the PORTS Program Manager and begin updating the Air Gap Notice Letter to inform stakeholders. Due to the 2 cm error tolerance of air gap systems, a 1 cm shift is considered the threshold to notify PORTS Partners by the PORTS Program Manager. The requirements for the Air Gap Notice Letter are described in a later section of this SOP. Usually, re-measuring from Low Steel elevation to the sensors is not needed. The sensors are typically installed on bridges and cannot be accessed/tampered with easily. Movement of the sensors is not typically expected. To mitigate the risk of improperly referenced sensor readings, PORTS Manager and Task Representatives must urge PORTS Partners to communicate bridge construction/repair work that will effectively change what has been agreed upon as Low Steel location. If a lower structure is installed (e.g., navigational lights or beacons) below the agreed upon Low Steel elevation, PORTS Partners must notify CO-OPS and ask to re measure from sensor to the new Low Steel location. Data dissemination must be turned off until new measurements can be entered by COET.

AG_CAL_OFFSET

The AG_CAL_OFFSET is an additional adjustment made to the Miros sensor's manufacturer calibration that is separate from the installed vertical difference between both sensors. This offset will adjust the Miros readings to agree with the real time check from the Laser sensor. Through extensive testing by the Ocean System Test and Evaluation Program (OSTEP), this adjustment was required for all Miros sensors to account for various environmental and sensor factors (described in NOAA Technical Report NOS CO-OPS 042 and 049). WaterLog sensors have proven accuracy, so they do not require an AG_CAL_OFFSET but must be configured in the database with this parameter. Presently, this offset must be entered for WaterLog sensors with a value of 0.000 meters to enable the calculation of AIR_GAP_ADJ, similar to the AG_MANUAL_ADJUSTMENT station parameter.

After the AG_LS_OFFSET is configured, installation documentation is accepted, and data ingestion has been confirmed, COET can proceed with calculation of the AG_CAL_OFFSET. Computation of the AG_CAL_OFFSET offset requires at least seven continuous days of data collection. 75% of the data from both sensors for this

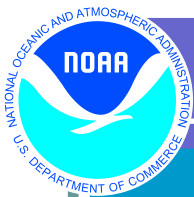

collection period must be present in the database in order to compute an accurate offset. It is crucial that the computation of this offset be done consistently among COET and DMAT. The data will need to be manually filtered using the established rate-of-change and sigma limits (0.20 m and 0.15 m, respectively) to remove spikes in the data caused by vessels passing beneath the sensors.

Once the minimum length of data are available, simply compute the mean difference between the primary sensor and laser sensor (Q1 – Q2) data sets. The average difference between the primary sensor and laser sensor data sets over the duration of the time period is then used as the AG_CAL_OFFSET value for the Q1 (Miros sensors only), effectively adjusting the data from the primary sensor to the data from the laser sensor.

The AG_CAL_OFFSET must be set to zero for the Laser sensor (Q2). The Laser sensor is not to be adjusted; however, the ingestion protocols require the AG_CAL_OFFSET be configured.

The purpose of the AG_CAL_OFFSET is to adjust the Miros sensor data, correcting for environmental influences, it is possible for this offset to have a positive or negative value. The AG_CAL_OFFSET will be subtracted from the raw Q1 observation to generate the adjusted air gap value, so if the AG_CAL_OFFSET is positive, the adjusted air gap value will be reduced. It is important to have a clear understanding of how this offset will impact the adjusted air gap data to ensure proper calculation.

After COET has calculated the AG_CAL_OFFSET, DMAT will review the proposed value, as well as the start and end timestamps of the data series used to calculate it. DMAT shall validate the value by independent calculation, using the same data series. This verification shall occur prior to confirming data quality or determining the QC parameters described below. COET shall configure the AG_CAL_OFFSET parameter upon DMAT confirmation.

AG_LP_TO_LS_CHECK:

AG_LP_TO_LS_CHECK is the relationship between the sensor leveling point and low steel. It is frequently referenced for liability and metadata review so it is important to store this value in the database so it can be easily found by users.

This value is similar to AG_LS_OFFSET, but the sensor offset is not used in calculating this parameter. AG_LP_TO_LS_CHECK is configured for Miros, WaterLog, and Laser sensors but is not applied to the data during the ingestion process. Since the Miros and Laser sensors do not have sensor offsets, AG_LP_TO_LS_CHECK should equal the exact measurement of the AG_LS_OFFSET. The AG_LP_TO_LS_CHECK is calculated by measuring the distance from the sensor leveling point to low steel, and is recorded on the sensor elevation drawing. The leveling points on each sensor have been described in the AG_LS_OFFSET section.

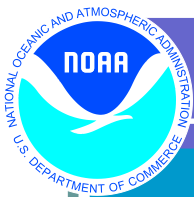

Figure 1: Air Gap Sensor Parameters

Station	8519461					Change...
DCP#	1	Sensor	Q1 - AIR GAP			
Parameter	Value	Begin Date	Used	Present	Entered By	
ACCEPT_DATUM_OFFSET	.0000	07/07/2011 00:00	Yes	Yes	Hailegeberel, Minilek / 07/07/2011 14:03	
ACCEPT_SENSOR_OFFSET	-.0020	02/14/2019 16:00	Yes	Yes	Glassmire, Kirk / 02/14/2019 21:22	
AG_LS_OFFSET	1.1980	02/14/2019 16:01	Yes	Yes	Glassmire, Kirk / 03/01/2019 20:59	
AG_CAL_OFFSET	.0000	02/14/2019 16:00	Yes	Yes	Glassmire, Kirk / 02/14/2019 21:11	
AG_LP_TO_LS_CHECK	1.2000	02/14/2019 16:01	Yes	Yes	Spore, James / 03/12/2020 16:27	

Data Ingestion and Calculation of AIR_GAP_ADJ

The raw air gap measurements are currently recorded in the DPAS database, in the AIR_GAP column of the AIR_GAP table. Time series plots of Q1 and Q2 data generated by WALI use the raw measurements from this column and do not automatically apply any of the offset parameters.

Once the AG_MANUAL_ADJUSTMENT, AG_LS_OFFSET, and AG_CAL_OFFSET parameters have been entered into the database, the data ingestion system will begin to calculate and insert the adjusted air gap measurement into the AIR_GAP_ADJ column in the AIR_GAP table of DPAS. The adjusted air gap value is calculated by subtracting all three offsets from the raw air gap observation. The stored procedure subtracts all values, so be certain to enter the correct notation.

During data ingestion, the adjusted air gap data will be calculated and inserted in the database using the raw air gap measurement (AIR_GAP) and the above parameters using the below formula:

$$AIR_GAP_ADJ = AIR_GAP - AG_CAL_OFFSET - AG_LS_OFFSET - AG_MANUAL_ADJUSTMENT$$

Both the AIR_GAP_ADJ and AIR_GAP values are stored in the database table OceanData.dbo.WL_AIR_GAP and the AIR_GAP_ADJ data is what is displayed on real-time PORTS data products.

Example:

8517986 Verrazano-Narrows Bridge Air Gap, measurement at 11/30/2008 09:36

Q1 AIR_GAP	73.088 m	
(AG_MANUAL_ADJUSTMENT)	- 0.000 m	
(Q1 AG_LS_OFFSET)	- 2.620 m	
(Q1 AG_CAL_OFFSET)	<u>- 0.146 m</u>	(Miros installed)
Q1 AIR_GAP_ADJ	70.322 m	
Q2 AIR_GAP	72.903 m	
(AG_MANUAL_ADJUSTMENT)	- 0.000 m	
(Q2 AG_LS_OFFSET)	- 2.633 m	
(Q2 AG_CAL_OFFSET)	<u>- 0.000 m</u>	
Q2 AIR_GAP_ADJ	70.270 m	

Figure 2: Calculation of AIR_GAP_ADJ

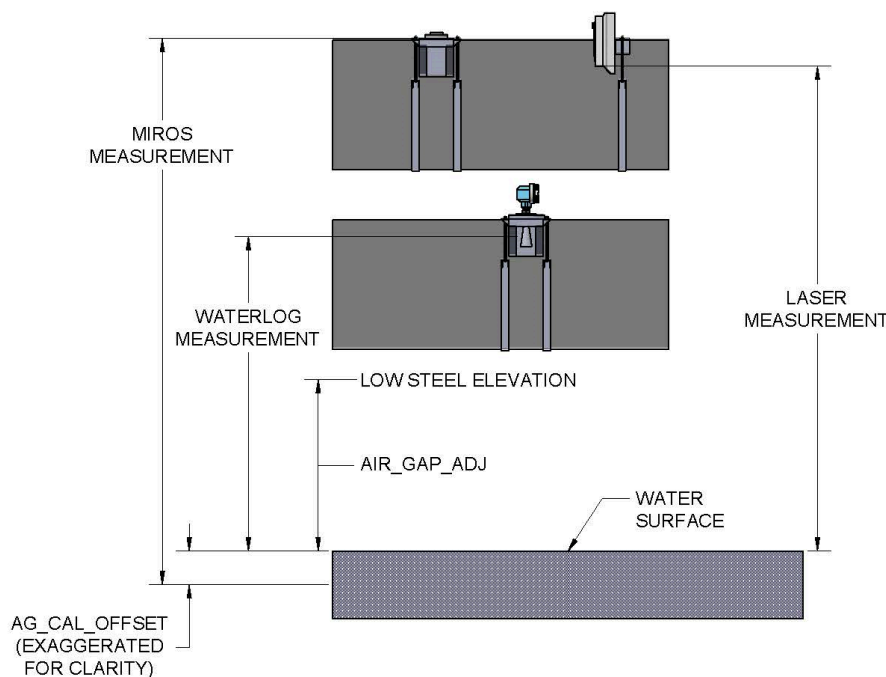

The DiagTool uses the AIR_GAP_ADJ values for Q1 and Q2 data, making it a useful interface for confirming that the calculations are correct.

The station parameters mentioned below are presently the responsibility of DMAT:

AG_MAX & AG_MIN

This is the quality control parameter so that quality checks can be done on air gap data. DiagTool and disseminated PORTS data will disregard values greater than the AG_MAX

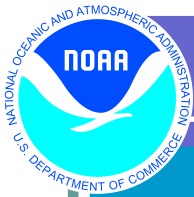

value and less than the AG_MIN value. To compute these values, at least 7 days of data are required, however, 30 days or more is preferred.

DMAT is responsible for computing these values. When an air gap station begins transmitting, raw data is immediately available for plotting in DiagTool. A DMAT reviewer will use this to determine the station's AG_MAX and AG_MIN values by monitoring the time series curve. An additional 1.0-2.0 meter buffer is added to each side, to allow for storm event flexibility.

Once these parameters are entered into DPAS PB, the "QC filter" option on DiagTool will become functional. When utilized, DiagTool plots "clean" air gap data with spikes and erroneous data points removed from the curve.

AG_ROFC

The air gap rate of change coefficient was determined by CO-OPS oceanographers to be a value of 0.15 m. This value is entered into DPAS PB station parameters. This QC parameter throws out any sensor data points that differs by greater than 0.15 m from the previous 6 minute value.

AG_SIGMA

The 'AG_SIGMA' is the maximum allowable sample-standard deviation. The standard value for CO-OPS data is 0.20m, which has proven to correctly flag suspect data (such as a ship passing directly below the sensor) based on many previous years of analyses. All air gap sensors presently use this value--any observed data point exceeding this threshold will be flagged and not disseminated. This value is entered as 0.20 m as a DPAS PB station parameter.

MEAN_AG_WL_OFFSET

The 'MEAN_AG_WL_OFFSET' is a derived value that acts as a secondary QC check, by allowing for a direct comparison of air gap data to nearby water level station data. The adjusted air gap data is negated (inverted) subtracted from water level data from a nearby station. A DMAT reviewer then calculates the mean difference between the two curves on MLLW, and this becomes the parameter value. Computation of this value is DMAT's responsibility.

Three months after initial calculation and as needed thereafter, DMAT will rerun the calculation to refine or verify the value.

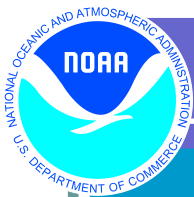

Figure 3: Air Gap Station Parameters

Station

Parameter	Value	Begin Date	Entered By
AG_MAX	72.200	01/01/2000 00:00	Bourgerie, Richard - 8/10/2009 11:51:41
AG_MIN	66.100	01/01/2000 00:00	Bourgerie, Richard - 8/10/2009 11:51:41
AG_ROFC	.150	01/01/2000 00:00	Bailey, Kathleen - 10/17/2008 20:06:00
AG_SIGMA	.200	01/01/2000 00:00	Bailey, Kathleen - 2/9/2009 11:07:21
DEPLOYMENT_DESIG	3.000	01/01/2000 00:00	Bourgerie, Richard - 8/12/2013 15:42:14
AG_MANUAL_ADJUSTMEN	.000	05/28/2008 16:21	Bailey, Kathleen - 6/3/2010 15:28:12
MEAN_AG_WL_OFFSET	70.020	05/28/2008 08:06	Bailey, Kathleen - 6/3/2010 15:41:39

Station To Reach Statement

The Station To Reach Statement is a guide to locate the station equipment (DCP Enclosure/Sensors) and the Low Steel location identified by the PORTS Partner. Furthermore, the statement shall document the sensor location relative to the center of the channel. Navigational lights can be used as a reference to describe the Low Steel location on the bridge. Bridge columns can also be used to reference the station and the center channel.

Sample *To Reach* Statement for an Air Gap station:

Travelling Eastbound 676 (New Jersey bound), the station is located on the south side of the bridge on a catwalk underneath commuter train tracks at bridge column marker W61, east of the main channel, 141 m (462.6 ft) east of eastern red navigation light on the Ben Franklin Bridge. The Low Steel location is the base of the red navigational light found on the bridge.

The statement shall be documented in the first page of the eSite report in section *Station To Reach*.

After station configuration and data ingestion is confirmed, the next steps are to complete the Air Gap Checklist and then the Air Gap Notice Letter. Without the completion of the Air Gap Checklist and Notice Letter, a station is not considered fully operational and DMAT shall not enter the operational flag in the database.

Air Gap Notice Letter

To describe in detail how Air Gap measurements relate to low steel on the bridge and to communicate this information internally and to our partners, in 2019 CO-OPS instituted the creation of the Air Gap Notice Letter. This letter documents the agreed upon low steel

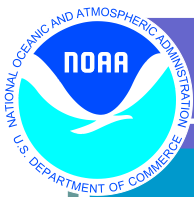

structure as well as how it is measured. It also documents the offset applied to the data. The letter is generated in coordination with the PORTS Manager and Staff Program Analyst. After several internal reviews, the letter is finalized and presented for CO-OPS Director for signature. The letter recipients include, but are not limited to: the PORTS funding partner, the bridge owner (if different from funding partner), relevant pilot associations, port authority personnel, local marine exchanges, USCG, USACE, NOAA CO-OPS personnel and NOAA OCS personnel for their signature acknowledging the Air Gap station installation, configuration, and operation. The letter is then sent to COET for archiving.

Air Gap Checklist

The Air Gap Checklist supports the generation of the Air Gap Letter. The checklist will compile all of the appropriate information in one central location so that the PORTS Manager and Staff Program Analyst can generate the Air Gap Notice Letter. FOD, ED, Staff are the responsible divisions for inputting the required information into the checklist. Each division is tasked with answering questions within the checklist and pass it on to the next division for completion. The failure to complete the checklist is an indication that the Air Gap station is not ready for full operational status. The checklist contains full instructions within on how and when to complete the checklist. Those involved with the population of the checklist should be familiar with the checklist requirements/instructions and make sure all relevant information regarding the Air Gap station is collected and archived prior to starting the checklist.

PORTS Manager is tasked with starting the checklist and passing it on to FOD. FOD will then pass it off to COET where the majority of the documentation is needed. In this section, the low steel information is documented as well the measurement of the low steel structure relative to the Air Gap sensor. Once the involved divisions have completed the checklist and the Branch Chiefs of those divisions have signed it, the checklist is then passed on to the PORTS Manager and Staff Program Analyst for final signage at which point COET will archive the checklist in the Station Archive folder.

7. Quality Assurance/Control

Proper configuration and operation of air gap systems requires close coordination between DMAT and COET. This is because of the data analysis and calculations involved in computing the AG_CAL_OFFSET. While COET computes the initial AG_CAL_OFFSET, it is DMAT's responsibility to verify this calculation. If an error or discrepancy is found, COET and DMAT must work together to correct the error.

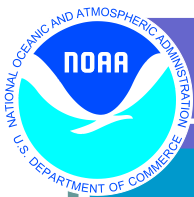

DMAT has the responsibility for turning dissemination on after the Air Gap Checklist and Notice Letter are signed.

8. Management/Responsibility

COET's responsibilities throughout the air gap acceptance process are to ensure that the database is correctly configured, that data is being ingested properly, the SENSOR_OFFSET is entered, and that AG_LS_OFFSET and AG_CAL_OFFSET are calculated and verified.

COET is also responsible for maintaining this SOP.

DMAT's responsibilities include verifying the AG_CAL_OFFSET calculation made by COET and entering station parameters AG_MAX, AG_MIN, AG_ROFC, AG_SIGMA and MEAN_AG_WL_OFFSET.

The PORTS Manager, Task Representative, and PORTS Partners are responsible for identifying the agreed upon Low Steel structure and the location of the Low Steel structure on the bridge. The PORTS Manager and Task Representative are responsible for communicating (email) this information to COET to properly configure the database and to archive the correct Low Steel location and elevation.

If any discrepancies with the data occur after installation, notify COET of your findings. For a contract installation you will need to notify the Task Representative, and for an FOD install you will need to notify the field operations Team Lead.

If you are having problems or have general questions regarding the data analysis, seek assistance from either the CO-OPS senior scientist or DMAT.

Figure 4: WaterLog Sensor Elevation Drawing

Air Gap Elevation Drawing

STATION ID, STATION NAME, DATE (DD/MM/YYYY)

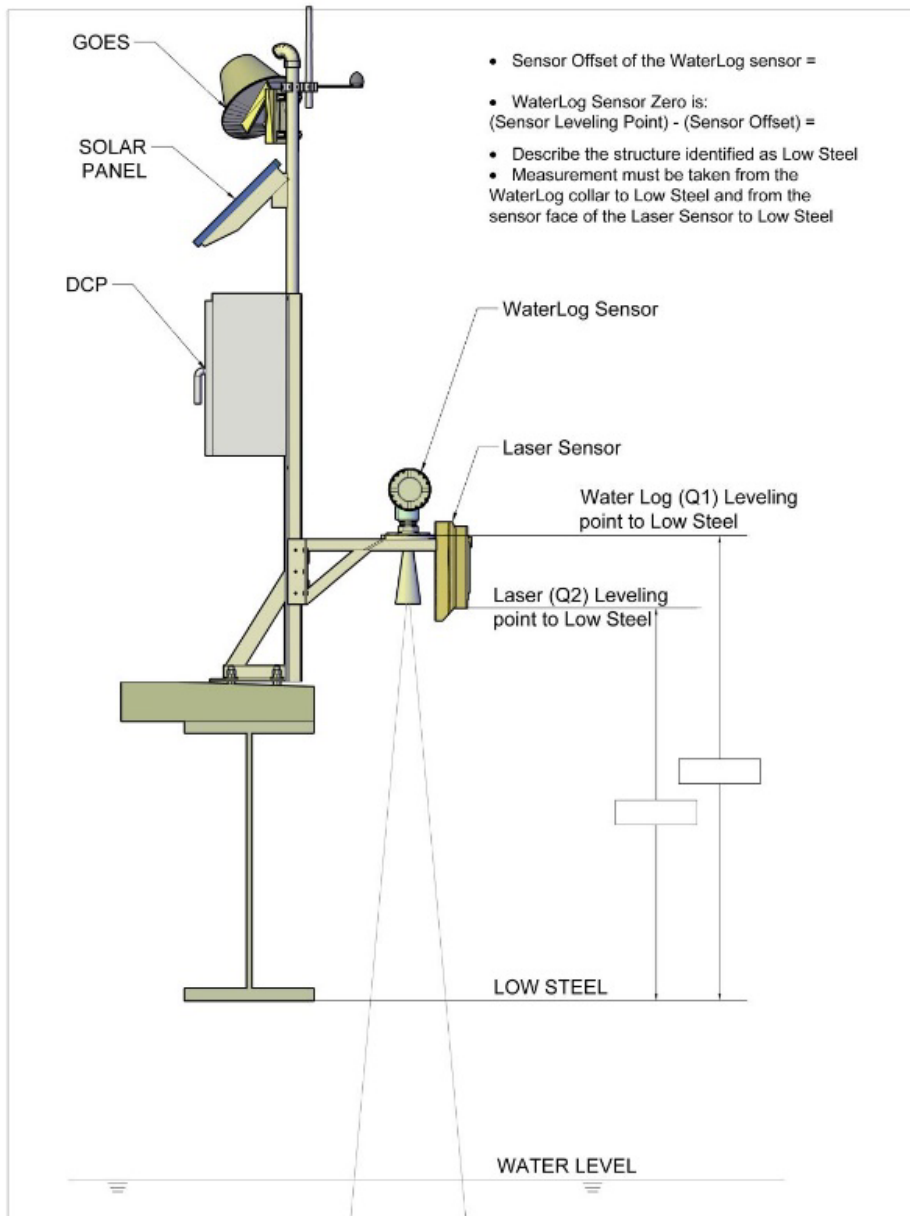

The elevation drawing is not drawn to scale. Its sole purpose is to display a representative drawing providing sensor to low steel relationships. For precise drawings of the station and bridge, consult the Design and Development Engineering Team or Task Representative. All measurements are in metric units.

Figure 5: Miros Sensor Elevation Drawing

Air Gap Elevation Drawing

STATION ID, STATION NAME, DATE (DD/MM/YYYY)

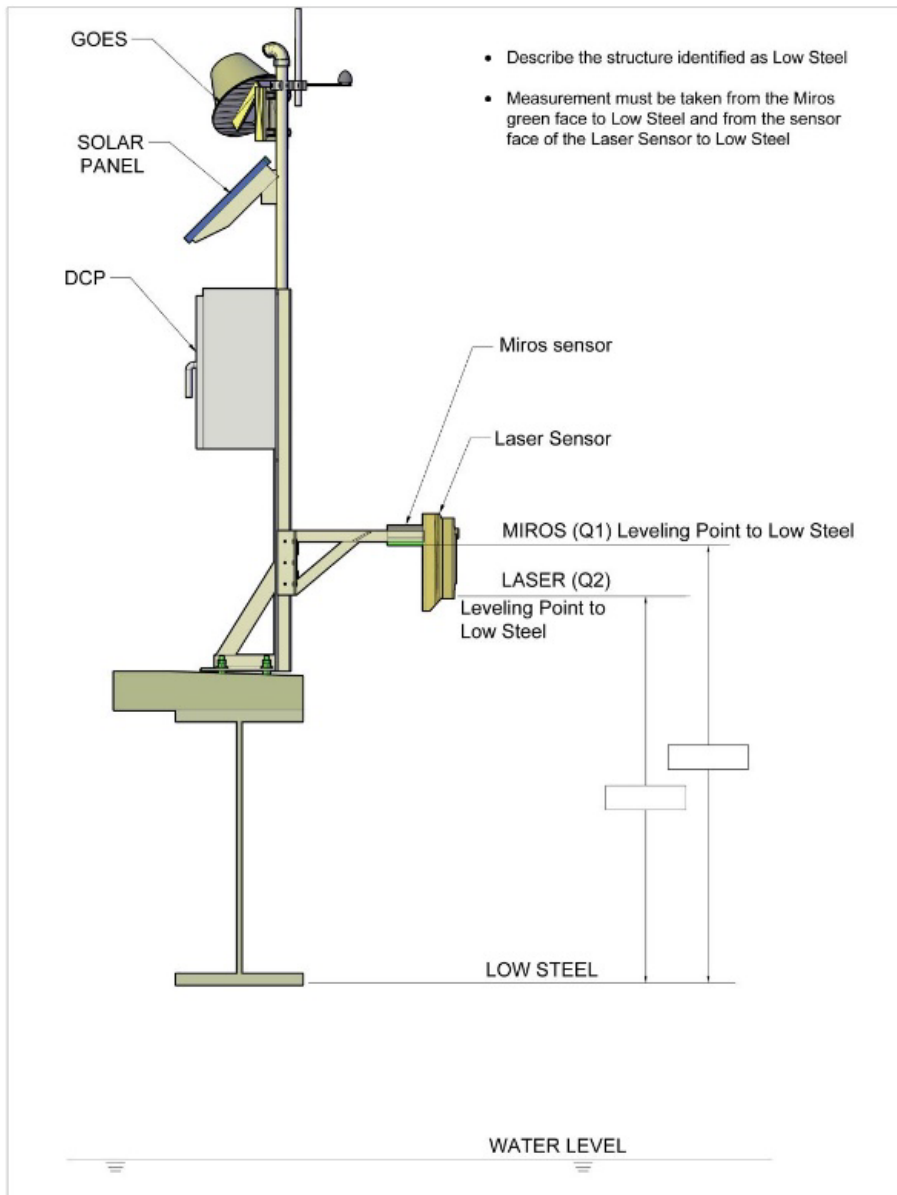

The elevation drawing is not drawn to scale. Its sole purpose is to display a representative drawing providing sensor to low steel relationships. For precise drawings of the station and bridge, consult the Design and Development Engineering Team or Task Representative. All measurements are in metric units.