



# Xpert Data Logger

---

---

## Operations and Maintenance Manual

---

---

Part No. 8800-1127

Rev 2.10

June 11, 2010

Sutron Corporation

22400 Davis Dr

Sterling, Virginia 20164

TEL: (703) 406-2800

FAX: (703) 406-2801







WEB: <http://www.sutron.com/>



















































# Table of Contents

<b>CHAPTER 1: INTRODUCTION .....</b>	<b>1</b>
FEATURES .....	2
Key Features .....	2
Features .....	2
HIGHLIGHTS .....	3
EzSetup and Graphical Setup – The Key to Flexibility .....	3
I/O Modules – The Key to Expansion .....	3
DLLs – The Key to Modularity .....	3
PRODUCT DESCRIPTION .....	4
Models .....	5
<b>CHAPTER 2: GETTING STARTED .....</b>	<b>7</b>
UNPACKING .....	8
Standard Items .....	8
Common Optional Items .....	8
Other Optional Items .....	8
INITIAL CHECKOUT .....	9
Powering Up .....	9
Adjust the Contrast (optional) .....	9
Verify Touchscreen and Display Work .....	9
Verify XTerm Works .....	9
Verify I/O Modules Work .....	9
OPTIONAL SLL LIBRARIES .....	10
PREPARING FOR SETUP .....	13
Analyze the System .....	13
Choosing the Right Block .....	13
<b>CHAPTER 3: OPERATING THE XPERT .....</b>	<b>15</b>
LOGGING IN .....	16
User Access .....	16
Tab Overview .....	16
MAIN TAB .....	17
Date/Time .....	17
Station Name .....	18
Station Status .....	18
Contrast .....	18
Battery Voltage .....	19
Logout .....	19
SETUP TAB .....	20
Tree Overview .....	20
Coms .....	21
COM Port Setup Menu .....	22
Coms Configuration Settings .....	24
EzSetup Measurements .....	31
Measurement Schedules .....	32
Sensor Configuration .....	33
Graphical Setup .....	37
I/O Modules .....	37
Log Files .....	38
Log Directory .....	39
Sizing Logs .....	39
Log Properties .....	39
Satlink .....	40
Satlink Dialog .....	40

Self-Timed Dialog .....	41
Append Lat/Lon .....	44
Self-Timed Test .....	45
Random Test .....	46
Satlink Status .....	47
Self-test .....	48
Setup File .....	49
New .....	49
Open .....	49
Save As .....	49
Append .....	50
Users .....	50
SENSORS TAB .....	52
DATA TAB .....	54
LOG TAB .....	58
Column Labels .....	58
Time .....	58
Sensor .....	58
Data .....	58
Q .....	58
Units .....	59
Date .....	59
Selecting Log File .....	59
Navigating the Log .....	59
+Day, -Day .....	59
Find .....	59
Clearing the Log .....	59
Export .....	59
STATUS TAB .....	61
USING PCMCIA ATA FLASH CARDS .....	63
Expand Log File Capabilites .....	63
Upload/Download Setups .....	64
Download Log Files .....	64
<b>CHAPTER 4: GRAPHICAL SETUP DIAGRAMS .....</b>	<b>65</b>
OVERVIEW .....	66
AN EXAMPLE GRAPHICAL SETUP .....	67
Block Categories .....	67
Block Inputs and Outputs .....	68
Block Connectability .....	68
Block Properties .....	68
CREATING A NEW SETUP DIAGRAM .....	70
Adding a Sensor Using the Wizard .....	70
Adding Additional Blocks .....	71
Changing Block Properties .....	73
MODIFYING A GRAPHICAL SETUP .....	76
Wiring and Unwiring .....	76
Deleting a Block .....	78
Deleting Multiple Blocks .....	79
Insert A Block .....	79
<b>CHAPTER 5: EXAMPLE SETUPS .....</b>	<b>81</b>
EZSETUP STREAM GAUGING STATION .....	82
GRAPHICAL SETUP TO COMPUTE DAILY MIN/MAX .....	87
<b>CHAPTER 6: OPERATION WITH A PC RUNNING XTERM .....</b>	<b>89</b>
INTRODUCTION .....	90
Installing XTerm .....	90

SSP Settings .....	92
Preparing the Xpert to work with XTerm.....	93
Operating XTerm.....	93
File Transfer .....	95
Process List Folder.....	96
Set Clock .....	97
Connect.....	98
Upgrade .....	98
Web Server.....	98
Auto Update .....	98
Configuring the PC modem for use with Xterm.....	98
Status and Rx, Tx, Xp, Err indicators .....	99
Special Command Line Options.....	101
<b>CHAPTER 7: INSTALLATION.....</b>	<b>105</b>
STEPS TO INSTALL AN XPERT .....	106
USING COM PORTS.....	109
Overview .....	109
Pin-out information .....	109
Jumper Settings .....	110
Maximum Current Draw from Pin 9 .....	111
Xpert Com 2 - 4 .....	111
Xpert com 5 - 9 (Optional Quad Serial board) .....	111
OPTIONAL RS-485 COM PORT.....	111
Overview.....	111
Pinouts .....	112
Switched power settings.....	112
Maximum current draw from constant and switched power pins.....	112
<b>CHAPTER 8: MAINTENANCE AND TROUBLESHOOTING .....</b>	<b>113</b>
COMMON MAINTENANCE AND TROUBLESHOOTING.....	114
Calibrate the Touchscreen .....	114
Skip the autoexec.bat.....	114
Xterm has a White screen or Black Screen.....	114
Adjust the contrast.....	115
Replace the Internal Battery every 5 years .....	115
Cleaning Instructions.....	115
Fuses.....	116
<b>APPENDIX A: SETUP BLOCKS.....</b>	<b>117</b>
INTRODUCTION.....	118
SENSOR BLOCKS .....	119
 Air Temperature Sensor (AirTemp).....	119
 Air Temperature/Relative Humidity (AT/RH) .....	121
Analog (ADC) .....	122
 Barometric Pressure (BP) .....	128
 BEI Absolute Encoder (BEIEnc) .....	129
 Binary Input (BinIn) .....	130
 Binary Input – All Channels (BinInAllChan) .....	132

	Bridge Resistance (Bridge).....	134
	CapRain (CapRain).....	135
	Constant (ConstIn).....	137
	Counter (Counter).....	138
	CS107 Temperature Sensor (CS107Temp).....	140
	Frequency (Freq).....	142
	Fuel Moisture (FM).....	144
	GetTag.....	145
	GillWind (Gill Wind Sensor).....	146
	Internal Battery (IntBat).....	148
	Log Input.....	149
	MRL 700 Radar Sensor (MRL700).....	150
	Platinum RTD (PlatRTD).....	152
	Quadrature Shaft Encoder.....	154
	R.M. Young Wind Sensor (RMYoung).....	155
	SDI-12.....	157
	SDI AquaTrak (SDIAqua).....	158
	SE8500 (SE8500).....	159
	Send Current Time (SendTime).....	160
	Soil Moisture (SoilM).....	161
	Solar Radiation (SolRad).....	163
	Submersible Pressure Transducer (SubPres).....	165
	Tipping Bucket Sensor (Precip).....	166
	Volt Meter (VoltMeter).....	168
	PROCESSING BLOCKS.....	170
	Alarm.....	170
	Accumulator (Accum).....	172
	Average (Average).....	173

	Bool (Boolean).....	175
	Dew Point (DewPt).....	176
	DQAP (Quality-Controlled Average) .....	177
	Interpolate (Interpolate).....	179
	Georgia Pacific Sampler (GPSmpl).....	181
	Measure (Measure) .....	182
	Minimum/Maximum (MinMax) .....	183
	Moving Average (MovingAverage) .....	184
	Polynomial (Poly).....	185
	PtCtrl (Point Control) .....	186
	Set Point Control (SetPoint) .....	188
	Solar Radiation Accumulator (SRAcc).....	189
	Vector Average (VectAvg).....	191
	XY Function (XYFunct).....	193
	LOGGING BLOCKS .....	194
	Log.....	194
	TELEMETRY BLOCKS.....	196
	Coms Tag.....	196
	Random Group (RndGroup) .....	197
	Random Parameter (Random) .....	199
	Self-Timed Parameter (SelfTimed).....	200
	OUTPUT BLOCKS .....	205
	Binary Out (BinOut) .....	205
	Pulse Out (PulseOut).....	206
	Send Tag .....	207
	MISCELLANEOUS BLOCKS .....	208
	Display (Display).....	208
	Field Variable (FieldVar).....	209
	<b>APPENDIX B: UPDATING THE FIRMWARE.....</b>	<b>212</b>

UPDATING THE FIRMWARE .....	213
Using XTerm Upgrade .....	213
Customizing an XTerm Upgrade .....	213
Manual Component Upgrade.....	215
Upgrade the Boot Loader .....	215
Initialize the Flash File System .....	215
Update the Kernel and Extension.....	216
Update the Application .....	216
<b>APPENDIX C: I/O MODULES .....</b>	<b>219</b>
ANALOG I/O MODULE – 8080-0003 .....	220
Features.....	220
Specifications.....	221
Operational States.....	222
Running.....	222
Stopped .....	222
Inputs/Outputs .....	222
Inputs .....	222
Outputs.....	222
Analog Measurements .....	222
Accuracy.....	223
Example Configurations Using the Analog I/O Module .....	224
DIGITAL I/O MODULE .....	225
Inputs .....	226
Outputs .....	227
<b>APPENDIX D: SPECIFICATIONS.....</b>	<b>228</b>
Basic Unit with Display – 8080-0000-1 .....	229
Basic Unit without Display – 8080-0001-1 .....	229
I <sup>2</sup> C Modules .....	229
RS232 Modules .....	229
Speech Modem .....	229
LOS Radio .....	230
Satlink Transmitter.....	230
<b>APPENDIX E: SOFTWARE DEVELOPMENT KIT (SDK).....</b>	<b>231</b>
OVERVIEW .....	232
<b>APPENDIX F: CREATING CUSTOM VOICE FILES .....</b>	<b>233</b>
OVERVIEW .....	234
<b>APPENDIX G: AUTOEXEC.BAT AND REMOTE.EXE .....</b>	<b>235</b>
AUTOEXEC.BAT .....	236
REMOTE.EXE .....	237
ABOUT Command Example .....	245
Get Command Example .....	245
INFO command Example .....	246
MAIL Command Example.....	247
MEASURE/SHOW Command Example .....	247
PASSTHRU Command Example.....	248
RECORDING Command Example.....	248
SET Command Example.....	248
SHUTDOWN Command Example .....	248
STARTUP Command Example .....	248
STATION Command Example.....	248
STATUS Command Example .....	248
UPGRADE Command Example .....	248
YMODEM Command Example.....	249

<b>APPENDIX H: DIMENSIONS .....</b>	<b>250</b>
XPERT DATA LOGGER .....	251
I/O MODULES .....	252
XPERT MODEM.....	253



# **Chapter 1: Introduction**

# FEATURES

---

Sutron's Xpert is designed to be the heart of a wide range of remote monitoring and control systems. The Xpert is a highly modular design that is scalable to handle simple to complex requirements.

## Key Features

- Intuitive, EzSetup and a graphical block-oriented setup.
- Unlimited expansion with I/O Modules.
- Software extensibility with DLL libraries.

## Features

- PCMCIA module slot for memory expansion.
- Multiple, independent log files. Changes to setup do not affect logged data.
- Modular design – you build the logger from modules offered by Sutron.
- Expandable – additional modules can be added as needed.
- Scalable – handles simple as well as complex sites.
- Low power consumption – sleep modes with low quiescent power, low operating power.
- Battery operated – each module operates off of 9.5 to 16 VDC.
- Wide temperature operation – -40 to +60C.
- High reliability and robust – no fuses, fault tolerant, lightning protection.
- Multiple telemetry – can add telephone, LOS Radio, GOES, METEOSAT telemetry.
- Plug-n-play ease of setup – the system is setup with ease. Install a new module, and the system automatically detects it and allows it to be configured for operation.
- Flexible measuring and recording – The setup allows separate measuring schedules for data as well as individual recording intervals.
- Open design – the system will operate with sensors and modules manufactured by others.
- Takes measurements from low cost sensors.
- High-speed data transfers – data downloads to PC at 115k baud.
- Time accuracy of two seconds per day over full temperature range.

## HIGHLIGHTS

### EzSetup and Graphical Setup – The Key to Flexibility

A unique part of the design is the ability to use the EzSetup and/or the graphical block-oriented setup. Many simple measurements are quickly setup using EzSetup, for even more flexibility the graphical setup blocks of various types are connected together to graphically represent data flow from all sensors, with data flowing from left to right. An example EzSetup is shown below on the left and a graphical setup is shown below on the right.

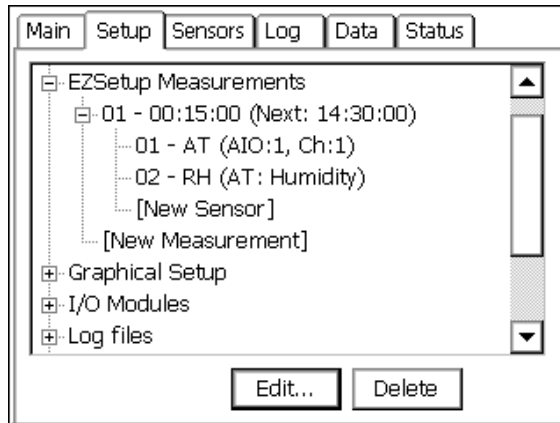

EzSetup Measurements

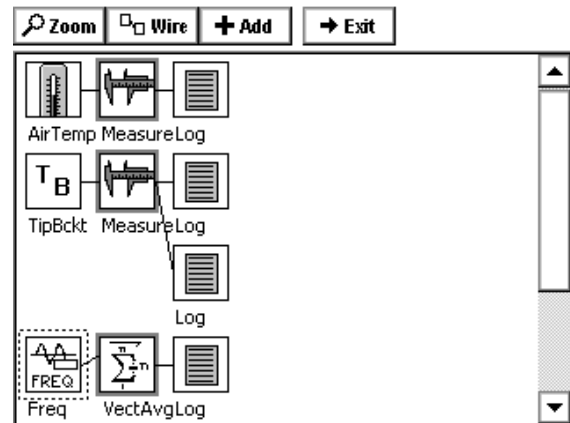

Graphical Setup

### I/O Modules – The Key to Expansion

The Xpert epitomizes the concept of expandability. By itself, the Xpert functions as a highly capable SDI-12 v1.3 compliant logger. To add a sensor with an analog or digital output, simply connect a Sutron I/O module in through the unit's I<sup>2</sup>C port. Need to add more sensors than one module will support? Simply stack additional modules onto the first. The Xpert supports a nearly unlimited number of analog and digital I/O modules, so running out of I/O is never an issue.

### DLLs – The Key to Modularity

The Xpert software is modular and utilizes Windows DLLs (Dynamic Linked Libraries). DLLs are additional software components that can be added to the system at any time without having to update the main software.

This makes adding a new feature to the Xpert that was not available when the unit was purchased easy - simply download the new DLL from the Sutron web page, and send it across to the Xpert. This might be done, for example, to add support for a new sensor, or to add some newly released communication capability to the unit. Some customers can even create their own DLLs using Microsoft Visual C++ and a Software Development Kit (SDK) provided by Sutron.

## PRODUCT DESCRIPTION

The Xpert data acquisition platform is based on a 486 microprocessor, the Windows CE operated system, and a touch-sensitive graphical display (optional). The Xpert comes in two models: one with a touch screen and one without a touch screen. Sensors are added to the system via the SDI-12 port or via I/O modules that plug into the I<sup>2</sup>C port. For data retrieval, the Xpert comes with up to four serial ports for connection to satellite, modem, a PC, the Internet, etc. In addition, every unit comes with a minimum of two megabytes of RAM for data storage. All inputs to the systems can be found at the bottom side of the unit, as shown below. The Xpert requires power from an external battery of 9.5-16 VDC.

All the functionality in the Xpert can be accessed through the touch screen of the device. The screen can be activated either with the special stylus that came with the system or with a finger. All the operations necessary to operate the unit can be done via the graphical interface on the touch screen. For units without a touch screen, the windows based program Xterm.exe provides the necessary screens for operation.

*Xpert (with Display) and Analog and Digital I/O modules*

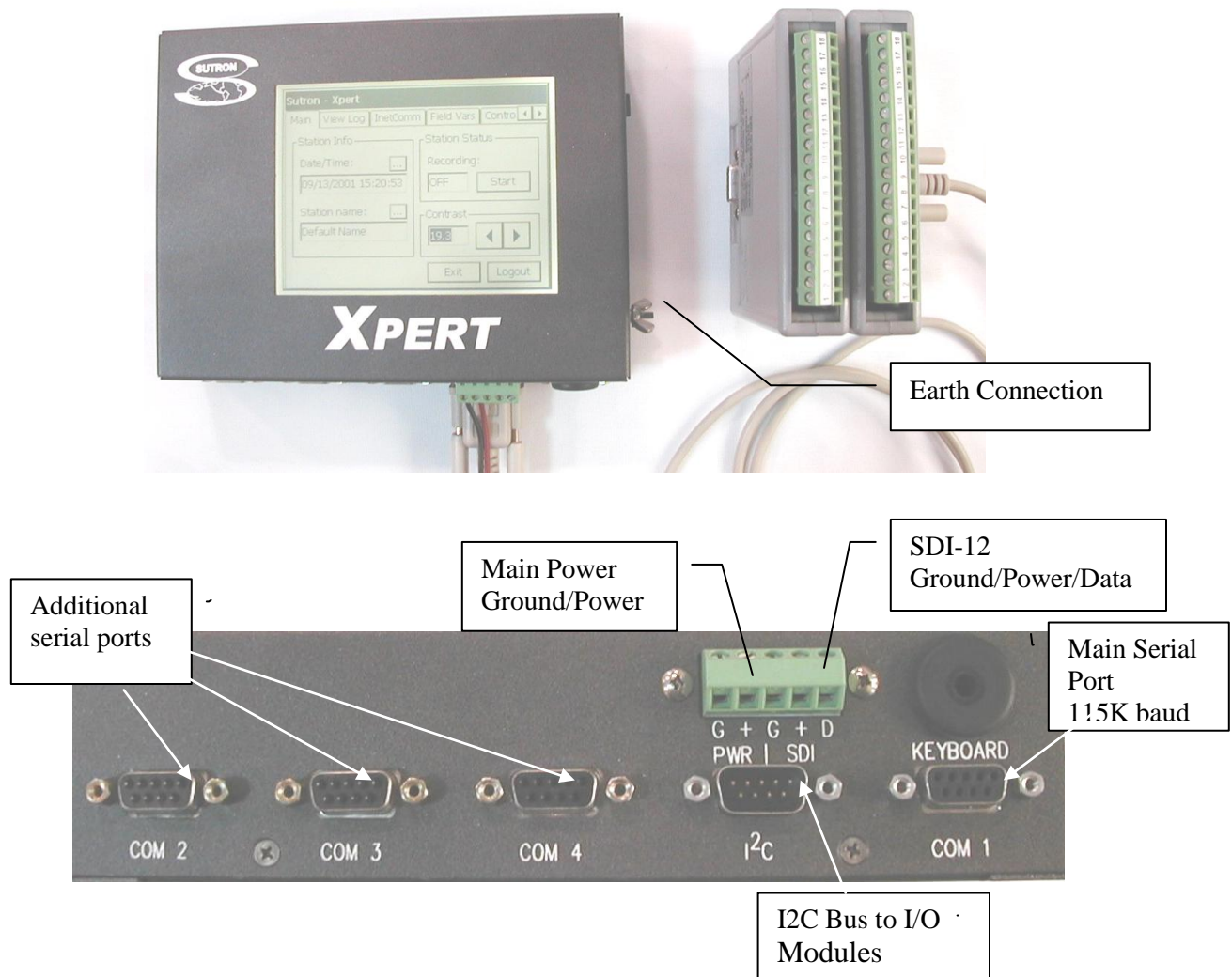

## Models

The Xpert comes in several different models. The available models include:

- 8080-0000-1 Xpert with Display and Backlight
- 8080-0000-2 Xpert with Display and Backlight and 8 Serial ports
- 8080-0001-1 Xpert without Display

In addition, the following are available as add-ons to the system.

### Xpert Telemetry modules

- 8080-0005-1 Speech modem
- SATLINK-G312-1 Satellite Transmitter

### RS-485 COM PORT BOARD

- 6461-1251-1 Xpert,RS-485

### Xpert I/O modules

- 8080-0002-1 Xpert, Digital I/O, 8 Channels
- 8080-0002-4 Xpert, Digital I/O, 8 Channels with Surge Protection and 24" Cable
- 8080-0002-2 Xpert, Digital I/O, 1 Channel High Speed
- 8080-0003-1 Xpert, Precision Analog I/O, 6 Channels
- 8080-0003-3 Xpert, Precision Analog I/O, 6 Channels with Surge Protection and 24" Cable

### PCMCIA Memory Expansion

- 8080-0011-32 PCMCIA, 32 MB ATA Flash card, extended temperature range (-40 to +85C)

### Termination boards

- 6461-1239-1 RS232 Surge Protection
- 6461-1240-1 Phone Surge Protection
- 6461-1241-1 SDI Surge Protection
- 6461-1242-1 Power Protection



# **Chapter 2: Getting Started**

## UNPACKING

---

Carefully unpack the Xpert and other components that came with the system. Note that some items come standard with every Xpert while other items are optional.

### Standard Items

The following items come with every Xpert that is shipped:

- One Xpert.
- One stylus for use with the touch screen (only with models that have a touch screen).
- One 3.5" PC Utilities disk.
- One manual.
- One DB9 M-F serial cable.

### Common Optional Items

The next items – sold separately, either because they can be shared between systems or because not all installations require them – are often also included:

- A DB9 M-F serial cable for I/O Modules.
- One or more Analog I/O modules.
- One or more Digital I/O modules.
- One or more termination boards.
- System enclosure box.
- Lead acid battery.
- Solar panel regulator.
- PCMCIA ATA flash disk card.

### Other Optional Items

One or more of the following might also be included:

- Analog, digital or SDI-12 sensors.
- Modem, Line-of-Site Radio or Satellite transmitter.
- Antenna.

# INITIAL CHECKOUT

---

## Powering Up

To start the Xpert, connect power (9.5 to 16 VDC) to the G and + power connections on the left side of the terminal strip (labeled PWR). When power is applied, the Xpert will first display a startup screen and then, if configured to do so, display the login screen. Note: do not touch the screen during power up as this may cause the Xpert to run one of its special power-up routines.

## Adjust the Contrast (optional)

On the Xpert, if the login screen is not readable the contrast may need adjustment. Try pressing the display in the upper right corner to lighten the display or press in the lower right corner to darken it. Wait at least 2 seconds each time you press the display for the adjustment to take effect. If pressing the display has no effect, the application program is probably not running. Refer to the troubleshooting section for help to diagnose the problem.

## Verify Touchscreen and Display Work

To verify the touchscreen and display work, press the Setup Access button on the login screen. Then press the button labeled  next to the station name. Use the stylus, enter a name for the station and press OK. If the Xpert does not respond properly to the stylus, the touchscreen may need calibration. Refer to the troubleshooting section for help to recalibrate the touchscreen.

## Verify XTerm Works

XTerm is a program that connects your PC to the Xpert. Using XTerm you will be able to setup and test an Xpert or Xpert without display. See Chapter 6 for the details on how to install and run XTerm.

## Verify I/O Modules Work

If you purchased separate I/O modules with the Xpert, connect the I/O modules together, and then using a 9-pin cable, connect them to the I<sup>2</sup>C port on the Xpert. You can connect the cable to either side of the I/O modules. Once the modules have been connected, use the stylus (or PC mouse if using XTerm) to select the tab labeled *Setup*. If you don't see it as one of the tabs, use the scroll buttons to the right of the tabs to bring it into view. Now press the + in front of the I/O Module branch. You will now see a list of the modules you have connected to the system. If you do not see the + in front of I/O Modules, the system was not able to detect any I/O modules. Check your cable to the I/O modules. Make sure you are connected to the I<sup>2</sup>C port. Refer to the troubleshooting section for help if you cannot get the system to find the I/O modules.

The initial checkout of the Xpert is complete.

## OPTIONAL SLL LIBRARIES

---

Sutron has written several custom sll's for various customers. These sll's are provided in all upgrades for convenience. While most of these sll's are specific to certain sensors, special processing, etc., other customers may find a use for them. Listed below are all the extra-SLLs that are provided in a standard upgrade zip file, along with a short description of their purpose. If you find that one of these sll's may be of some use to your application, and you want more information, please contact Customer Service.

NOTE: In some of these sll's, a serial interface is needed. In most cases, the blocks that are created, or setup tab entries that are made, will need to have full control of the com port. This is accomplished by leaving the com port set to "NONE" in the coms branch under the setup tab. Refer to the specific documentation for the sll to see if the com port is to be defined in coms or not.

Aanderaa.sll	The purpose of this SLL is to receive data from an Aanderaa logger, but may also be used to parse any space or comma separated numeric data using an RS-232 com port.
AirGap.sll	The purpose of this SLL is to allow users to connect a MIROS Air Gap water level sensor to one of the COM ports.
AlohaHazmat.sll	Formats and outputs messages specific to the Aloha Hazmat PC desktop software via com port. Supports Aloha weather station.
ASWell.sll	This SLL implements a custom processing block to support Alamosa Salvage Well control.
ATDisplay.sll	The purpose of this SLL is to allow users to display information from an Xpert/Xlite LOG file on an Adaptive Technologies display device. Adaptive Technologies offers a variety of indoor and outdoor displays that can be used to make information in an Xpert easily accessible to the public.
AWOS.sll	This SLL implements custom processing blocks and reporting mechanisms to support AWOS weather stations.
CoOp.sll	This SLL implements custom sensor and processing blocks to support CO-OP weather stations. Sensors include OTT Rain gauge and Stevens Soil moisture probe. Processing block for the Geonor Rain gauge is also included.
DGH.sll	The purpose of this SLL is to connect any DGH output module, typically a 4-20mA or 0-5V, to a com port. The DGH module simply needs to respond to the following output string: \$1AO+0yyyy.yy followed by a CR. Refer to App note 33 for details on use of this block.

Evapotran.sll	The purpose of this SLL is to add an Output block to weather stations that will calculate daily potential evapotranspiration (ET0)
GPRS232.sll	This SLL provides a general purpose RS-232 communications block, intended to enable measurement of a variety of RS-232 sensors.
IMD.sll	This SLL implements custom reporting functionality required by IMD.
IECModbus.sll	This SLL extends the capabilities of the modbus sll to work with a device built by Applied Systems Engineering to interface to an IEC-104 network.
LCRAPLCDriver.sll	The purpose of this SLL is to connect a serial input PLC to one of the COM ports. The PLC is used to provide remote output of the headwater and tailwater levels in reservoirs
LCRASerialDisplay.sll	The purpose of this SLL is to connect a two-line Adaptive Alpha™ display to one of the COM ports. The purpose of the display is to provide remote output of the headwater and tailwater levels in reservoirs.
ManualEntry.sll	This SLL adds a block that allows the user to enter observed data measurements manually.
Modbus.sll	The purpose of this SLL is to add the ability to communicate via modbus to the Xpert/9210. For more information, see the document “Xpert Modbus SLL User Manual”, available under separate cover.
NIFC.sll	The purpose of this SLL is to provide the necessary blocks to connect sensors used in Fire Weather applications.
NOS.sll	This SLL implements a reporting mechanism for NOS stations using the user login and a data file to determine the report contents. In addition, this sll adds average and measure blocks that allow data time-stamps to be centered on the interval.
Pflow.sll	This SLL implements custom pump flow rate and duration calculations.
PPSaver.sll	This SLL implements custom power-saving measurement and communication algorithms for Poland Power project.
QFE.sll	This SLL adds a sensor block used to calculate standard atmosphere based on elevation.
RDI.sll	This SLL Implements RDI protocol.
Relay.sll	This SLL contains a block intended to control a relay. The block will set a digital output for a specified time duration, and

	then clear the output.
RS485SDI.sll	This SLL enables SDI over 9210 RS485 com port, com 4.
SR50.sll	This SLL enables measurement of SR50 ultrasonic height guage.
SRP.sll	This SLL works with the 9210 only, prompting the user to download data after inserting a PCMCIA storage card.
TerminalServer.sll	This SLL adds commands to the remote command line interface based on the user login.
VibratingWire.sll	The purpose of this SLL is to allow users to connect a Canary Systems VW DSP serial interface to one of the COM ports on a Sutron Xpert or XLite (Model 9210) data logger. The VW DSP can be used by itself to measure temperature and pressure from two vibrating wire sensors (e.g. those made by Geocon). The VW DSP can also be wired to one or more Canary Systems MiniMuxes, providing the capability to measure from additional sensors in increments of 16 or 32 per MiniMux.
VWireMux.sll	The purpose of this SLL is to allow user to log multiple pressure transducer and optional thermistor readings by using a Canary Systems MiniMux™ digital switch.

# PREPARING FOR SETUP

---

This section discusses various issues important to know before setting up the Xpert.

## Analyze the System

Chapters 3 and 4 describe all the elements that go into setting up the Xpert. Before jumping in to setting up the unit, it's useful to think about the nature of the problem the Xpert is being used to solve. The following questions can help guide that thinking:

- What data needs to be collected?
- What sensors will give this data?
- What is the raw output of these sensors, DC voltage, AC voltage, frequency, Serial, etc.?
- Can the built-in I/O handle all of these sensors, or are additional modules needed?
- How often should this data be collected?
- What processing is needed to convert this raw data into a meaningful value? Is there already a block defined to do this processing or is a generic input needed?
- Where does the data need to go once it is processed, to a Satlink, a modem, a LOS radio, a serial device (PC, display, printer) or just to a log?

Chapter 5 describes several example setups that can help get you started in configuring the Xpert. If you need more help, don't hesitate to call our Customer Service department. They've worked with many data collection and reporting scenarios, and can help you set up your system just as you need.

## Choosing the Right Block

As Chapters 3, 4 and 5 will reveal, the Xpert setup is based on "blocks" that perform a specific function on data collected from a sensor, or from another block. The Xpert's *Graphical Setup* provides an interface to connect and configure these blocks. The Xpert's *EzSetup* interface also uses blocks, though they are hidden from the user's view.

Here's a simple map of sensor types to block types:

Sensor Type	Sensor Block
DC voltage output	VoltMeter or ADC
Resistance	ADC
Frequency output	Counter or Frequency
SDI-12 output	SDI-12
RS-232/RS485 output	RS232 (GPRS232.sll) or Basic Sensor

See Appendix A for a listing of all the different types of blocks available in the system.

The most common measurement type is an analog measurement, i.e., either a voltage or resistance. Many analog sensors simply specify a +5 V excitation voltage and provide a slope and offset. The ADC block provides all the properties needed to make this measurement.

For the most accurate analog reading, use the ADC block's *Double Volts* option, and multiply the given slope by 5. *Double Volts* will always return a ratio of REF / reading,

meaning it will return a value between 0 and 1, since the slope for a +5 REF assumes an output of 0 – 5. Multiplying the given slope by 5 will return the correctly scaled value. Using *Double Volts* will require 2 analog channels. If the system is running low on analog inputs, the *Voltage* reading could be used, if you multiply the given slope by 2 (since Vref is 2.5).

What if you don't see a block that appears to do what you need? Starting with version 2.2, the Xpert supports Xpert Basic, a programming language with which you can write your own blocks, and other custom processing. Refer to the Xpert Basic Users Manual for more details.

# **Chapter 3: Operating the Xpert**

This chapter describes how to operate the Xpert using its graphical user interface (GUI). If the Xpert has a touch screen display, the GUI is available on the front of the Xpert. If the Xpert does not have a touch screen then a PC running XTerm must be used to get access to the GUI. See chapter 6 for instructions on how to install and run XTerm.

# LOGGING IN

---

## User Access

After connecting with Xterm, two choices of access are available – Retrieval and Setup. Each succeeding level provides all the privileges of the preceding level. Therefore, users logging in under Setup Access can retrieve data, but users logging in under Retrieval Access cannot access the system setup. Multiple usernames/passwords (accounts) are allowed for these levels. If no users are added for a particular level, then that level can be entered without a password.

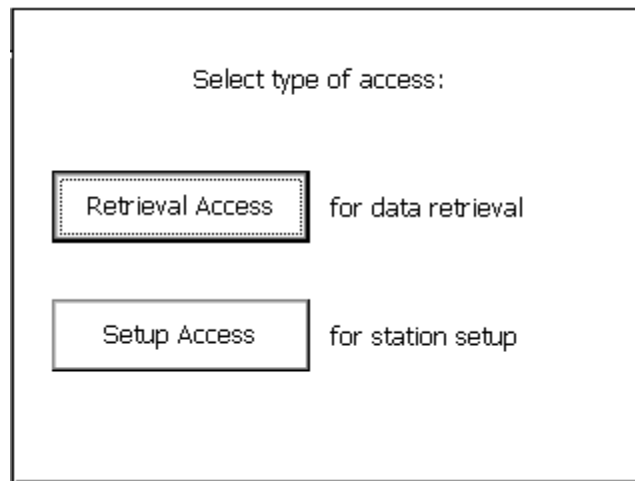

Logging into the unit causes a note to be sent to the system log, recording the username and time of the login. The user accounts are maintained on the *Setup* tab under *Users*. Access to this tab is available to the Setup group only.

Press the Logout button on the Main tab to logout. NOTE: If using Xterm, Logout does not close Xterm, it just logs you out of the system.

The contrast setting for the Xpert display can be changed from the login dialog (temperature extremes affect contrast considerably and can render the display unreadable without adjustment). Invisible “buttons” exist in the upper and lower right corners of the screen. Each button is about an inch or so square. Pressing the upper right button increases the contrast setting, while pressing the lower right button decreases the contrast setting.

## Tab Overview

To see all available tabs, login using the Setup Access button. Many tabs are available, clicking one of these tabs will bring it to the foreground for viewing. Of all the available tabs, the *SETUP* tab is used primarily to set the system up, the other tabs simply provide station status or details on collected data.

## MAIN TAB

---

After logging in, the display should look similar to the one shown below, with the *MAIN* tab in the foreground. The *MAIN* tab is where information about the station status is primarily displayed.

Across the top of the screen is a text label that identifies the platform. Under this label are a series of tabs like the tabs on file folders. These tabs are used to provide quick access to the different functions.

The screen image below reveals tabs for *Main*, *Setup*, *Sensors*, *Data*, *Log* and *Status*. The actual tabs displayed on a system depend on the DLLs installed in the system and the access mode selected at login.

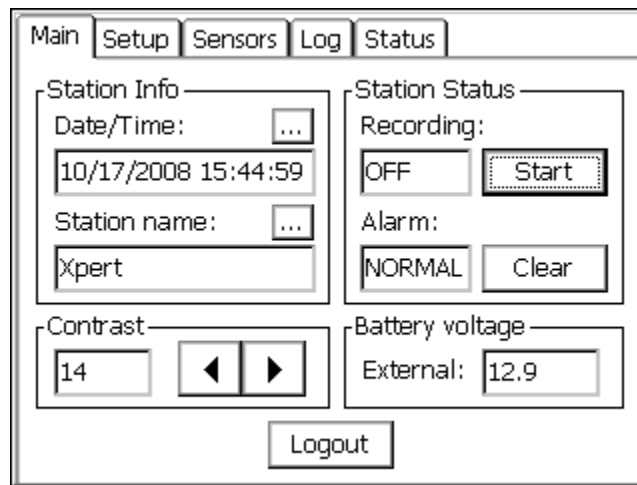

### Date/Time

Date and/or time are used to perform scheduled functions. The internal clock will keep time accurate to two seconds a day over the temperature range of -40 to +60 C. The date and time is maintained even after power is removed from the system by a lithium coin-cell battery.

NOTE: On Satlink systems, with self-timed transmissions enabled, the system will synchronize its clock to the Satlink periodically, maintaining higher clock accuracy.

To change the date or time, press the  button to bring up the Set Date/Time window shown below. Use the stylus or the << or >> buttons to move from one field to the next, and use the numbers in the virtual keypad to enter the new value. The values in the field can also be incremented or decremented via the + and - buttons.

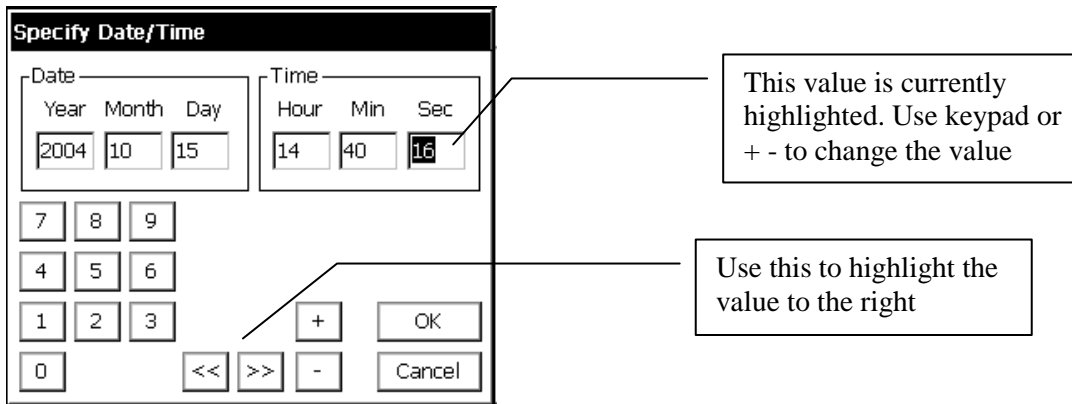

## Station Name

The station name is the general-purpose identifier for the station. It can be up to 16 alphanumeric characters. This name does not need to be the same as the GOES/METEOSAT identifier, but is used when connecting into a SSP system as the slave station name. When communicating to other stations, or a base station (PCBASE, XCONNECT), this name is case-sensitive, therefore it should be entered in UPPERCASE letters to avoid confusion.

NOTE: If the station name is changed, power must be cycled for SSP communications to use the new name. When the Xpert is started, it will try to load a setup file with the same name as the station name.

## Station Status

The Station Status box indicates both the recording and alarms states, and contains buttons to affect those states.

The recording status box indicates the current state of recording (i.e., whether measurements are being made and logged). This box also indicates whether transmissions are enabled when recording is on. When recording is off, the status box reads “OFF” and the button to its right is labeled *Start*. Pushing *Start* will start recording, changing the status box to read “ON” (or “ON+TX”, if transmissions have been enabled in the setup). The *Start* button then changes to read *Stop*.

The alarm status box indicates the current alarm state. The current alarm state may be NORMAL, ALARM, or ALERT. The Clear button is used to clear the current state (a clear during ALERT transissions the system to ALARM, while a clear during ALARM transissions the system to NORMAL). See *Coms* under *Setup* for more information.

## Contrast

The contrast setting for the Xpert touchscreen display can be adjusted using the “<” and “>” buttons. The “>” button increases the contrast while the “<” button decreases it.

Note: This contrast adjustment has no affect on the XTerm program, adjusting it from Xterm will effect the LCD though.

## Battery Voltage

The Battery Voltage status area displays the supply voltage. This value is measured and updated every 5 minutes.

The internal lithium clock battery should be replaced every 5 years. This battery is only used for preserving date and time when power is removed from the system. If on power up, the system detects that it has lost the date and time, it will set the date to 1/1/1984. No other operating parameters are preserved by this battery. See Common Maintenance and troubleshooting for information on changing the battery.

## Logout

Pressing *Logout* will re-display the login screen and turn off the display. You will need to touch the screen again to turn on the display.

If using Xterm, the connection to the unit is not shut down on a logout. Close XTerm by pressing the X in the upper right hand corner to ensure the remote system can go into it's lowest power mode.

## SETUP TAB

The setup tab allows for viewing and editing system settings. The items shown in the setup tab will vary depending on the configuration of the system and the version of the system software. Some standard entries are: *Graphical Setup*, *I/O Modules*, *Log Files*, *Self-test* and *Setup File*. Examples of entries that might also appear include: *Coms*, *EZSetup Measurements* and *Satlink*.

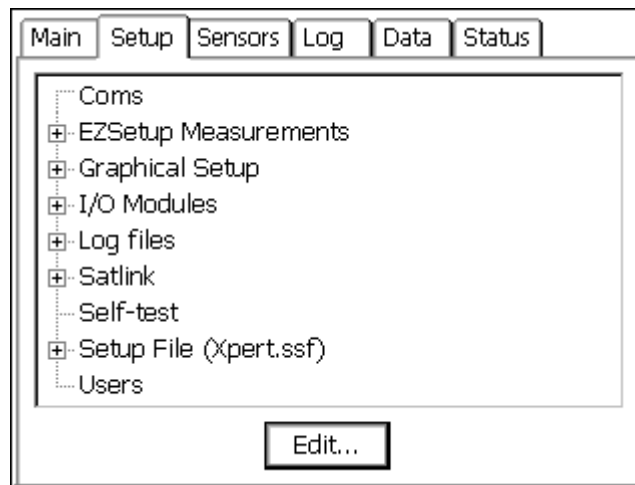

### Tree Overview

Items in the setup tab are displayed with branches that can be expanded or compressed by clicking the '+' or '-' next to the branch. This structure allows for displaying only as much information on the screen at one time as desired.

The following table gives a brief description of the purpose of each item. The sections following the table give more detail on each item.

<i>Tree Item</i>	<i>Description</i>
Basic	Used to compile and schedule basic programs. See the Xpert Basic SLL User's Manual for more information.
Coms	Used to configure SSP and Command Line communications (e.g., communications with Xconnect, PCBase, Xterm, Hyperterminal, etc.). This section is not used with most extra sll's that use com ports, unless the documentation for that sll says to use a specific connection in the Coms setup.  Note: See Chapter 7 for coms pinouts and jumper settings.
EZSetup Measurements	Used to define simple (single input) measurements. Sensor measurements defined here can be measured or averaged on a regular interval, have a slope and offset applied, be displayed on the front panel, be transmitted via Satlink or modem, and be used to identify alarm conditions.

Graphical Setup	Used to define both simple and complex measurements. Measurements can have one or more inputs cascading into one or more outputs. Special processing blocks can be used to implement complex calculations, including polynomial, interpolation table, f(x,y), and others. See the Processing section in Appendix A, for descriptions of all possible blocks.
I/O Modules	Used to view address and serial numbers of I/O modules connected to the system. The 9210 has three modules built into it, AIO1, DIO1 and DSP1. Note: If you connect any external I/O modules to the system, their module number MUST be set to 2 or higher.
Log Files	Used to view, and define new, log files.
Satlink	Used to configure a Sutron Satlink transmitter.
Self Test	Used primarily by the factory for verifying the unit meets specifications. Please note that external test harnesses and cables are required for all tests to pass.
Setup File	Used to manage setups. On power up, the setup file having the same base name as the station name is loaded, or if such a file doesn't exist, the file "default.ssf" is loaded, if it exists.
Users	Used to define system users in terms of name, password, access level, and inactivity timeout.

## Coms

Coms (functions included in coms.sll) enhances the remote communications abilities by adding support for the Sutron Speech/Voice modem, alarm detection and transmission with Speech, or via a Hayes compatible data modem, a LOS Radio modem, or a direct connection.

COM ports must be configured for Remote in the autoexec.bat file; factory default is a direct connect on COM 1 with no alarms going out the port. To add support for alarms and/or speech to other COM ports, simply define them in the Coms entry in the *Setup* tab, the system will then reconfigure remote to start running the new configuration immediately and update the autoexec.bat for the next power cycle.

There are two blocks in the graphical setup: the *Alarm* block and the *Coms Tag*, these are available in EzSetup as checkboxes. The *Coms Tag* is used to name points in the system and to specify any speech phrases as appropriate. The *Alarm* block is used to define what levels will trigger alarms.

The terms Alarm and Alert have very specific meaning, described below:

**Alert:** A condition which when triggered will cause the system to transmit immediate messages.

**Alarm:** A condition when one or more sensors exceed their alarm limits.

An Alert can be configured to occur when a sensor goes in to alarm, out of alarm, or both. When an Alert occurs the "Alarm Status:" on the Main menu turns to ALERT!. The system will then attempt to send an alarm message to the various configured devices. By default the software will try a Direct Connect first, then a LOS Radio, a Speech/Voice modem, and then

finally a Data Modem. If at anytime the ALERT is acknowledged, the system status will change to ALARM or NORMAL and the transmissions will stop.

The Direct Connect, LOS Radio, SSP and RS485 blocks are also capable of sending alarm messages on a regular interval. There can be one interval for when the system is in ALARM and another for when everything is NORMAL.

The [Clear] button (on *MAIN TAB*) is used to acknowledge an ALERT! condition manually, causing any alert transmissions to cease. If the system is still in ALARM that condition may be cleared as well by pressing the [Clear] button again, and the system should return to NORMAL until the next measurement occurs and any alarms are redetected.

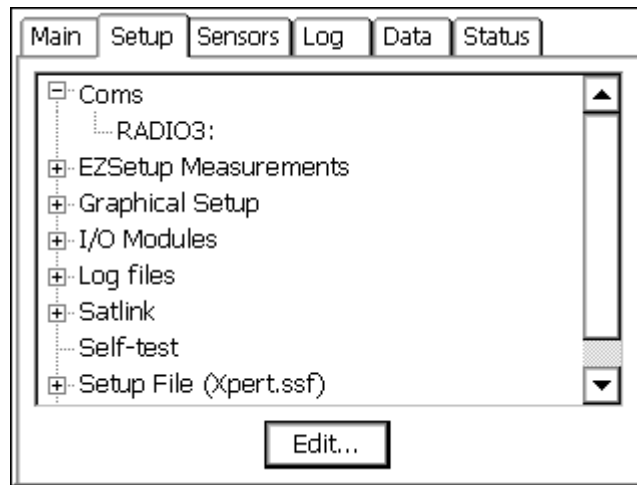

### COM Port Setup Menu

The Setup tab is used to assign the various devices to a port. This is done by clicking *Coms* and pressing [Edit...]. This brings up the Com Port Setup Menu as follows:

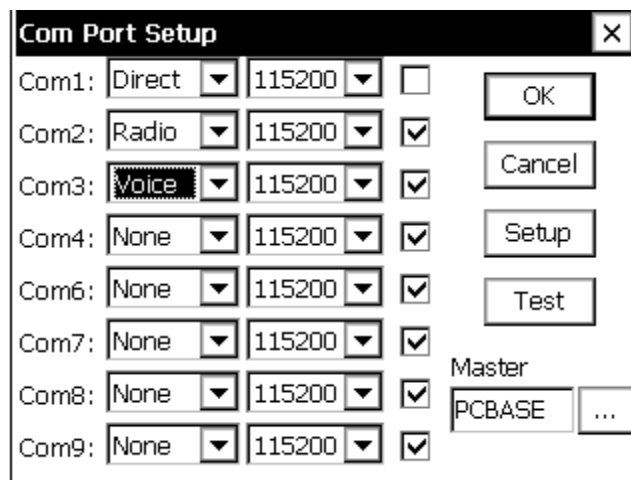

The ports and baud rate you wish to use are selected from this menu. Each port can be configured as None, Direct, Radio, Modem, Voice, SSP or RS-485.

Checking the checkbox next to each port will tell the Xpert to enhance and manage the port above and beyond what Remote alone does. This includes sending out alarms on the port, as well as handling speech dial-in, and dial-out, and support for SSP blocks which can be used to send and retrieve tags, or set the time. Typically, com1 would not be checked, as it is used for Xterm communications to setup the station. You would check it if you wanted to connect a communications device to com1 and see alarm data go out that port.

The Master ID, which is the name of the PC Base Station in an SSP system, is specified here too. Other SSP parameters can be specified in the Setup menu, and pressing the Test button will test communications.

### SSP Settings

Pressing Setup displays this SSP setup menu. This menu will allow additional settings for SSP communications, over a variety of devices. All entries, except # retries, are in units of seconds.

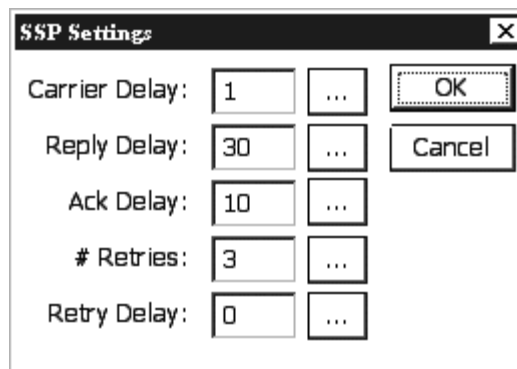

**Carrier Delay:** When the com port is set for "RADIO" communications, this is how long to key the transmitter (assert DTR) to warm up the radio before sending data. With Sutron radios typically 1 second or less is needed, but this may need to be increased if hardware repeaters are used in the network, as each hard-repeater in the network needs time to warm-up.

**Ack Delay:** When the Xpert is acting as a master, this is how long to wait for a response to a request (aka an acknowledgement). The default value is 10 seconds, which is suitable for a single hop 1200 baud system. It may be reduced if higher-baud rates are available, or increased if store and forward repeater hops are necessary.

**# Retries:** More precisely, this is the total number of tries. When an SSP request is made that requires a reply (such as a GetTag) the system will wait for the Ack Delay for the reply. If a reply is not received then one or more retries is performed. # Retries is the total number of attempts to make. The default value is 3. Combined with the default Ack Delay of 10 seconds, this means SSP will send the same message as many as 3 times, with a 10 second delay between each attempt before it will timeout and report a "tx error". All retry messages have the same FLAG SEQUENCE number as the original message. This is used to prevent the same message from being processed twice due to a long network delay.

Reply Delay: When the Xpert is acting as a slave, this is how long the RTU will wait for a message before timing out. This delay includes the time needed for all retries to occur, so it's typically set to the value of AckDelay \* (# Retries). The only situation where the Xpert acts as a slave currently is when it's receiving a new setup from a base station. The Basic GetMessage() function may be used to add slave operations to the Xpert, but the timeout value is specified as a parameter to the function.

Retry Delay: This parameter is rarely used in the software and inserts an extra delay before attempting a retry, and is hence redundant with the AckDelay. Recommendation is to just leave it set to 0.

### Communication Test Menu

Pressing Test displays the following Test Menu. This menu gives communications statistics for the selected COM port along with a way to run some simple tests on the port. Key and UnKey force DTR on and off for the port. Send Mail and Check Mail can be used to communicate with other Xperts or a master station. Mail messages are simple text messages. Pressing Send Mail will cause the system to prompt you for a destination and a message. The destination can be a master station or another field station. For mail to work, you will need to have a dedicated or LOS radio communications link. Send and Check mail use Sutron Standard Protocol (SSP) for the mail messages.

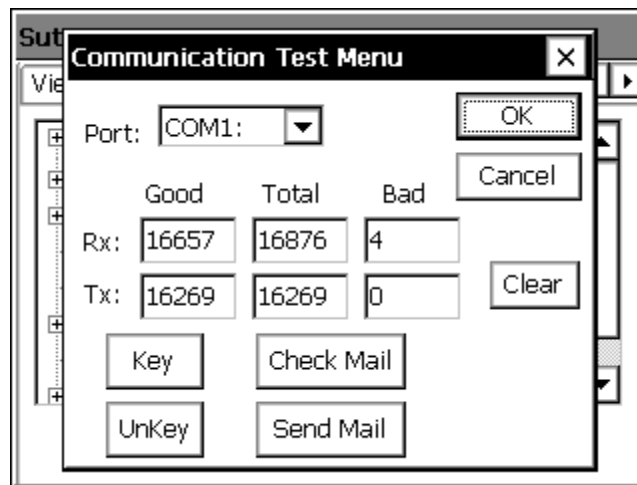

### Coms Configuration Settings

After you define a device under Coms, it is displayed as a sub-item of the Coms entry. See the picture below, where the comms devices "RADIO2:" and "MODEM3:" have been defined.

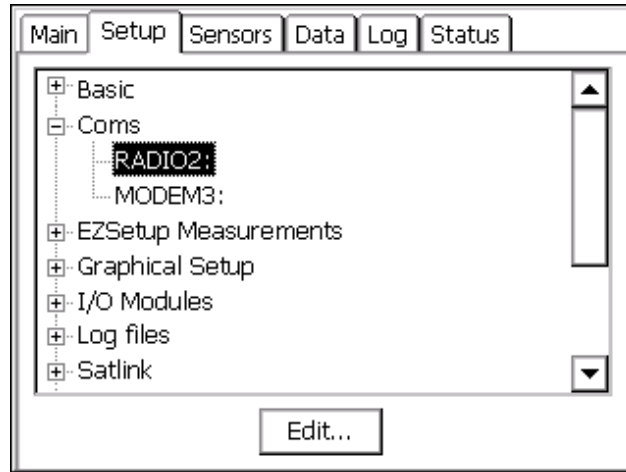

To access the configuration settings for one of these devices, simply highlight the device in the tree, and press the “Edit” button. This will bring up the config settings that are specific to the device selected, which are described in the following sections.

### Direct Connect Settings

This dialog is used to configure the alarm and alert settings for the direct connection.

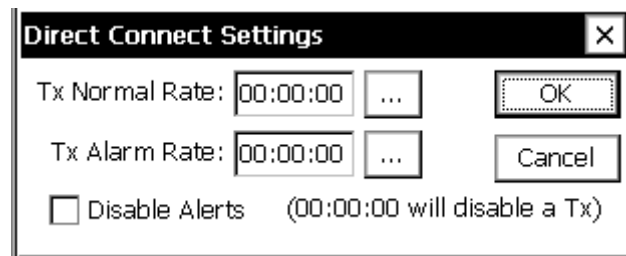

*Tx Normal Rate* is the rate at which alarms are transmitted when no sensors are in alarm, and *Tx Alarm Rate* is the rate used when a sensor is in alarm. They can be set to 00:00:00 to inhibit timed alarm transmissions. *Disable Alerts* may be checked to prevent messages to be sent out the port when the system enters the alert state.

Direct connections support two types of alarm messages. If SSP is detected, an SSP alarm is sent, otherwise a simple text message is sent, and a prompt is made asking for the alarm to be acknowledged.

### Voice Modem Settings

This is the Voice Modem settings screen.



When an alert occurs each phone number is tried in sequence starting with Phone #1, until an acknowledgement occurs. Or until the # Redials has been attempted on each number. The Answer mode can be configured to answer in Voice, Data, or Voice & Data. The Voice & Data mode prompts when it answers the phone to “Please press pound”. If the person dialing in presses the “#” key on the telephone a voice message is spoken, otherwise a data carrier is transmitted and a data connection is attempted. The Dial-in and Dial-out buttons allow the Dial-in and Dial-out messages to be configured. Speech phrases are stored in the \Flash Disk\speech\English directory or \Flash Disk\speech\[*language*] directory depending on which language is selected.

By default the voice modem will speak the specified Dial Out message. If the modem is unable to detect “ring-back” it may start speaking a phrase before someone answers the phone. Because of this, the message spoken should either be repeated or wait for a button to be pushed before speaking the alarm data. If a Dial Out message is not defined or the letter “D” is placed at the beginning of a phone-number then a data alarm will be sent. The data message will try to automatically detect a PC Base Station and send an SSP message, otherwise a simple text message is sent and a prompt is made asking for the alarm to be acknowledged.

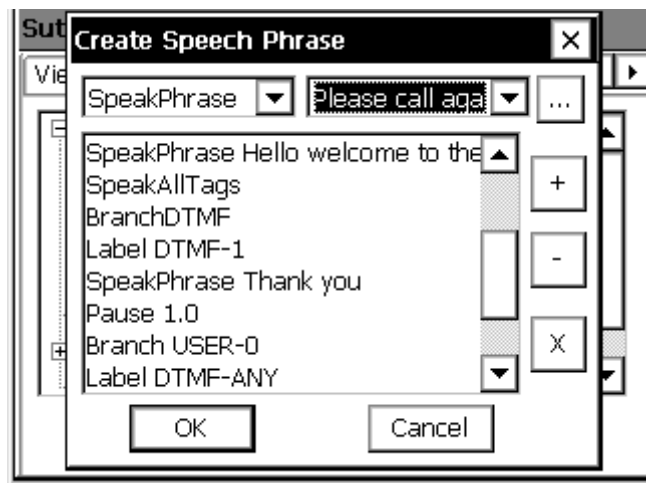

Above is an example of the speech phrase editor screen. The combo box in the top left is used to select a speech command (such as “SpeakPhrase”). The combo box in the top middle is used to select any optional parameters (such as the phrase to speak in this example). The [...] button is used edit and/or add the command to the command list. [+] is used to move a phrase up in the list, and [-] is used to move a phrase down. [x] can be used to delete a phrase from the list.

### Speech Dial-in and Dial-Out commands

Command	Description
AckAlarms	Acknowledges alarms in the system. Further alert transmissions will cease until a new alert occurs or it's time for an alarm transmission.
Branch	Branches to another part of the speech command specified by a user Label. Searching for the label begins with the first line in the speech command.
BranchDTMF	Waits for and branches based on a DTMF press. Searching for the label begins at the current line in the speech command. The phone will be hungup after 60 seconds if a button is not pushed.
BranchNoDTMF	Same as Branch, but the Branch is only performed if a DTMF button was <b>not</b> pressed on the phone. This is usefull for repeating a series of phrases over and over until the user pushes a button. If a button is pushed, it will be queued, and should be processed by a BranchDTMF command. Normally there is a 90 second inactivity timeout that is reduced to 60 seconds when this command is used. The phone is hungup if an inactivity timeout occurs.
Hangup	Hangsup the phone and terminates the speech command
InputManual	Inputs a number from the user. The number is entered with the DTMF keypad. “*” may be used to specify a decimal point. Press the “#” button is used to indicate the end. Pressing “*” twice will allow the number to be re-entered. See SpeakManual, and StoreManual.  Example: 12*345#  would enter the number 12.345. Negative numbers are not supported.
Label	Labels a section of the speech command, two types of labels exist. User and DTMF. DTMF labels are branched to in response to the BranchDTMF command, and user labels are branched to using the Branch command.
Pause	Delays the speech command for the specified number of seconds (resolution down to milliseconds)
SpeakAlarms	Causes all sensors with an attached ComTag to have their prefix phrase, value, suffix phrase and alarm status spoken.

---

SpeakAllTags	Causes all sensors with an attached ComTag to have their prefix phrase, value, suffix phrase and alarm status spoken.
SpeakData	Speaks just the last measured data value of the specified sensor.
SpeakLiveData	Forces measurement and speaks just the live data value of the specified sensor.
SpeakLiveTag	Forces measurement and speaks the prefix phrase, live value, suffix phrase and alarm status of the specified sensor.
SpeakManual	Speaks the last data entered by the user with the InputManual command (or 0 if no value has been entered).
SpeakNum	Speaks the specified number.
SpeakPhrase	Speaks the specified phrase.
SpeakTag	Speaks the prefix phrase, value, suffix phrase and alarm status of the specified sensor.
StoreManual	Stores the last data entered by the user with the InputManual command (or 0 if no value has been entered) in to the specified tag. This allows the user to change operating values of the system (use WaitForPass to authorize).
WaitForPass	Pauses until the user enters a DTMF sequence which matches the specified sequence. The system will timeout if the user doesn't enter a code in less than one minute.

---

Use *Branch USER*, *BranchDTMF*, and *Label*, to build a menu system.

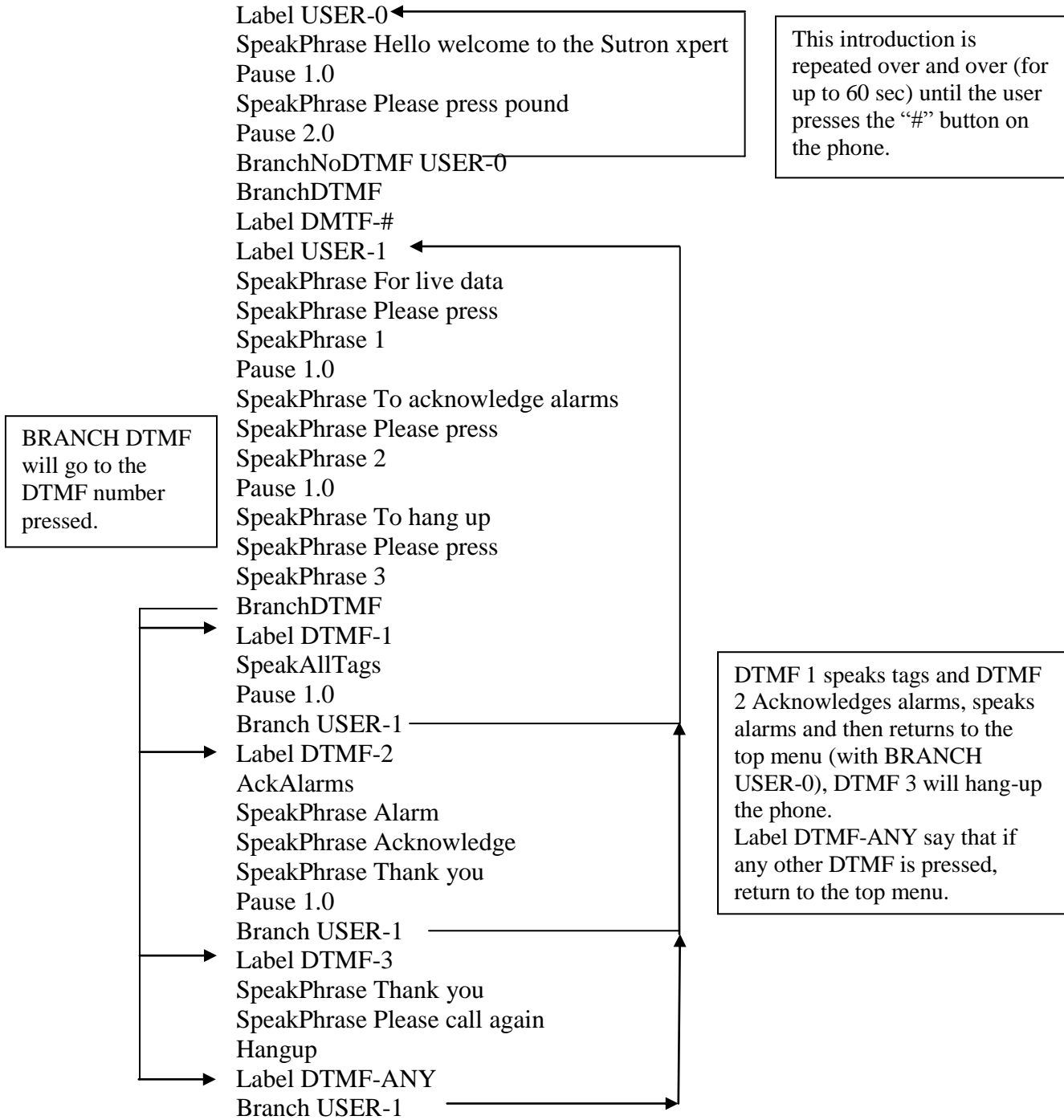

## LOS Radio/ SSP / RS-485 Settings

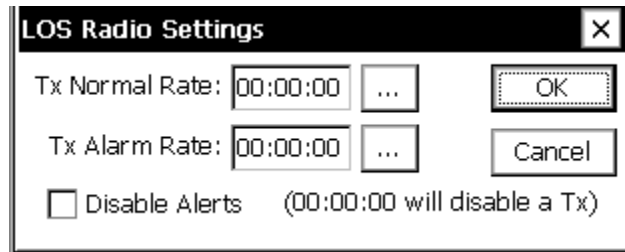

This is the LOS Radio settings screen. There are only three settings here. The Tx Normal Rate is the rate at which alarms are transmitted when no sensors are in alarm, and the Tx Alarm Rate which is the rate used when a sensor is in alarm. They can be set to 00:00:00 to inhibit timed alarm transmissions. Disable Alerts may be checked to prevent messages to be sent out the port when the system enters the alert state.

The LOS Radio only supports sending alarms to PC Base Stations using SSP (Sutron Standard Protocol).

The SSP and RS-485 options are very similar to the LOS Radio option. The primary difference being that SSP assumes a direct (SSP Only) serial connection between two devices, and RS-485 assumes there is an RS-485 connection. The difference is in how the control lines are used, but the options are the same.

## Data Modem Settings

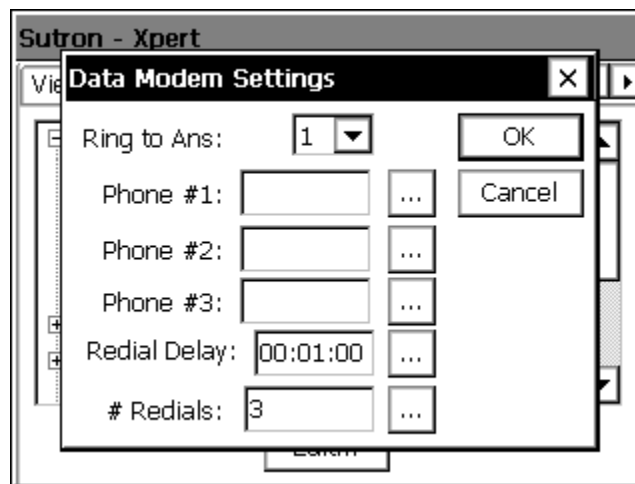

This is the Data Modem settings screen. When an alert occurs each phone number is tried in sequence starting with Phone #1, until an acknowledgement occurs. Or until the # Redials has been attempted on each number. The redial delay causes a pause between each redial attempt.

The Data Modem connection support two types of alarm messages. If a PC Base station is detected, an SSP alarm is sent, otherwise a simple text message is sent and a prompt is made asking for the alarm to be acknowledged.

## EzSetup Measurements

EZSetup is used to define simple sensors based on a measurement interval. Sensors configured here may be measured or averaged on a regular interval, have a simple slope and offset applied, displayed on the front panel, transmitted via Satlink or modem and be used to identify alarm conditions. It is possible to configure an entire station using only this section for sensors, if no special processing is needed.

Measurements that are set up in EzSetup work in parallel with measurements set up in the Graphical Setup. Hence, one popular practice is to set up simple sensor configurations in EzSetup, and more complicated sensor configurations in Graphical Setup.

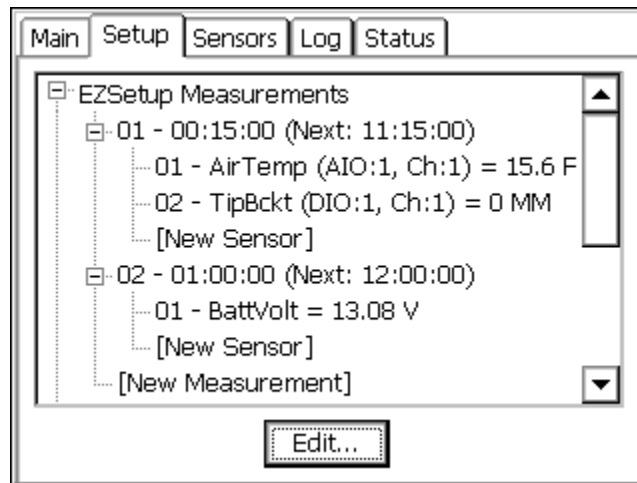

EzSetup organizes sensors by measurement schedule, similar to the way the 8210 data logger worked (though the Xpert can have multiple measurement schedules). Each measurement schedule has a set of sensors assigned to it. Whenever the measurement schedule executes, the sensors are measured.

In the example above, two measurement schedules have been defined. The first schedule will measure "AirTemp" and "TipBckt" every 15 minutes. The second will measure "BattVolt" every hour. You can see the next measurement of AirTemp and TipBckt will occur at 11:15:00, and that the last measured values for each of these parameters were 15.6F and 0MM. Note: this status informatino does not update automatically. To update, select the root entry "EZSetup Measurements", and press the "Refresh" button.

Editing a measurement or sensor requires recording to be turned off. When you try to create or edit a measurement or sensor, the system will prompt you to stop recording. When the create or edit is complete, the system will prompt you to restart recording.

The measurements and sensors you define in EzSetup are stored in the Xpert setup file. If a setup file has been defined, it is saved automatically after making changes to EzSetup and leaving the Setup tab. You may also explicitly save the setup by selecting the "Setup" entry, and pressing the "Save As" button.

## Measurement Schedules

To create a new measurement schedule, select the “[New Measurement]” entry and press the “Edit” button. To edit an existing measurement, select the entry in the tree and click “Edit”. To delete a measurement schedule, select the entry and click “Delete”. When creating or editing a measurement schedule, the following dialog is shown:

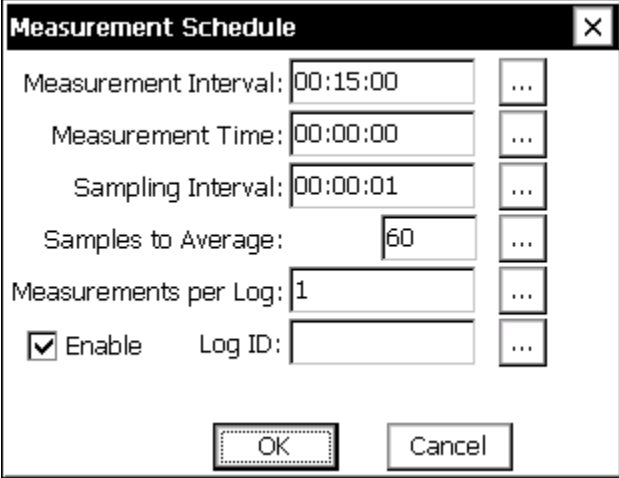

Measurement Interval:	00:15:00	...
Measurement Time:	00:00:00	...
Sampling Interval:	00:00:01	...
Samples to Average:	60	...
Measurements per Log:	1	...
<input checked="" type="checkbox"/> Enable	Log ID:	...

OK Cancel

**Differences from an 8210:** Editing an EzSetup measurement is very much like the measurement schedules on the 8210 with a few differences. The 8210 has two fields named Power Time and Sampling Time which are not supported, and the order of processing has also been changed a little. Specifically, on the Xpert, all the non-averaged sensors are measured first, so these measurements occur as close as possible to the measurement time. Then averaging starts immediately following, and continues until either the “Samples to Average” is exceeded or the average time has expired. The average time expires when the next scheduled Measurement Interval is to start or the sampling window defined by the Sampling Interval and Samples to Average is exceeded.

**MEASUREMENT INTERVAL:** Specifies how often the measurement is performed.

**MEASUREMENT TIME:** Specifies when the measurement is performed. This is can be viewed as an offset into the measurement interval and will typically be 00:00:00 as shown above. Setting it to 00:05:00 would cause the measurments to occur at 5 minutes, 20 minutes, 35 minutes, and 50 minutes past the hour. In other words, at 00:05:00 and every 15 minutes thereafter.

**SAMPLING INTERVAL:** For sensors with averaging enabled, the sampling interval specifies the timing between samples. Note: This should be at least as long as the time required to take the samples. If not, the “Samples to Average” takes on a new meaning described below.

**SAMPLES TO AVERAGE:** Specifies how many samples to take in averaging a sensor. Note: The sampling interval along with the samples to average defines a sampling window over which the samples will be taken. Sixty samples taken at a one second interval defines a sixty second sampling window. In situations where the sampling interval is shorter than the time required to take the samples, the unit will take consecutive samples for the duration

defined by the sampling window. In other words, if an SDI-12 sensor that took 2 seconds was being measured by the above setup, the averaging would be for 60 seconds (00:00:01 times 60) instead of 120 seconds needed for 60 samples. The unit must collect over half of the samples before the average will be marked with a “G” as good.

**MEASUREMENTS PER LOG:** Allows extra measurements to be taken which are not all logged. For instance, a value of 4 with a 00:15:00 interval would cause the 9210 to measure every 15 minutes, but log the specified sensor only every hour.

**ENABLE:** This button is a quick way to disable a measurement if there’s a temporary issue that doesn’t warrant completely deleting it.

**LOG ID:** When this field contains a string, all sensors associated with this measurement are logged as a group, with the Log ID used as the data set’s name. When the Log ID field is empty, all items are logged separately, each with it’s own time stamp, units, and quality data. NOTE: The maximum size of a log entry is 2048 bytes. Hence, be careful to not create a Log ID that results in an entry larger than that. Also note that only 256 bytes of data can be shown for each log entry on the Log tab. Of course, all 2048 bytes are included in an export of the log.

After creating or editing a measurement schedule, it’s tree entry is shown collapsed. Expand the entry by clicking the "+" plus sign. This will show all the sensors assigned to the schedule. The order in which the sensors appear is important, as it determines the order in which the sensors are measured and logged.

## Sensor Configuration

A new sensor is added to a measurement schedule by selecting “[New Sensor]” and pressing “Edit”. To edit an existing sensor, select the entry and press “Edit”. To delete a sensor, select it and press “Delete”. When creating or editing a sensor, the following dialog is shown:

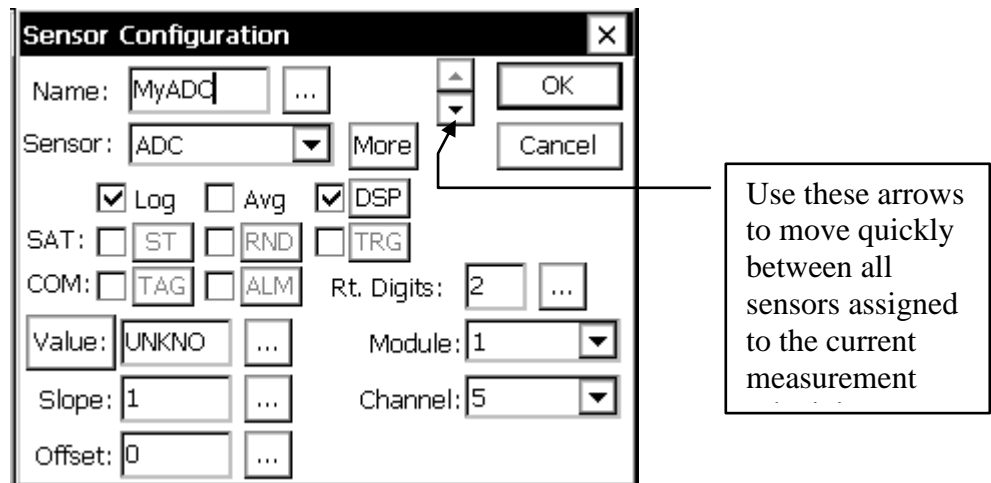

**NAME:** The name used when logging (except when Log ID is active), and when displaying the sensor value (in the EzSetup menu, the Sensors Tab, and the Xpert front panel display).

**SENSOR:** Defines the sensor type to measure. Click the box to see the list of all possible sensor types. Note that each of these sensor types correspond to a sensor block that can also

be used in the graphical setup. This means that all the descriptions for sensor blocks in Appendix A apply to the sensor type you select here.

**MORE:** This button brings up the configuration dialog for the selected sensor. See Appendix A for details on how to change the configuration. Note: Most sensors have many more important settings than can be shown on the EzSetup Sensor Configuration dialog. The additional settings are accessed by pressing “More”.

**LOG:** When checked, the system logs the output to ssp.log. Logging to ssp.log, as opposed to a log specified by the user, ensures the data is available through legacy telemetry channels. When ssp.log does not exist, the user is prompted to create it when leaving Setup.

**AVG:** When checked, the system averages the sensor according to the sampling schedule defined in the measurement schedule. **NOTE:** When using EzSetup to average both speed and direction of either the RMYoung and GillWind sensors, the system computes a **unit vector** average of wind direction, and a **scalar** average of wind speed. However, this is only the case when the sensors have been set-up properly, where the system considers speed and direction as coming from the same sensor (i.e., the sensor outputs are “linked”). You can verify proper setup by ensuring the speed and direction parameters are grouped together under the sensor entry. The following shows a proper setup for RMYoung.

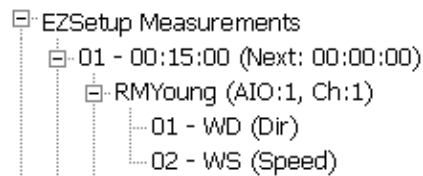

See the section “Multi-Output Sensors” for more information on how to ensure sensors with multiple outputs are set up properly.

**DSP:** When checked, the sensor will be included when displaying current values from the Xpert front panel. Pressing the DSP button will bring up a dialog that allows you to change the name and precision of the value shown on the front panel.

**SAT-ST:** Checkbox enables Self Timed transmissions for this sensor. Clicking the ST box will bring up additional properties, see Self-Timed Parameter block in Appendix A for details on settings.

**SAT-RND:** Checkbox enables Random transmissions for this sensor. Clicking the RND box will bring up additional properties, see Random Parameter block in Appendix A for details on settings.

**SAT-TRG:** Checkbox enables this sensor to trigger random transmissions. Clicking the TRG box will bring up additional properties, see Random Group block in Appendix A for details on settings.

**COM-TAG:** Checkbox enables this sensor for Coms. Clicking the TAG box will bring up additional properties, see Coms Tag block in Appendix A for details on settings.

**COM-ALM:** Checkbox enables this sensor for alarms via Coms (modem, LOS, etc.). Clicking the ALM box will bring up additional properties, see Coms Tag block in Appendix A for details on settings.

**VALUE:** The Value box shows the last measured value for the sensor. Press the value button to take a reading immediately and display it. Editing the value (by pressing ...) will modify the Offset such that future readings will equal the entered value. Simply set the offset back to 0 to undo this.

**RT. DIGITS:** Sets the number of right digits used when displaying and logging the sensor.

**SLOPE/OFFSET:** The current slope and offset assigned to the sensor.

**MODULE/CHANNEL/PORT/ADDR:** These settings mirror those found in the sensor configuration dialog. The setting will appear only when the selected sensor type supports the property. For example, when the sensor type is ADC, the Module and Channel properties are shown in the Sensor Configuration dialog, as well as on the dialog that appears once “More” is clicked. Note: Most sensors have many more important settings than can be shown on the EzSetup Sensor Configuration dialog. The additional settings are accessed by pressing “More”.

**PARAMETER:** Appears when a sensor has more than one possible output. For instance an AT/RH sensor has both an air temperature, and a relative humidity output. Select the one to measure.

### Multi-Output Sensors

Several sensors have more than one output parameter to select for measurement. For example, the SDI-12 sensor offers output parameters 1 through 20, the RMYoung and GillWind sensors offer output parameters “Speed” and “Dir”, and the Counter sensor provides “Count”, “DeltaCount”, and “Freq” output parameters. When a sensor with multiple outputs is selected in the Sensor Configuration dialog, the dialog allows the user to select the output parameter to use (see “Parameter” in the dialog, below).

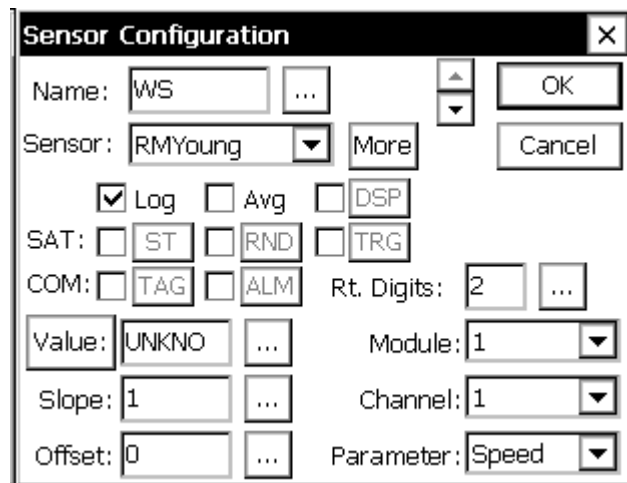

**When you want to measure more than one output of a multi-output sensor, you must set up a separate sensor entry for each output to be measured.** When each output is set up properly, the system makes only one measurement of the sensor, as opposed to a separate measurement for each output. This is especially important for sensors that take a significant time to measure (imagine taking 5 separate measurements to obtain 5 parameters from an

SDI sensor that takes 30 seconds to measure!). In addition, for some sensors, it may be important to ensure parameters were measured at the same time.

To ensure only one measurement is made for all outputs of a single sensor, **the I/O device configuration for each sensor entry representing a separate output, must be the same.** The I/O device configuration consists of different parameters for different types of sensors. If the sensor reads an analog input, then the analog input's module and channel must be the same. If the sensor reads a com port to obtain its input, then the com port must be the same. For SDI-12 sensor's, the SDI-12 address and command must be the same. Note: the I/O device configuration must be set the same **when creating the sensor entry.** Changing the configuration to be the same after the entry has been made, does not result in "linking" any outputs.

In the example below, the Dir and Speed outputs of the RMYoung sensor are linked. One measurement of the sensor will be made every 15 minutes to obtain both values, Dir and Speed. The same is the case for the GillWind sensor on COM4. However, the GillWind sensor on COM5 does not have it's outputs linked. This would happen if, for example, the Speed sensor entry was created with the selection of COM7 and then changed to COM6 to match the Dir entry.

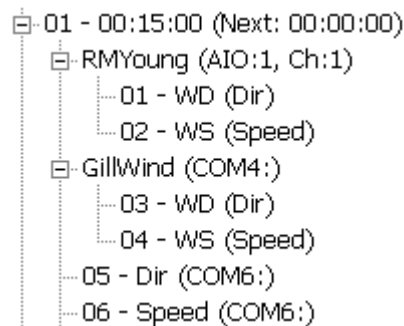

Once outputs are linked, **a change to one will affect all linked outputs.** Using the above as an example, if you select the GillWind Dir entry and change it's com port to COM3, it will change for the Speed setting as well.

Once an output has been linked, you must delete the entry to "unlink" it. Hence, to fix the fact that the Speed output of the GillWind sensor on COM6 is not linked to the Dir output, you would first delete the Speed entry, and then re-add it, making sure to set the com port setting to COM6 in the process.

### Event Driven Sensors

The vast majority of sensors measure when told to, i.e., according to the measurement schedule you define. The exception to this rule occurs when using a sensor with an *Event* option checked (like BinIn). Every time an *Event* occurs, the entire set of sensors defined under the measurement schedule will be measured. For example, if you had an EZSetup measurement schedule with the BinIn block (*Event checked*) and an sdi-12 sensor, every time the BinIn detected a change of state, the SDI-12 sensor would also be measured.

## Graphical Setup

The *Graphical Setup* branch of the Setup tab is used to manage the portion of the system's setup that has been defined by interconnecting graphical blocks, where each block represents a function such as sensor, measure, or log. This method of setup should be used to define sensors that can't be setup using the *EZSetup Measurements*. This would include sensors that need to have a polynomial, interpolation table or any other special processing done to them.

See the section in Appendix A that covers Processing blocks to see all the available processing. See Chapter 4: Setup Diagrams, for detailed descriptions of how to set up sensors in this way. This is also where setups defined with versions before 2.0.0.0 will be loaded.

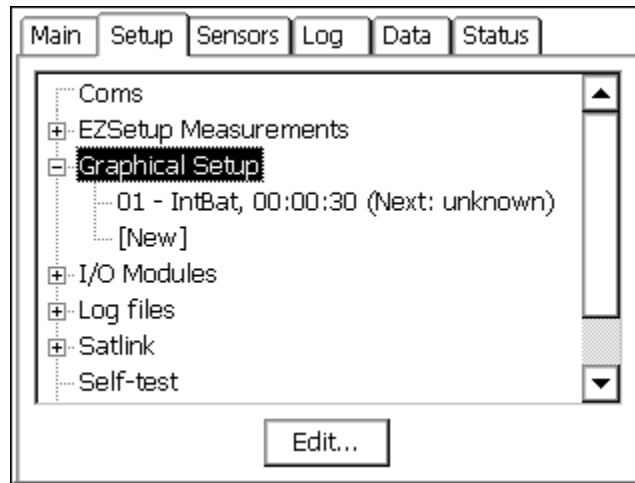

The details of whatever measurements have been graphically defined will be displayed underneath the *Graphical Setup* main branch. Some of the details shown for each measurement include: sensor name, channel usage, last data value and quality (quality only if it is bad), and scheduling information, including the time of the next measurement.

Selecting a measurement sub-branch and pressing *Edit* will cause the system to display the measurement graphically, i.e., in terms of the blocks that define it. Only the blocks of the measurement selected will be displayed.

To display the blocks of all measurements that have been defined graphically, select the *Graphical Setup* branch and press *Edit*.

Press the *View* button to view the block diagram in read-only mode.

To define a new measurement graphically, select [New] and press *Edit*. This causes the system to display the graphical setup page with no blocks yet defined.

To remove an entire graphical block chain, click it, click *EDIT* and then click the left most block and do a delete righ

## I/O Modules

The I/O modules branch displays the I/O modules currently connected to the system. These modules are used for hooking up all sensors to the system except SDI-12 sensors. Up to ten

modules can be connected together and then plugged into the I2C port at the bottom of the logger. Specific details on individual modules can be found in Appendix C.

If you select an I/O module in the *Setup* tab and press *Edit...* the following dialog will appear. This dialog gives the serial number of the I/O module, its name and its I2C address. Only the I/O module number can be changed. This number is stored into the flash of the I/O module, so it remembers it on power cycles.

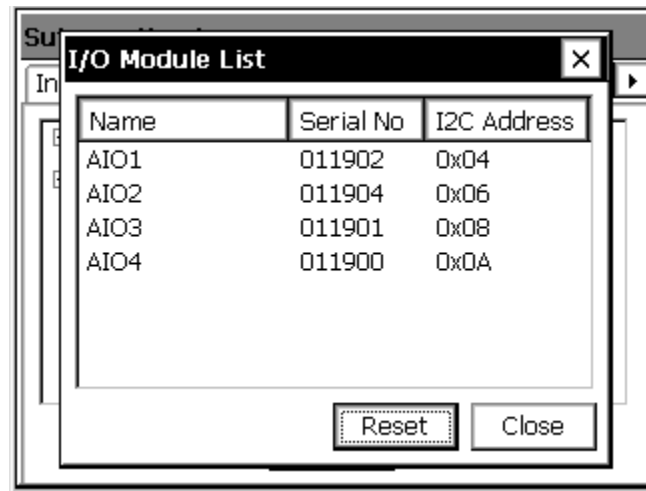
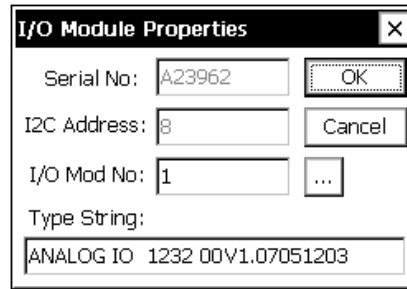

The number of the module can be changed. It is common for modules to be named AIO1 (Analog I/O Module #1), AIO2 (Analog I/O Module #2), rather than by the serial numbers. Naming the modules also simplifies the process of changing one module for another. The system must not have more than one type of module with the same number, I.E. If a system has two analog modules both modules cannot be module number one, but it is possible to have a digital module one and an analog module one.

Pressing *Reset* will “reboot” the I2C bus, it is similar to disconnecting and reconnecting the modules. This is only needed if a module that is connected does not show up in this list.

## Log Files

The *Log Files* branch of the *Setup* tab allows management of all the log files that have been added to the system. Multiple log files can be stored in physical memory space, only limited by the amount of memory in the system. Multiple files can be open at one time; therefore, ten sensor signals can be logging to ten separate files (or to five files or one for that matter).

## Log Directory

To display a more detailed directory of the log files in the system, click *Log files* and then press the *Edit...* button at the bottom of the screen:

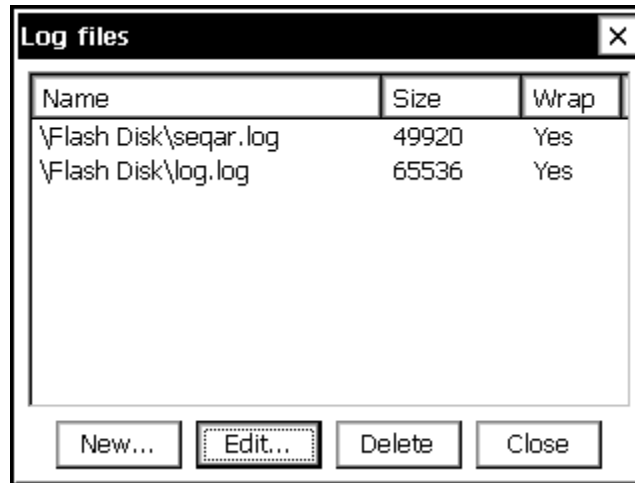

For each log file, this window lists the name of the file (\\location\\name.log), the size of the file, and whether or not the file should wrap. The file size is the maximum size of the log file in bytes. Wrap specifies what should happen once the file has been filled up to its maximum size. If wrapping is set to 'Yes' and the file fills up, the system will delete some of the old data to make room for the new data. This way the log file will always be full of the most recent data. If wrapping is set to 'No' and the file fills up, the system will not store the additional data in the log and the new data will be lost.

## Sizing Logs

Since each logged data point takes between ten and fifteen bytes of memory, a log file 60,000 bytes in size will hold between 4000 and 6000 data points, or between 1.5 and 2 months of a single sensor measurement, made every 15 minutes.

## Log Properties

Pressing the *New...* or *Edit...* button in the above screen brings up the log file properties box as shown below. This is where the filename, maximum size, and wrap (discussed above) are set. If a new log file is being created, it might take a minute or two after pressing OK for the file to be initialized.

NOTE:

Use \\Flash disk\\filename.log to store log files into internal flash.

Use \\Storage card\\filename.log to store file onto a PCMCIA ATA flash card.

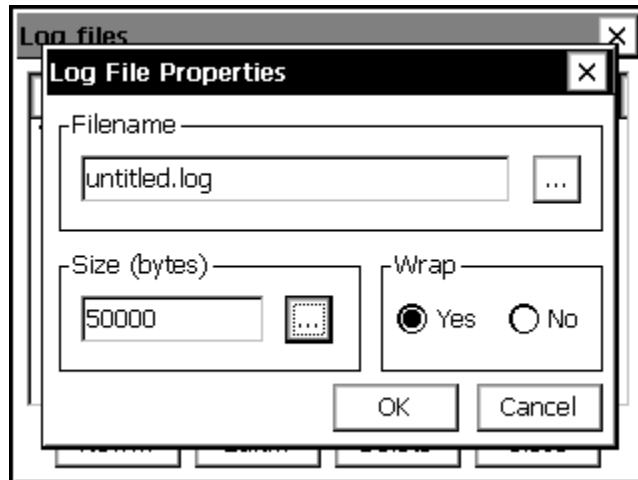

You can change the size of an existing log from this dialog. The size can be increased without losing any data currently in the log. If the size is decreased, you will lose some of the data in the log. **If you are decreasing the size of the log, you may want to retrieve the data from the log so it is not lost.**

## Satlink

The *Satlink* branch is used when you have a Sutron Satlink transmitter connected to the Xpert. This branch is used to manage the details of the setup for both self-timed and random transmissions.

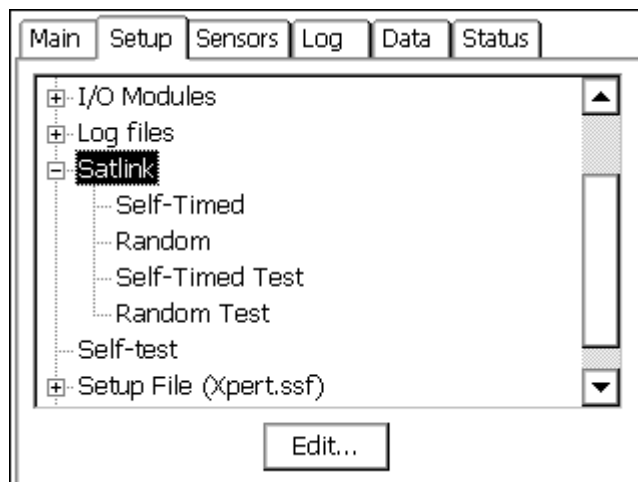

## Satlink Dialog

Selecting Satlink and pressing Edit brings up the main Satlink dialog.

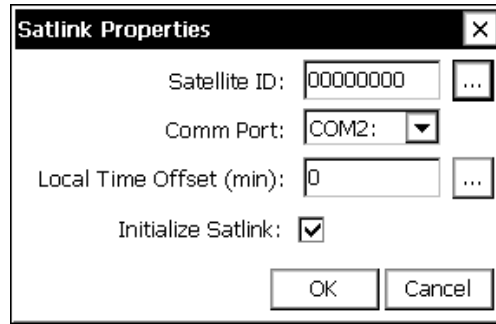

### Satellite ID

This property is the *Satellite ID* for both self-timed and random transmissions. The *Satellite ID* is a hexadecimal number, 8 digits long, assigned by NESDIS, EUMETSAT or some other authorizing agency.

### Comm Port

The *Com Port* property identifies the COM port to which Satlink is connected. Satlink connects to the comm. port using a standard DB9 serial cable.

### Local Time Offset

The *Local Time Offset* property defines the difference between the current local time and UTC (Universal Time Coordinated). This offset is sent to Satlink at recording start. The offset is specified in number of minutes, and may be negative. The Xpert uses the local time offset and the UTC time received from Satlink to set the Xpert's clock. In addition, the offset is sent to Satlink (Satlink 2's use this value to determine local time).

### Initialize Satlink

The *Initialize Satlink* check box controls whether or not to send transmission settings to Satlink at the start of recording. When this box is checked, the transmission settings (times, rates, channels, etc.) are sent to the Satlink whenever the unit is started, otherwise, settings are not sent to the Satlink, but assume instead that Satlink has been configured by some other program (e.g., *Satlink Communicator*).

### Self-Timed Dialog

The Self-Timed dialog allows the setting of the Self-Timed transmission properties. The properties correspond to settings that will be sent to Satlink to configure it as well as settings that will be used to make the transmission. A typical dialog is shown below followed by a brief explanation of each property.

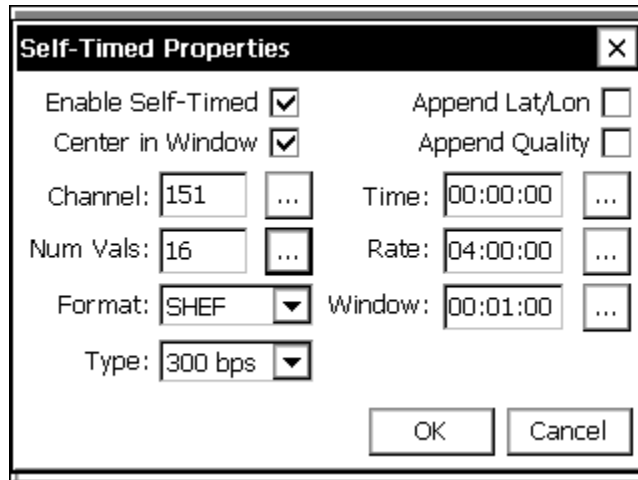

### **Enable Self-Timed**

This box must be checked for the system to make self-timed transmissions. This field is sent to the Satlink to configure it and uses the field to control its own scheduling.

### **Center in Window**

This box instructs Satlink to center each timed transmission in the transmission window. Normally, a transmitter has a transmission window that is larger than the length of the transmission it must make. When “Center in Window” is selected, Satlink will delay each transmission so it is centered in the window. The Window size is entered in the Window Property on this dialog.

### **Append Lat/Lon**

Satlink transmitters have a GPS (Global Positioning System) receiver which is capable of determining its latitude and longitude. This check box instructs Satlink to add the Latitude and Longitude to the end of each transmission.

### **Append Quality**

This check box configures Satlink to append quality data to the end of the transmission. Note: as of version 4.11 of Satlink, Satlink has not yet implemented this function.

### **Channel**

This property defines the channel that Satlink will use to make the self-timed transmission.

### **Num Vals**

This property defines the number of values to include in the self-timed transmission. This value is used only in the BIN-INT transmission format to set the number of values to send for each sensor (e.g. if set to 32, and if 4 sensors are sending data, then a total of 128 data values are sent). Other formats may use the NUM VALUES defined in the self-timed blocks entered into the setup. The number entered here will also set the default value when placing a self-timed block into the setup.

## Format

Support for several standard formats is included. The supported formats are:

- “SHEF” format conforms to NESDIS Standard Decimal format specifications. The format is ASCII and readable by persons without the aid of a computer.
- “SHEF Fixed” is a special version of the SHEF format where numbers are fixed to seven decimal points. Receive sites that handle messages with variable length data can use this format.
- “Bin Int” is a binary interleaved format, identical to the 8210 binary transmission format. The data are in the 6-bit pseudo binary format required by NESDIS.
- “Bin NonInt” is a binary non-interleaved format. This format also uses the 6-bit pseudo binary format but allows different amounts of data to be sent for each sensor. The data is not interleaved, i.e., one sensor’s data set appears together in the transmission.
- “NOS” conforms to NOS requirements for its tidal stations.
- “NIFC” conforms to NIFC requirements for its fire weather stations.
- “NFDRS” conforms to NFDRS requirements for its fire weather stations.
- “INSAT” conforms to INSAT requirements for its stations.
- "HANDAR" is a format where sensors are separated by <CRLF>, sensor data is separated with a space and missing data is an "M". The oldest data is first (to left), as in:

```
010034380517419:21:30G42+0NN155E9200070"  
1.3 1.3 1.3 1.3  
2.4 2.4 2.4 2.4  
M 12.2 12.2 12.2 12.2 12.3 12.3 12.3
```

## Type

The Type property defines the baud rate for the transmission. The valid selections are 100, 300, 1200, MSG (for METOESAT), and INSAT.

## Time

Time is the transmission time assigned to the station. Each station will have a unique transmission time, rate and channel assigned by NESDIS, EUMETSAT or other authorized agency. The transmission time is entered in UTC.

## Rate

The Rate, along with the transmission time determines when transmissions are made. The units for the rate are HH:MM:SS. Typical rates are 01:00:00 for hourly transmissions and 04:00:00 for transmissions every 4 hours.

## Window

This property defines the size of the window, in HH:MM:SS, that is given for the transmission. Satlink only uses this window size if the box “Center in Window” is checked.

## Random Dialog

The Random Dialog allows the setting of the Random transmission properties. Random transmissions are those that are made at random intervals. The properties correspond to

settings that will be sent to Satlink to configure it as well as settings that will be used by software to make the transmission. A typical dialog is shown below followed by a brief explanation of each property.

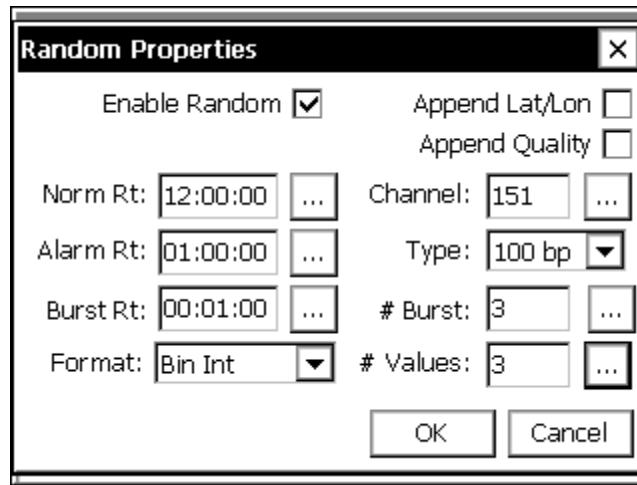

### **Enable Random**

This box must be checked for the system to make random transmissions. This field is sent to the Satlink to configure the transmitter and uses the field to control its own scheduling.

### **Append Lat/Lon**

Satlink transmitters have a GPS (Global Positioning System) receiver which is cable of determining its latitude and longitude. This check box instructs Satlink to add the Latitude and Longitude to the end of each transmission.

### **Append Quality**

This check box configures Satlink to append quality data to the end of the transmission. Note: as of version 4.11 of Satlink, Satlink has not yet implemented this function.

### **Norm Rt**

The “Normal Rate” property defines how often random transmissions will be made, when the unit is not in alarm. The rate is specified in HH:MM:SS.

### **Alarm Rt**

The “Alarm Rate” property defines how often random transmissions will be made when the unit is in alarm, following burst transmission(s). The rate is specified in HH:MM:SS.

### **Burst Rt**

The “Burst Rate” property defines how often the “# Burst” random transmissions will be made. These burst transmissions occur when the unit first goes into alarm. The rate is specified in HH:MM:SS.

## **Format**

Several formats are supported for random transmissions:

“Bin Int” is a binary interleaved format, identical to the 8210 binary transmission format. The data are in the 6-bit pseudo binary format required by NESDIS.

“Bin NonInt” is a binary non-interleaved format. This format also uses the 6-bit pseudo binary format but allows different amounts of data to be sent for each sensor. The data is not interleaved, i.e., one sensor’s data set appears together in the transmission.

## **Channel**

This property defines the channel that Satlink will use to make the random transmission.

## **Type**

This property defines the baud rate for the transmission. The valid selections are 100 and 300.

## **# Burst**

The “# Burst” property defines how many transmissions Satlink will make when the unit first goes into alarm. This value is normally set to one. When set to a value other than one, Satlink will make this number of transmissions with each transmission separated by Burst Rate number of seconds.

## **# Values**

This property defines the number of values to include in the random transmission. This value is used for the BIN-INT transmission format to set the number of values to send for each sensor (E.G. If set to 32 and 4 sensors are sending data, then a total of 128 data values are sent), other formats will use the NUM VALUES defined in the random parameter blocks in the setup. The number entered here will also set the default value when placing a random parameter block into the setup for BIN-NONINT format.

## **Self-Timed Test**

The Self-Timed Test dialog is used to make a test transmission, see the selected format of a self-timed transmission and see the detailed status of the transmitter. Pressing the Send button makes test transmissions. Before pressing *Send*, Satlink must be set up with valid information on both the Satlink dialog and Satlink self-time dialogs. Test transmissions should only be made on special test channels, or with the Satlink connected to a dummy load. Otherwise, the transmission may interfere with other stations. The test message that will be sent is displayed in the text box to the left of the send button. Change the message by selecting custom and then changing the message using the ... control.

If the setup has been entered, this dialog will display the Current Message that would be transmitted if one were sent by the system. Along with the message, the dialog displays the number of characters in the message and the amount of time that would be needed to make the transmissions. These will be useful things to examine to help make sure the set-up is correct.

To see the detailed status from the transmitter, press the Status button.

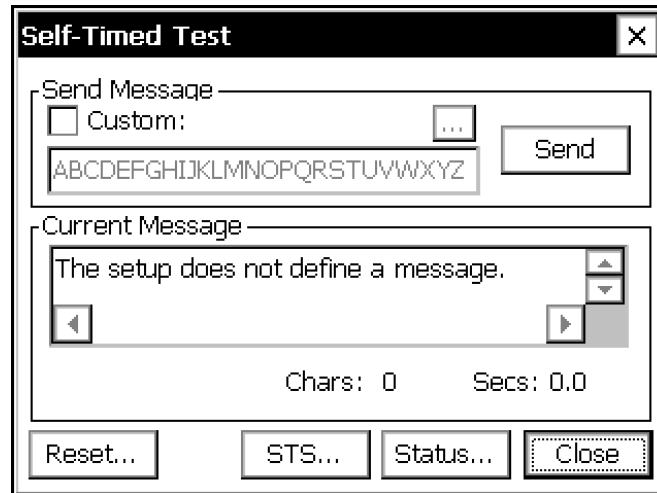

Pressing the “Reset” button will send a command to the Satlink to reset (reboot). This might be necessary in the rare case where the Satlink has a problem that can only be cleared by reset, but no one is at the station do cycle power.

To send a Send-to-Sutron test message, press the *STS...* button. The following dialog is displayed allowing an STS transmission to be made.

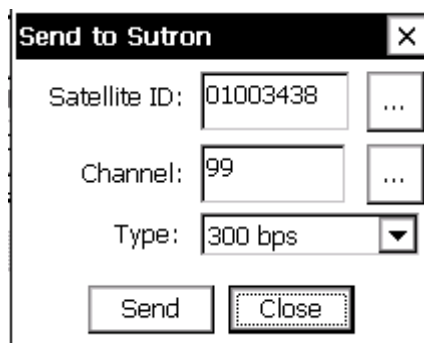

## Random Test

The Random Test dialog is used to make a test transmission, see the selected format of a random transmission and display the detailed status of Satlink. Pressing the Send button makes test transmissions. Before pressing *Send*, Satlink must be set up with valid information on both the Satlink dialog and Satlink random dialogs. Test transmissions should only be made on special test channels, or with the Satlink connected to a dummy load. Otherwise, the transmission may interfere with other stations. The test message that will be sent is displayed in the text box to the left of the send button. Change the message by selecting custom and then changing the message using the ... control.

If the setup has been entered, this dialog will display the Current Message that would be transmitted if a random message were sent. Use the control next to Group to select which random group to see formatted. Along with the message, the dialog displays the number of

characters in the message and the amount of time that would be needed to make the transmissions. These will be useful things to examine to help make sure the set up is correct.

To see the detailed status from the transmitter, press the Status button.

Pressing the “Reset” button will send a command to the Satlink to reset (reboot). This might be necessary in the rare case where the Satlink has a problem that can only be cleared by reset, but no one is at the station to cycle power.

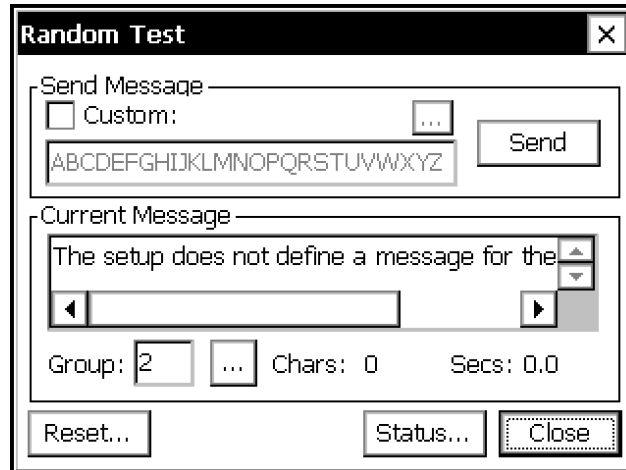

### Satlink Status

Satlink keeps a detailed status of its present and past operations. The Xpert will display this information in the Satlink Status dialog.

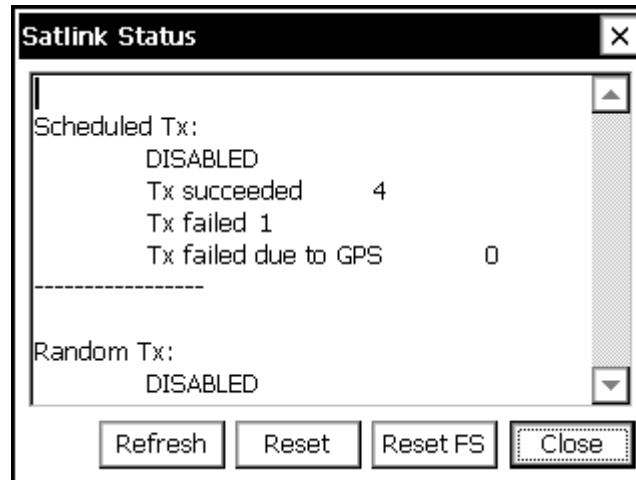

The *Refresh* button is used to update the status data displayed. The *Reset* button is used to command Satlink to reset its status counters. The *Reset FS* button is used to command Satlink to reset its failsafe.

## Self-test

The *Self-test* branch in the Setup tab is used to manage the self-test routines built into the software. Self-test runs either at startup or when the RUN button is pressed in the dialog. When it runs, a file named test\_results.txt is created as a place to preserve the test results. As long as this file exists in \flash disk, the self-test routines will run each time the system starts and will continue running until stopped by the user.

The self-test routines prompt for user input or acknowledgment at several points in the test. If there is no user input, the tests will repeat automatically. At the end of each test cycle, the system prompts to repeat the tests or exit. The user is also given a chance to delete the test results file, which will prevent the tests from being run again on the next system start.

The following test are performed each time SelfTest executes:

- Power Consumption: provides opportunity for user to measure power consumption while the system is in its deepest sleep.
- Verify Physical Memory: verifies the correct amount of memory is present.
- Verify Flash Disk: verifies the correct amount of storage memory is present.
- Verify Watch Dog: verifies the watch dog timer counter is counting within range.
- Verify Decoder/IOCS16: verifies Decoder/IOCS16 operation.
- Verify Data Bus to Latch: verifies address and data bus operation.
- Verify COM ports: verifies com port operation.
- Verify I2C Devices: verifies expected I2C devices are present (test on Xpert requires presence of at least one I/O module to pass).
- Verify PCMCIA: verifies read and write to PCMCIA storage card, when present.
- Verify Display Buttons: verifies the operation of the display module buttons (Xlite only).
- Verify Battery Voltage: verifies battery voltage is 12V +/- 2V.
- Verify Xlite I/O: verifies I/O module functions (Xlite only).

Pressing the *Edit* button with the SelfTest branch selected brings up the following dialog that controls what optional tests are to be run.

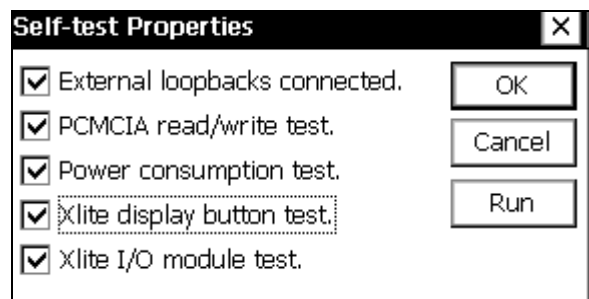

External loopbacks connected – The system expects the following:

- Null modem cable connecting COM2 and COM3.
- Null modem cable connecting COM6 and COM7 (if present).
- Null modem cable connecting COM8 and COM9 (if present).
- External loopback connector on COM4, which connects RTS to CTS, DTR to DSR, and Tx to Rx (Xpert only).

PCMCIA read/write test – Make sure a PCMCIA card is inserted to pass this test.

Power consumption test – All test runs begin with this test. The system puts itself into deep sleep for 1 minute so that the user can measure power consumption.

Xlite display button & I/O module tests: Xlite only.

## Setup File

The *Setup File* branch in the setup tab is used to manage the setup file containing the system setup and configuration. The setup file contains all of the system's settings except for station name, Xpert display contrast settings, and log export historical data.

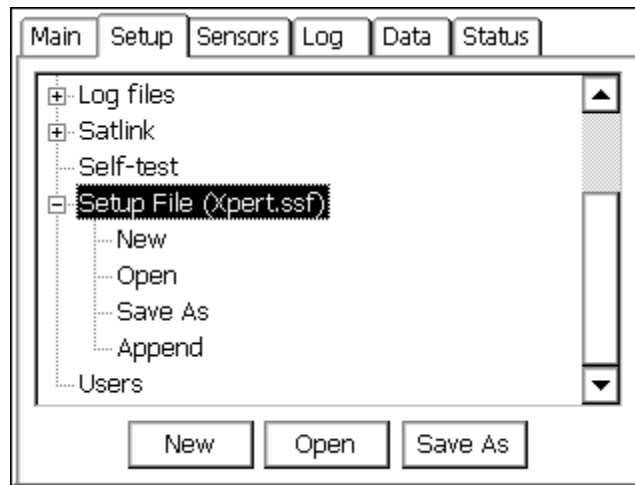

### New

The *New* option is used to reset all settings to a default state with a name specified by the user. After selecting *New*, the system prompts for the name of the new setup file. If the file specified exists, the system warns that it will be overwritten.

### Open

The *Open* option is used to open existing setup files.

### Save As

The *Save As* option is used to save current settings to a file with a different name. A large number of setups can be stored, limited only by the available Flash memory. To save a setup under a new name, select the *Save As* and click *Edit*. The following window will appear:

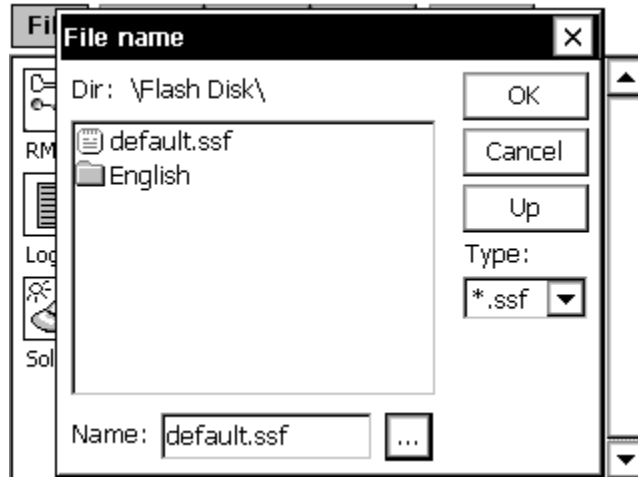

The *Up* button is used to move up one level in the directory tree structure. Use it to get to the PCMCIA ATA flash disk card, which will be displayed as “\Storage Card\”. To change the filename for the setup file being saved, click the change button (“...”) and using the virtual keypad to enter the desired name of the file.

## Append

The *Append* option is used to append blocks from another setup file to the current one. Note that only blocks are appended. No other settings from the setup file selected are imported (e.g., Satlink settings remain unchanged after appending a new setup file).

Note: The system saves the setup file as changes are made so that it is never necessary to perform an explicit save (and, hence, there is no *Save* option).

## Users

The *Users* branch of the setup tab is used to manage the list of user login accounts to the system. Pressing *Edit* with this branch selected brings up a window with all the users accounts that have been added so far (it will be blank if none have yet been added.) From here, an account can be added, modified or deleted.

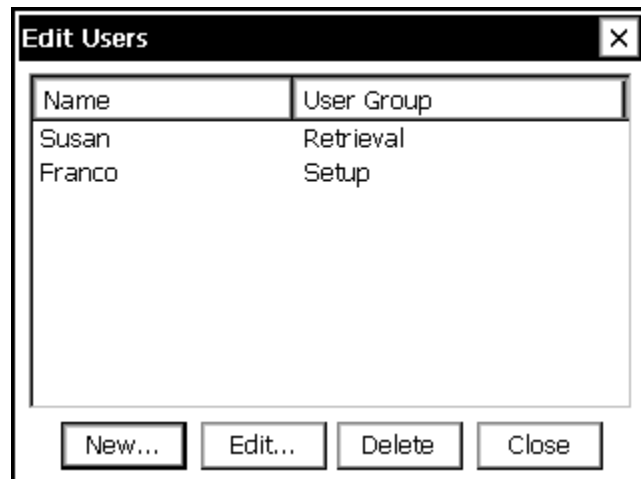

Pressing *New...* or *Edit...* brings up a user properties window. This window has blanks for user name, password, and access level (retrieval or setup). If no password is desired for that user, simply leave the password spaces blank.

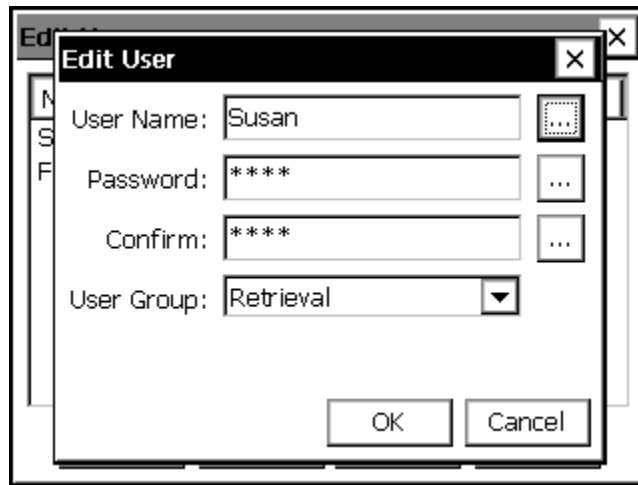

## SENSORS TAB

---

The Sensors tab shows all the sensors that have been added to the system, the sensor addresses, the last data value sampled from each sensor, and the quality of these last sampled values. The page is automatically refreshed every 5 seconds. Note that just because a sensor has been physically attached to the system does not mean the system software is aware it is there. Adding a new sensor or other input to the system is done through the *Setup* tab.

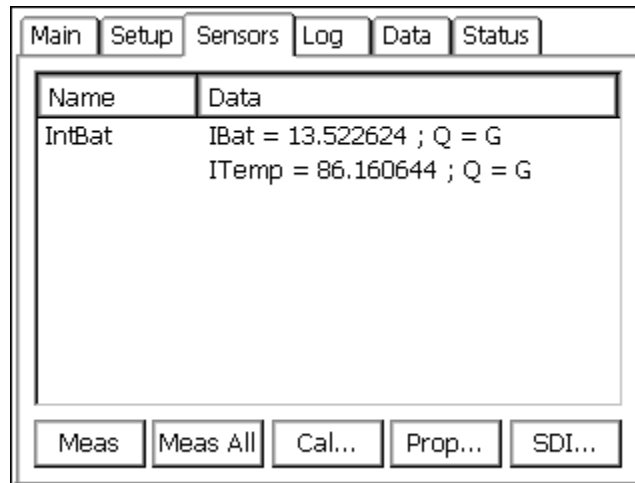

### Live Measurements

To get a live reading from any of the sensors, first select that sensor in the Sensors window and then press the *Meas* button. To get a live reading from all the sensors, press *Meas All*. Regularly scheduled sampling always gets priority over live readings, which might result in a live reading taking several seconds to be returned.

Note: If recording is not on, then attached I/O modules have not necessarily been initialized. As such, measurements may not be accurate.

### Calibration Sequences

The Calibrate button runs a calibration sequence on the selected sensor if one had been previously setup. The calibration procedure writes a message to the log to document any change that is made. [See SETUP BLOCKS/*sensor* descriptions to determine if a calibration method exists]

### Properties

The *Prop...* button brings up the properties page for the selected sensor. This allows sensor values to be changed without having to go to *Setup* (note, however, settings cannot be changed without turning recording off).

## Sending SDI-12 Commands

The *SDI...* button brings up a window that can be used to send commands and view responses from any SDI-12 sensor attached to the system, as shown below. Note that sampling from all sensors will be stopped while in this window.

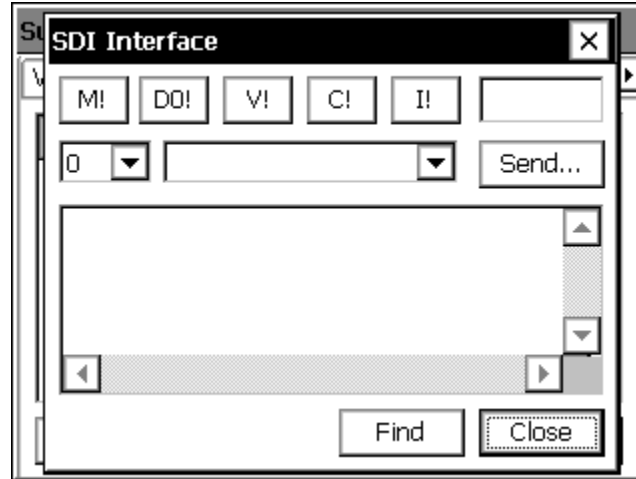

The SDI-12 window has a box for selecting the address of the device to communicate with and also a *Send* button that allows you to create SDI-12 messages. There is also a drop-down menu with the last 5 commands to select and send one of the last commands that were issued. The larger text box displays the history of the previous commands and replies from SDI-12 communication.

The SDI window has some shortcut buttons for sending the most common commands. These commands are M (measure), D0 (data), I (information), V (verify) and C.

A timer runs whenever a response is received on SDI-12. This timer is displayed and shows the number of seconds that have elapsed since the last response. The user can use this timer to know when to issue D commands in the event that the SDI-12 device requires a long time to perform the measurement or function. The user may also monitor the text box for the sensor's service request prompt.

This window also has a *Find* button. Pressing it will cause the Xpert to cycle through all SDI addresses and display any sensors it finds. A count of the number of sensors found will be displayed as the operation progresses. The find may take ten seconds to run as there are over sixty SDI-12 addresses to check. When the unit finds a sensor, it will issue the I (identification) command and show the results of the I command in the command history text box.

When more than one SDI port is available (e.g., when using the optional SLL "RS485SDI.sll"), the window contains a *Port...* button that can be used to select the active SDI port.

When exiting the SDI window, the software will prompt to see if Recording should be restarted if it was stopped on entry.

## DATA TAB

---

The Data tab shows all the data values in the Xpert that have been tagged with either a Coms Tag or FieldVar setup block. If this window is empty, it means that neither Coms Tags nor FieldVars were used in the setup. The data in this window are the values that will be transmitted in response to a request for current data. If the data results from a Coms Tag, and the tag block is connected to an Alarm block, the Alarm status will show up under the column labeled “Alarm”.

This window provides three controls: *Refresh*, *Measure* and *Change*. *Refresh* updates the window with the latest information. When the current selection is a Coms Tag, *Measure* causes the system to make a live reading of the sensor to which the Coms Tag is connected (see Note below), and *Change* alters the current value for the value that is displayed (*Change* will also kickback the value to blocks to which it is connected, e.g., if a Coms Tag is connected to a Constant Block, you can use change to alter the value of the constant). When the current selection is a FieldVar, *Measure* has no effect and *Change* changes the value of the displayed property.

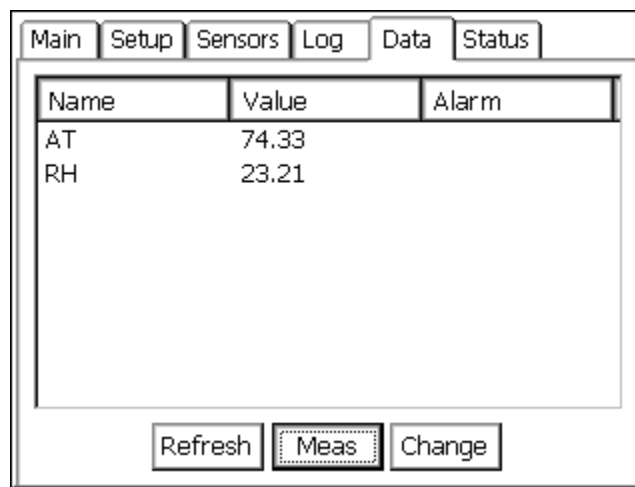

Note: Coms Tag blocks can only “measure” sensors with which they are inline, if there are no “active” blocks between the Coms Tag and sensor block. Generally speaking, this means the Coms Tag must be connected after the sensor block, and **before** any Measure, Average, or other active block (an “active” block is one that initiates a measurement, and typically has a darkened border in the graphical setup).

The FieldVar setup block, in conjunction with the Data tab, provides a way to access often-changed properties from multiple blocks in the setup in one convenient place. To understand FieldVars, some knowledge of the way the Xpert is set up is needed. The graphical setup is discussed in detail in the next chapter, but for the purposes of this discussion, let’s look at a sample setup screen:

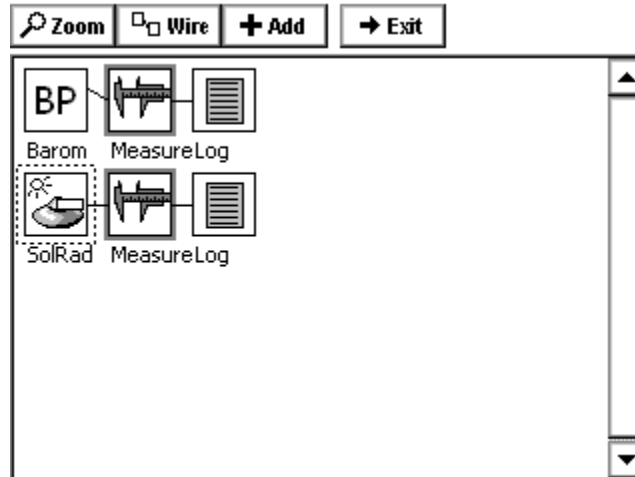

Each block in the Xpert setup represents something different. In the above setup, the solar radiation (SR) and barometric pressure (BP) blocks represent physical sensors, the measure blocks represents processing operations where the data is being regularly sampled, and the log blocks represent the files in which data is being stored. Data can be thought of as flowing from the left side of the screen to the right.

Each setup block has a properties window that is used to view or change its properties. These windows are brought up by clicking an icon and then selecting *Edit Properties* from the menu that pops up. The properties window for the Measure blocks looks like this:

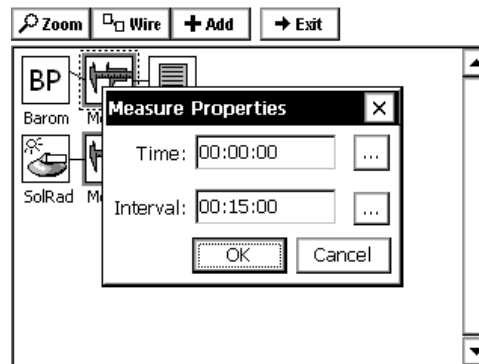

Note the  button next to the data fields, pressing this button will bring up another data entry box that will provide some data error checking that would not be available if data was entered directly into the field. It is recommended to always use the button before entering data.

Let's say we plan to change the sampling intervals for the SR and BP sensor fairly often, and don't want to go into the setup each time we want to change them. Or, perhaps, we want to give technicians that do not have access to the setup screen the ability to change these two intervals. These are cases where it makes sense to use FieldVar blocks.

Using the Add button in the Setup screen (described in the next chapter) we have now attached a FieldVar block to each measure block:

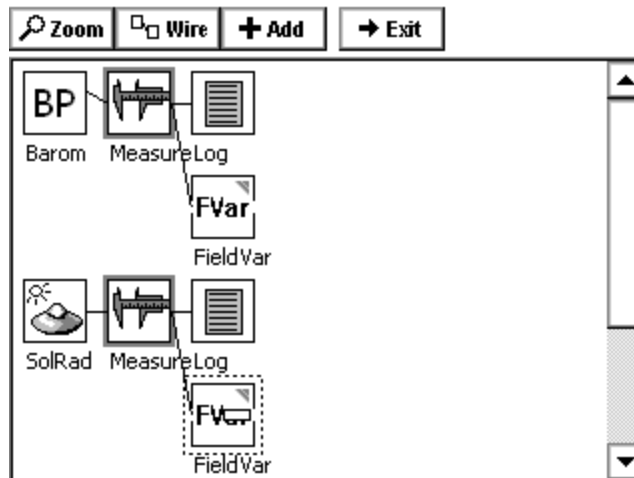

The properties window for either of these FieldVar blocks looks like this:

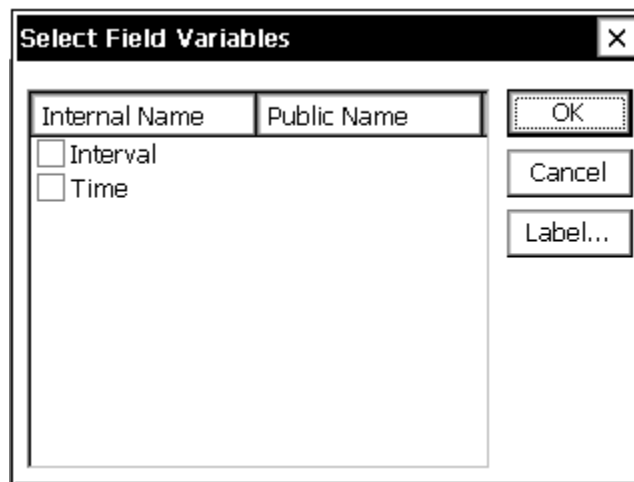

Listed are the two modifiable properties for the Measure block. To add *Interval* to our View Data tab, check the box next to *Interval*. Then click on the word *Interval* to select it and click *Label...* to give this property a *Public Name*. For this example, assign the name “BP Interval”. *Public Name* must be unique in the system in order to uniquely identify the referenced property. If no *Public Name* is specified, it defaults to *Internal Name* when OK is pressed, but will display an error if that name is not unique. To continue this example, click OK and then follow the same procedure with the other Measure block to assign its interval a *Public Name* of “SR Interval”.

Now when we exit the Setup screen and go back to the Data tab, we see the two interval properties for our measure blocks as shown below:

Main	Setup	Sensors	Log	Data	Status
Name	Value	Alarm			
BP INTERVAL	00:15:00				
SR INTERVAL	00:15:00				
<input type="button" value="Refresh"/> <input type="button" value="Meas"/> <input type="button" value="Change"/>					

To change either property, simply select the one to modify and click *Change...* to enter a new value.

## LOG TAB

---

The Log window is used to display data from a log file. The Xpert can support logging to many different log files at one time. A log file can be viewed even if it is open and being logged to.

The Log tab is meant mainly to allow viewing of small sections of the log in order to validate sampling or to view recent values. To view large sections of the log or to perform data analysis, the log file should be retrieved from the unit. This is done using the *Export* button.

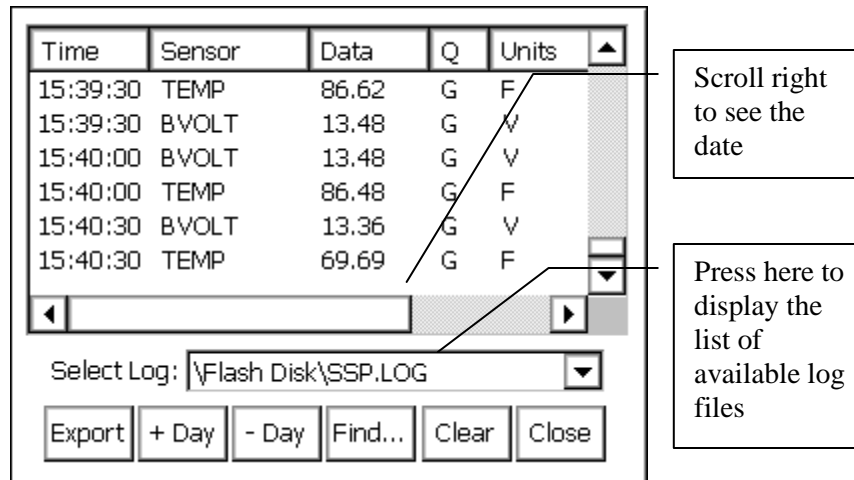

### Column Labels

#### Time

This is the timestamp for the data in the log. This time is normally the time when the data was measured. In the case of an average, the time will be the time of the last measurement. In other cases, the time will be the time the computation was completed.

#### Sensor

This is the name of the sensor/signal that the logged value came from. These names are user-entered in the properties window of each log block in the *Setup* tab. These should have unique names so that a charting or analysis programs can treat the values differently.

#### Data

This is the value of the data point. The value is shown with a user-defined number of digits to the right of the decimal point. The user can set this precision in the properties window of each log block in the *Setup*.

#### Q

This is an indication of the quality of the data. It is set to G (good) or B (bad) by the input module making the measurement. Other modules processing the data can also modify this quality.

## Units

These are the units for the measurement. The units are generally set by the Sensor block (in the Setup Diagram), but can sometimes be determined by a Processing block.

## Date

This is the date for the timestamp. It is displayed in the format selected by Set Date/Time in the Main tab. Because of the small screen size, the column for the date is hidden. Use the scroll bar to see the date.

## Selecting Log File

Use the pull down menu next to *Select Log* to show all the log files in the system that are available for viewing. Log files are created, modified and deleted under the *Setup* tab. To change what sensor data gets directed to a certain log, the properties for that log must be modified in the *Setup* screen.

## Navigating the Log

The log file can be navigated either with the scroll bars on the sides of the Log window or with the buttons at the bottom of the display.

### +Day, -Day

The buttons *+Day* and *-Day* can be used to jump ahead or back one day's worth of data.

### Find...

The *Find...* button can be used to search for the data logged near a certain date and time.

## Clearing the Log

Pressing this button causes contents of the log file to be erased. The system will ask for confirmation before doing this. Note that this erases the contents of the log file but does not delete the log file itself – this can only be done under the *Setup* tab. Data will continue to be stored to a cleared log file if logging to that file is active as defined in the *Setup*.

## Export

This button is used to retrieve the log file. Clicking this button will cause the system to lead you through the steps to create an ASCII file of the data in the log. The log file is a compressed file. If you were to try to view the file, you would see gibberish because of the compression. Converting the file to ASCII allows the contents of the file to be viewed.

As a part of this Export process, you are asked to specify a destination for the file. If you do not get a prompt to save the file on the PC, you should change the directory for the file to be `\Temp`. To do this, press the button labeled *Up* and then select *Temp*. If you were to select `\flash disk\` as the destination directory, you could fill the flash disk with the new file and shut down the system.

If you purchased a PCMCIA ATA flash card for data retrieval, you may install it into the system, and, when you press the button labeled *UP*, you will see Storage card as an option.

This folder is the PCMCIA card. This is also where the Dump Data menu from the front panel menu will look to export files.

When you press the Export button, the following dialog is displayed:

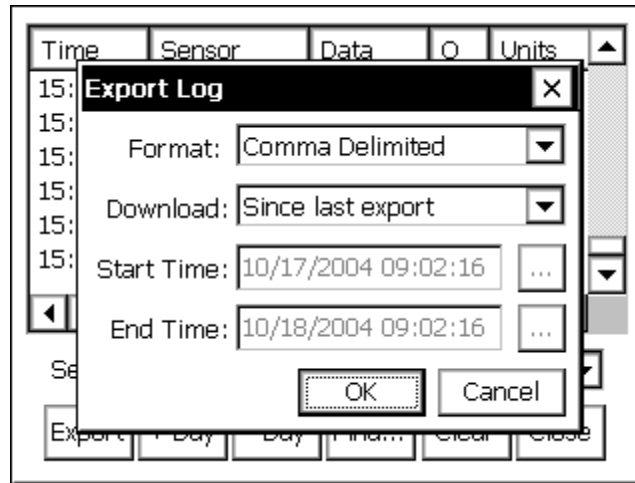

This dialog allows you to define what the exported log file should look like.

The *Format* options are: Comma delimited, Tab delimited and Fixed Column. The comma delimited format works well with spreadsheets. The Tab Delimited and Fixed Column formats can work well when printing.

The *Download* options are defined as follows:

- Since last export - When this option is selected, the system exports only data that is more than the time of the last log export. If the log has never been exported, the system exports the entire log.
- Start time to end time - When this option is selected, the system exports only the data that has a timestamp between the dates and times specified in *Start Time* and *End Time*.
- Start time to end log - When this option is selected, the system exports only the data that has a timestamp between the time specified in *Start Time* and the end of the log.
- Start log to end time - When this option is selected, the system exports only the data that has a timestamp between the start of the log and the time specified in *End Time*.

If you are using XTerm and press Export, the software will automatically transfer the file to your PC without creating a copy of the file on the Xpert.

## STATUS TAB

---

The status tab displays detailed status information from the Xpert. The data displayed includes the status on each I2C module, any communication modules, and the system in general. To update the status menu, press the *Refresh* button.

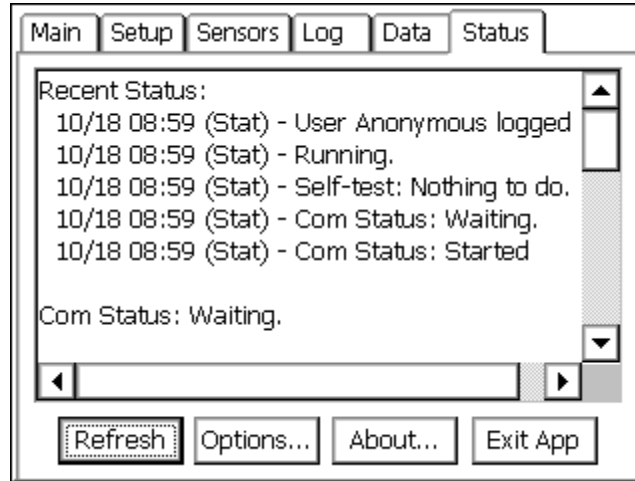

Select the *Options* button to access status reporting options. The Status Options allows the user to configure where status and debug messages should be sent. Note that status messages are automatically stored in the system log.

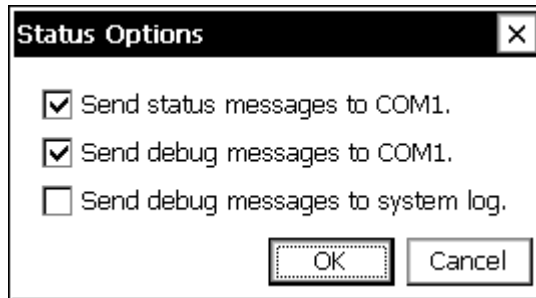

To access the about dialog, press the *About* button. The About dialog displays version and copyright information for the Xpert executable and libraries. This dialog also displays the serial number of the unit.

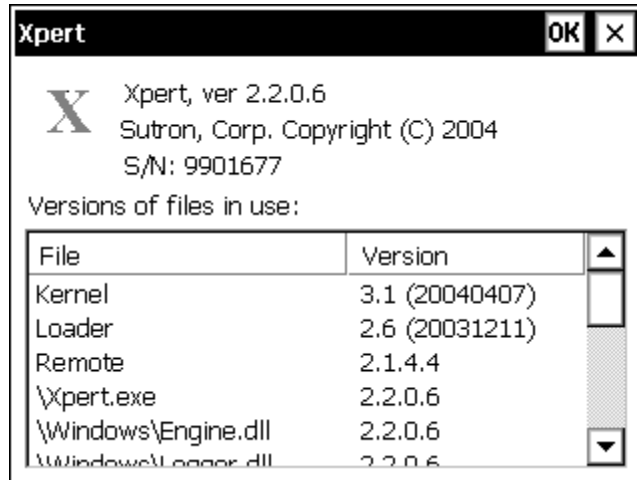

The *Exit App* button is used to stop the Xpert program. Normally this is only done when you want to update the program itself. When the Xpert program is stopped no data collection or recording will take place. The software warns with the message “Warning, this will terminate the Xpert program. All data and setup not in flash will be lost. Are you sure?”

## USING PCMCIA ATA FLASH CARDS

---

Units with PCMCIA slots can use a PCMCIA ATA flash disk card to either expand flash disk space for data logs or to upload/download setups or download log files. Custom applications may add other functionality for the PCMCIA flash disk. See below for description on each application.

Working with the PCMCIA ATA flash disk card is similar to working with the internal \flash disk\ folder. Whenever you specify the location to place files, press the UP button (see below) to see a root directory structure on the XPERT. The PCMCIA card will be shown as the STORAGE CARD folder, double click this entry, and you are working on the PCMCIA card.

Sutron sells a 32MB card part number 8080-0011-32.

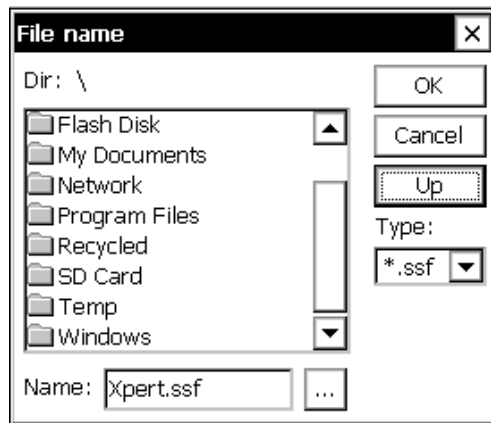

### Expand Log File Capabilities

The PCMCIA ATA flash disk card can be used to increase the amount of log file flash disk space from the built in 4MB (shared) to 32MB.

To do this, follow these steps:

1. Place the card into the PCMCIA slot
2. Go to the *Setup* tab
3. Click LOG, then EDIT
4. Click the NEW button
5. Click the ... button next to filename
6. Click the UP button, and then double click into the \Storage Card\ folder
7. Enter a file name for the log
8. Click the OK button back to the LOG FILE PROPERTIES box
9. Don't forget to increase the size of the log file!
10. Click OK and the log file will be created on the PCMCIA ATA flash disk card

To use the log on the PCMCIA card, select the log file on \Storage Card\ folder from the LOG block properties.

## Upload/Download Setups

Setup files can be stored onto the PCMCIA flash disk just as they are stored on the local flash disk. To do this, follow these steps:

To save the setup from the GUI (Xterm):

1. Place the card into the storage card slot (compact flash cards are internal to the unit)
2. Go to the Setup tab
3. Highlight the Setup File entry and press the Save As button
4. On the right side of the File Name dialog, press the Up button
5. Double click the name of the storage card folder
6. Give the setup a name, or leave it at the default, then click ok.

To open a setup from the GUI (Xterm):

1. Place the card into the storage card slot
2. Go to the Setup tab
3. Expand the Setup File entry, select Open or Append, and press the Edit button
4. On the right side of the File Name dialog, press the Up button
5. Double click the name of the storage card folder
6. Click on the setup name to open or append, and click ok

## Download Log Files

Log files can be retrieved from a unit onto a PCMCIA ATA flash disk card. To do this, follow these steps:

To retrieve the log using the GUI (Xterm):

1. Install the card into the PCMCIA slot
2. Go into the LOG tab
3. Click export, choose a data format, then click OK
4. Click the UP button, and then double click into the \Storage Card\ folder
5. Give the file a name, or use the default,
6. Select the download format, then click OK

# **Chapter 4: Graphical Setup Diagrams**

## OVERVIEW

---

This chapter will discuss the way in which to create and modify graphical setup blocks. Determining when to use the graphical setup versus the Ezsetup measurements is discussed in detail in chapter three, but the simple rule is this: If the sensor is measured, or averaged only, then use EzSetup Measurements, if additional processing is needed, or the data is needed for calculating other parameters, use the graphical setup.

The graphical setup blocks screen is accessed by going into the Setup tab and clicking on either the Graphical Setup tree and clicking EDIT, or by selecting one of the graphical sensors under the Graphical Setup tree and clicking EDIT. Selecting Graphical Setup and clicking EDIT will show all sensors configured in a graphical manor, selecting only one of the graphically setup sensors will show that sensor and all processing related to that sensor only. Some users find that viewing the whole Graphical setup can be overwhelming, therefore it is recommended to only select/create one sensor at a time when setting the system up.

## AN EXAMPLE GRAPHICAL SETUP

Pressing *Edit* with the *Graphical Setup* item highlighted on the *Setup* tab brings up a screen similar to the one shown below. The tabs at the top of the screen have been replaced with the buttons *Zoom*, *Wire*, *Add*, and *Exit*, with the rest of the screen reserved for placing and connecting setup blocks. From this screen, we can get a quick view of where data is coming from, how it is getting sampled and processed, and where it is going. Below, for example, we see:

A parameter from the barometric pressure sensor is being periodically sampled and its maximum or minimum being stored to a log at some rate; and,

Solar radiation is being regularly sampled, logged and periodically transmitted via satellite to a main station.

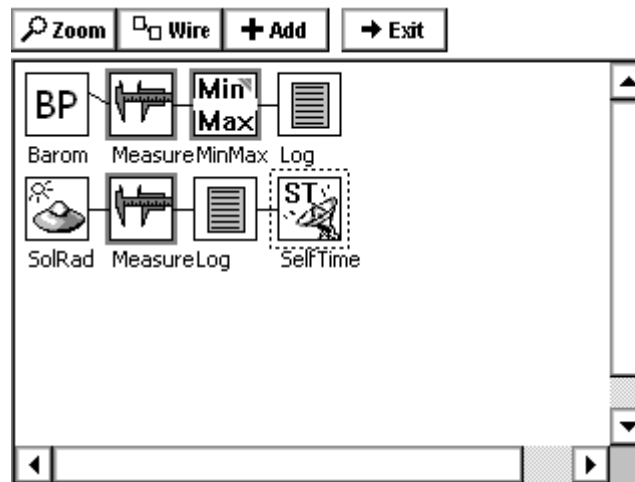

### Block Categories

Setup blocks come in general categories – *Input*, *Processing*, *Logging*, *Telemetry*, *Miscellaneous*, and *Output*. Four of these types of block are represented above. On the left are the *input blocks* representing barometric pressure and solar radiation sensors hooked to the system. Next to them are the *Measure* and *MinMax processing blocks* which request and/or perform operations on the data from the sensor blocks. Note how these two blocks have darkened borders. This is an indication that the block is “active”, i.e., that it initiates data flow through a chain of blocks.

After the the *Measure* and *MinMax* blocks come two *log blocks*, which indicate where the data is being stored. Finally, there is a *telemetry block* which indicates how the data is being transmitted.

Blocks of a certain type are not restricted to a particular column in the display, but data does always flow from the left side of the screen to the right.

## Block Inputs and Outputs

Setup blocks are hooked together via their inputs and outputs. A block with an input can *accept* data from another block and a block with an output can *send* data to another block. To see this more clearly, we'll zoom in on our example using the *Zoom* button on the top of the screen:

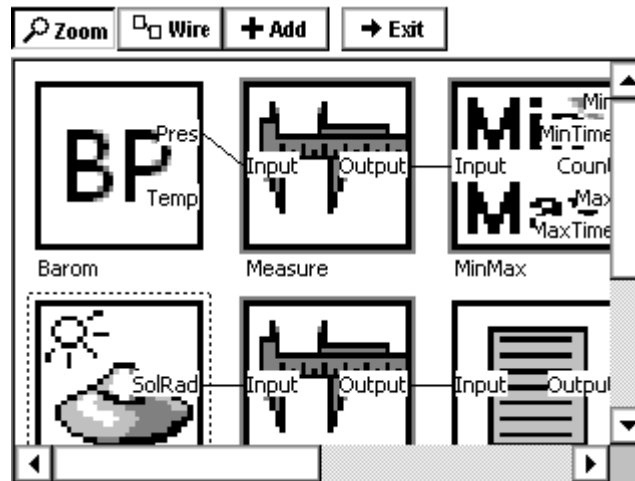

We can now clearly see the inputs and outputs each block has available along with which are being used and which aren't. It is now evident, for example, that only the *pressure* from the BP block is being sampled (not the temperature) and that only the *maximum* value of this pressure is being logged.

## Block Connectability

The Xpert setup was designed for maximum flexibility. The system will allow any two blocks to be connected together as long as the first has an output and second an input. However, this does not necessarily mean that any constructed setup will work. For example, even though the system will allow a sensor block to be hooked directly to a log block, no data will be logged as there is no processing block to request the data from the sensor *unless* the sensor block has an *Event* mode checkbox, in which case it will work.

## Block Properties

We now know a lot about what is happening with our example setup, but not everything. We don't yet know, for example, the units the barometric pressure setup is going to return its data in, or how often the solar radiation is going to be sampled, or what log file either data stream will be saved to. For this information, we need to look at block properties.

To view the property window for a block, click the icon for the block once and then select *Edit Properties* from the menu that appears:

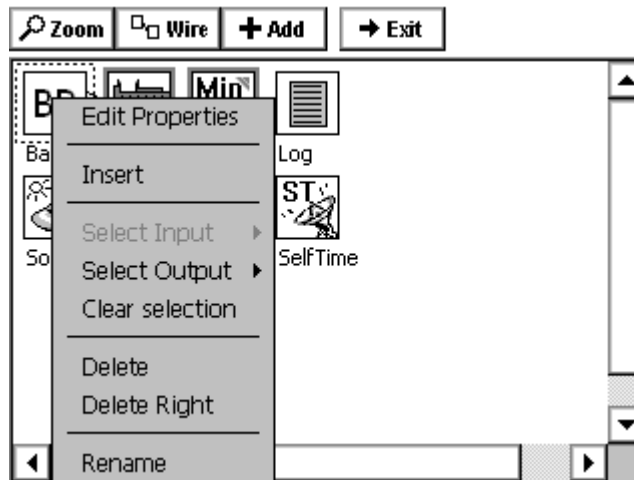

If we do this for the BP sensor block, the following block properties window comes up, revealing the pressure units to be sampled, the SDI address, the averaging time, and the temperature options:

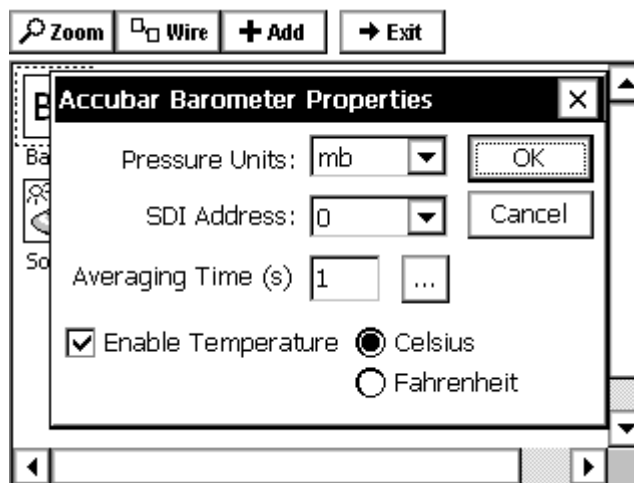

Viewing the property windows for the other blocks in the setup can be viewed in a similar manner. A full description of the properties for each block can be found in Appendix A: Setup Blocks.

## CREATING A NEW SETUP DIAGRAM

---

Now that we have seen an example graphical setup, let's see what it takes to create a small one from scratch. From the Setup tab, highlight [New] and select *Edit*. This will bring up a blank setup screen:

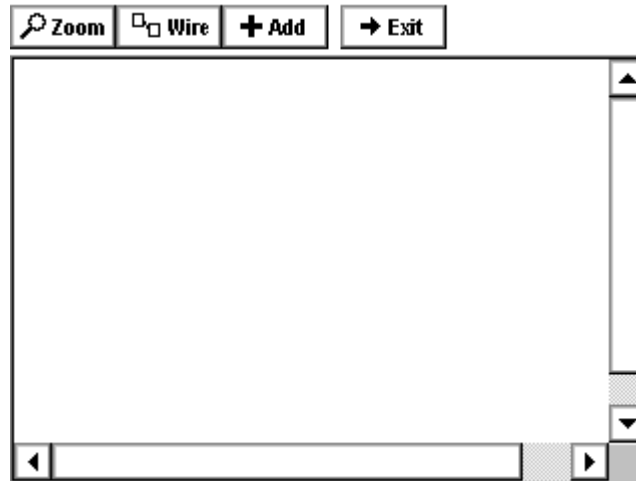

Let's say we've just physically hooked-up two sensors to our Xpert and want to add them to this new setup. One is an RM Young wind sensor, from which we want to log wind speed and wind direction, and the other is a submersible pressure sensor, from which we want to measure water depth.

### Adding a Sensor Using the Wizard

Click the *Add* button to add the first sensor. The following screen will come up:

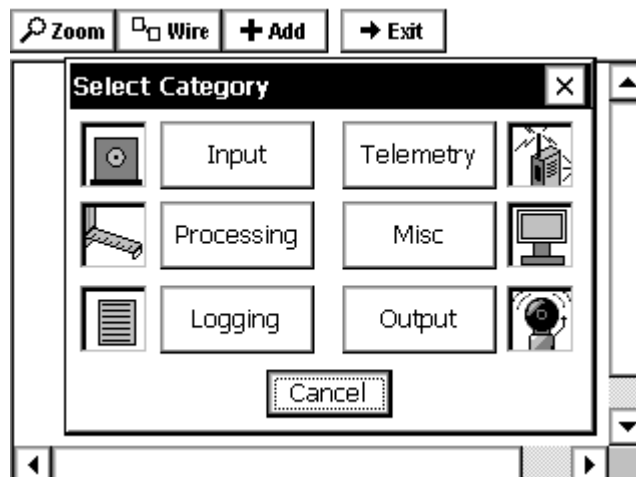

This screen shows the different types of setup blocks. Now click *Input* to bring up a list of the available input blocks:

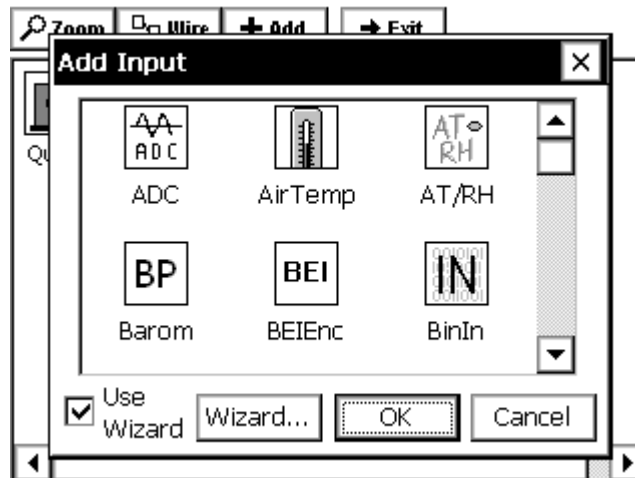

Scroll up or down to find the input block labeled RMYoung. For now, leave the checkbox next to *Use Wizard* checked and click *OK*. Now the main setup display will look like this:

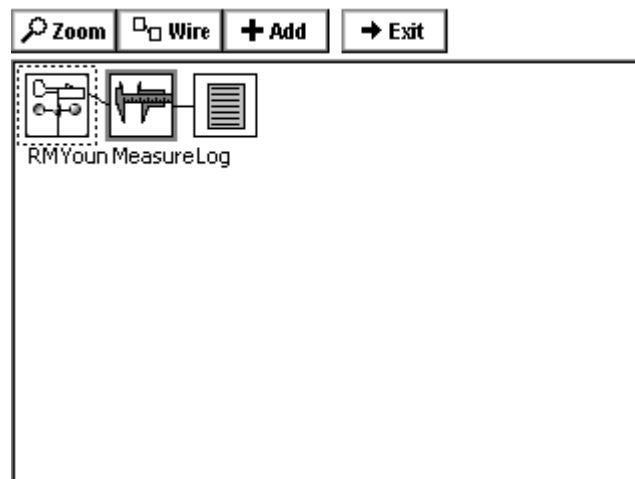

By using the Wizard, we can see that not only has the RMYoung sensor block has been added to the setup screen, but a measure block and log block as well, with connections! The exact blocks that are automatically added with the Wizard are customizable with the *Wizard...* button in the Add Input window above.

## Adding Additional Blocks

Looking carefully, we see that only one of the outputs from the RMYoung block will be sampled and logged with this arrangement. Zooming in on this block indicates it is the wind speed output:

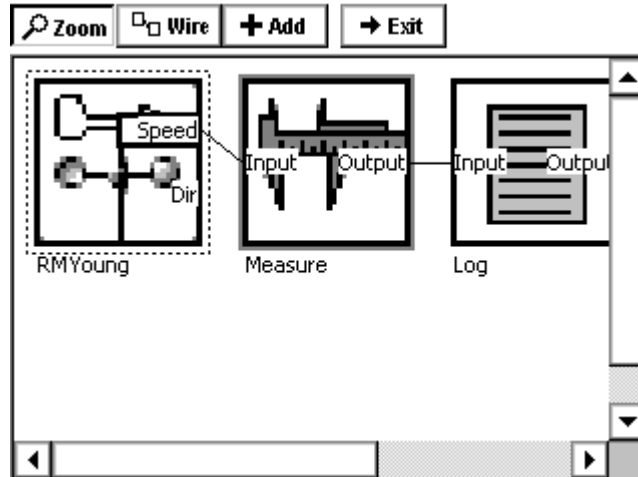

To also sample and log wind speed, we need to create another instance of the measurement and log blocks and connect them to the wind direction output of the RMYoung block. To do this, first: click the RMYoung icon, click *Select Output*, and then (from the slide-out menu) click *Dir* for the direction output:

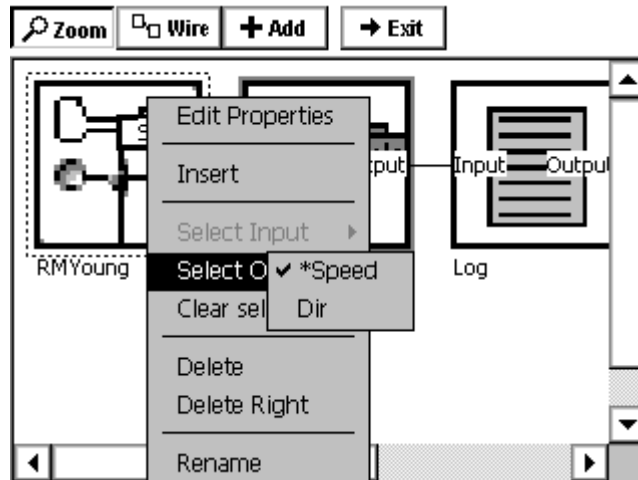

Now click the *Add* button at the top of the screen, click *Processing* to show the processing blocks, select the *Measure* block, and click *OK*. Now we see another measure block has been placed under the first:

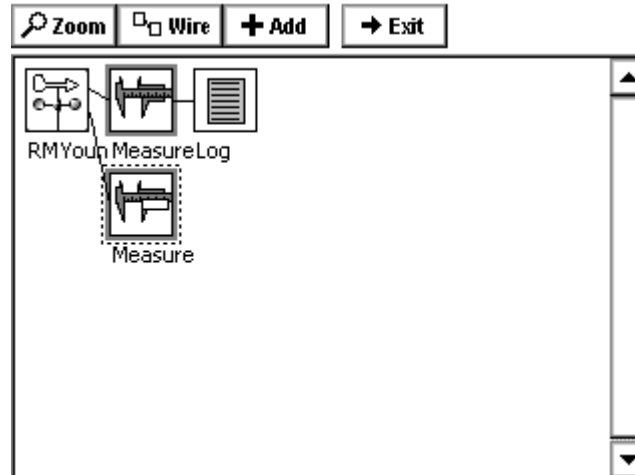

Although it seems as though we would now hook this measure block up the to the log block already placed in the setup, we actually now want to add another log block below the first. This is because a setup blocks input cannot accept a signals from more than one block. However, this results in no loss of functionality as the new log block can be configured to log to the same log file as the previous one.

So, to add this second log block, click the *Add* button, select *Logging* to bring up the logging blocks, select the *Log* block and then click *OK* (we didn't have to select the output from processing as it was already selected from above). Now both of the signals from RMYoung will be sampled and logged:

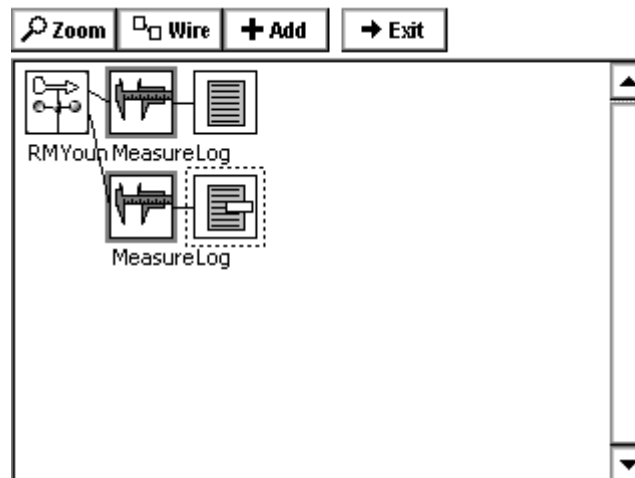

## Changing Block Properties

### Sensor Block Example

Now that all the setup blocks have been placed and the flow of data established, all that is left to do is to change the properties of each block as desired. The properties window of a block can be brought up by clicking the block and then clicking *Edit Properties*. Doing this for the RMYoung sensor block brings up the following window:

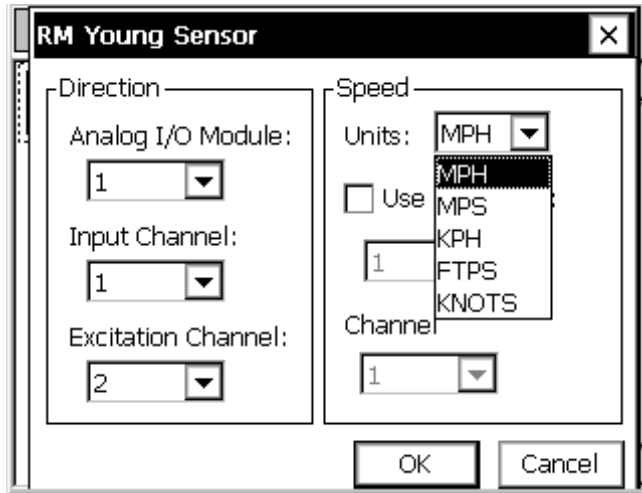

Detailed information on the different fields in this block can be found in Appendix A: Setup Blocks. For now, just change the units to from mph to Knots and click *OK*.

### Processing Block Example

Now click the top measure sensor block and select *Edit Properties*:

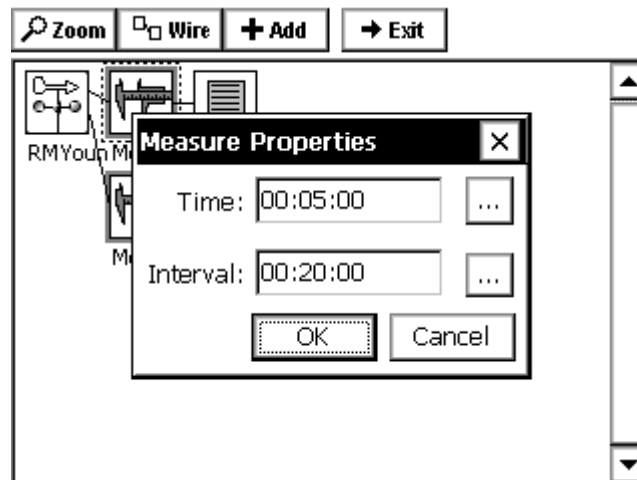

This is where we enter the start time offset and the sampling interval. The measure block is used when samples are desired at a fixed, regular interval. We set up this block to measure wind speed every twenty minutes with a five minute offset from the top of the hour (i.e. at :05:00 :25:00, :45:00 every hour).

### Log Block Example

Finally, click the top the log block to view its properties:

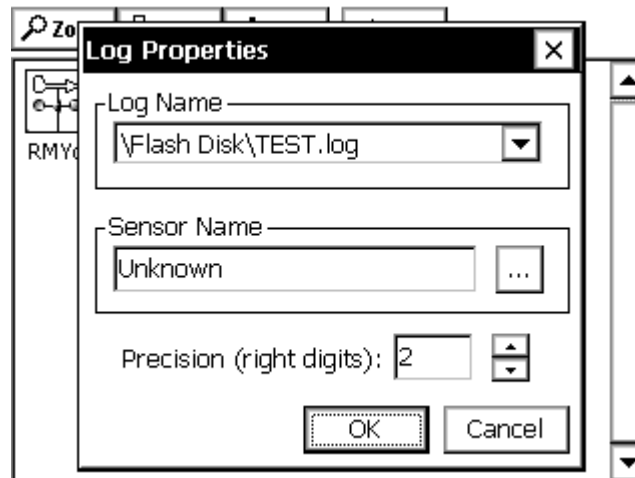

At the top of this properties window is a drop down menu with all the log files that have been created in the system (as well as an option that, when selected, allows you to create a new log file). This drop down box identifies the log to which this setup block will store data.

The default *Sensor Name* can be changed to more easily identify the source of data in the log (this name is used in the Log tab as well as in imported data files). Changing this label is especially important in cases where there are more than one of the same types of sensor.

The *Precision* indicates to what precision the data (wind speed, in our example) will be logged. The value specified should be less than or equal to the sensor's actual precision.

Changing the properties of the other measure block and log block in our setup for sampling and logging wind direction would be done similarly. Full descriptions of purposes and settings for each setup block can be found in Appendix A: Setup Blocks.

### Changing the Block Label

The label displayed underneath the block in the setup diagram can be changed by selecting *Rename* from the pop-up menu that appears after clicking the setup block. Use this to help identify specific blocks in the setup.

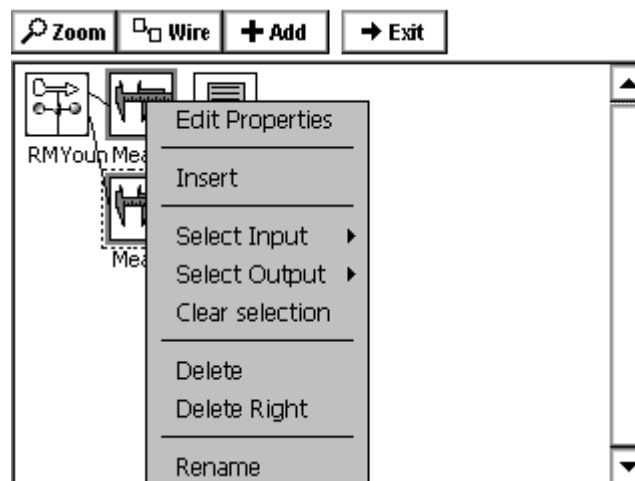

## MODIFYING A GRAPHICAL SETUP

---

### Wiring and Unwiring

The Xpert will attempt to wire blocks together automatically whenever possible. For example, if the output of a Measure processing block is selected and then a log block added, the system will automatically wire them together. However, sometimes blocks need to be wired or unwired manually.

For a simple example of wiring and unwiring, let's say we want to change the setup we have built so far to: 1) add a solar radiation sensor block and 2) hook its output to the second log block instead of the RMYoung wind direction output.

First, we add a solar radiation sensor using the *Add* button (as explained in the previous section) *without* using the Wizard:

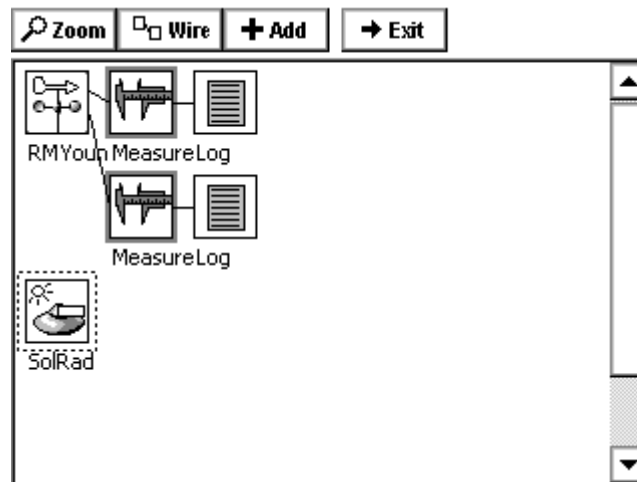

Now we want to unwire the second Measure block. To do this, first click the RMYoung icon and use *Select Output* to select the *Dir(ection)* output. Then click the second Measure block and use *Select Input* to select *Input*. The Setup Diagram will now look like this, with the line connecting the two blocks now in bold:

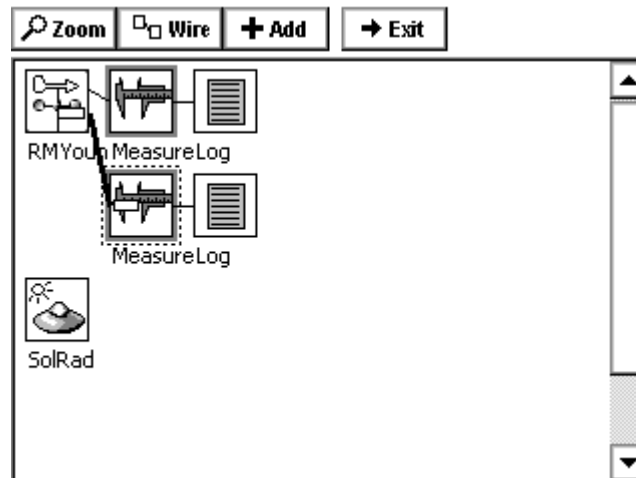

To unhook these two blocks, click the *Wire* button at the top of the screen. The blocks unwired will look like this:

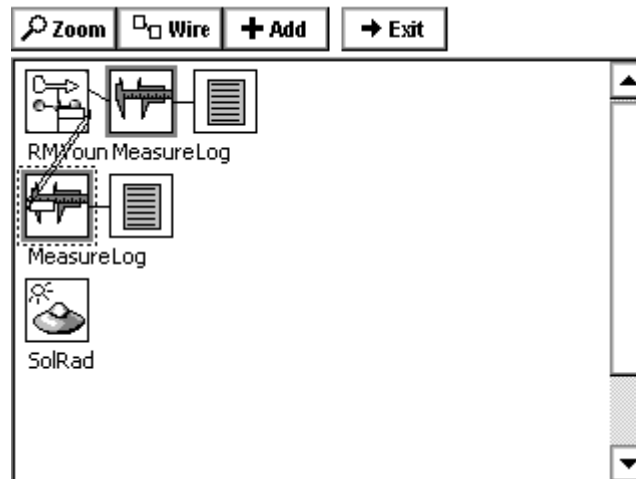

To now hook the measure and log blocks to the new SR sensor we have added, click on the SR icon and use *Select Output* to select its output *SR*:

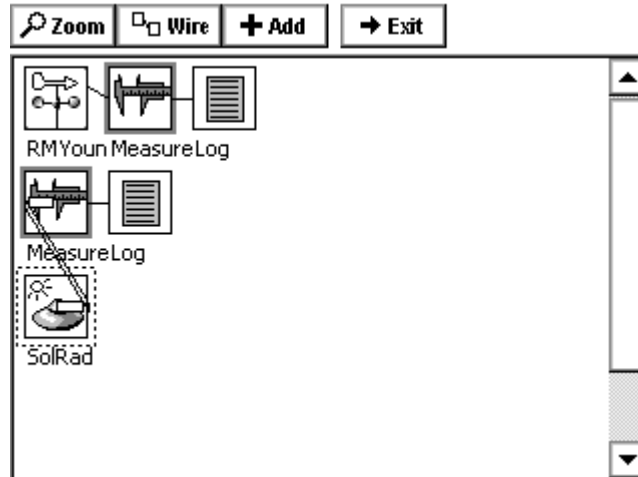

Finally, click the *Wire* button again to get the desired setup:

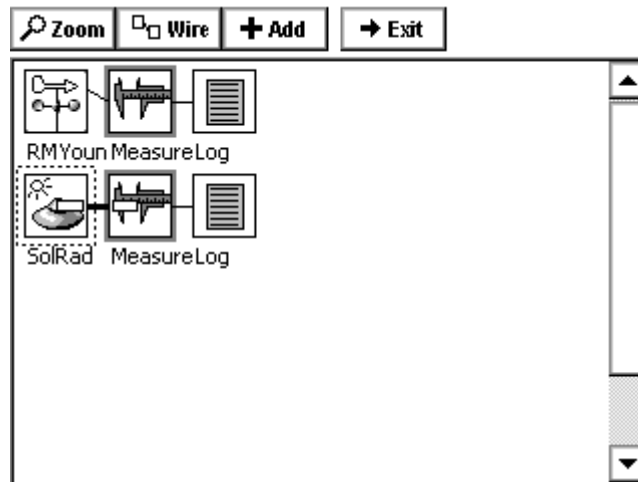

## Deleting a Block

To delete a block, select it and then select *Delete* from the menu that appears. This also deletes the wires coming from that block. For example, if we deleted the second MeasureLog block from above, the resulting Setup Diagram would then look like this:

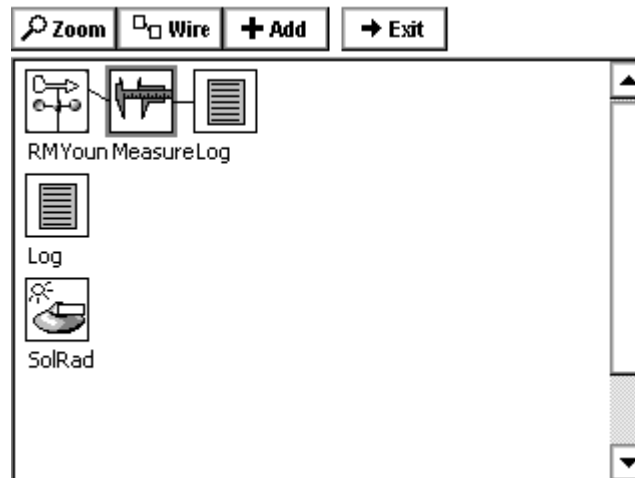

## Deleting Multiple Blocks

To delete multiple blocks, click on the left most block, then select the *Delete Right* menu. All blocks to the right of the selected block will be deleted. In the above blocks, clicking RMYoun and selecting *Delete Right* will delete the RMYoun, Measure and Log with one click.

## Insert A Block

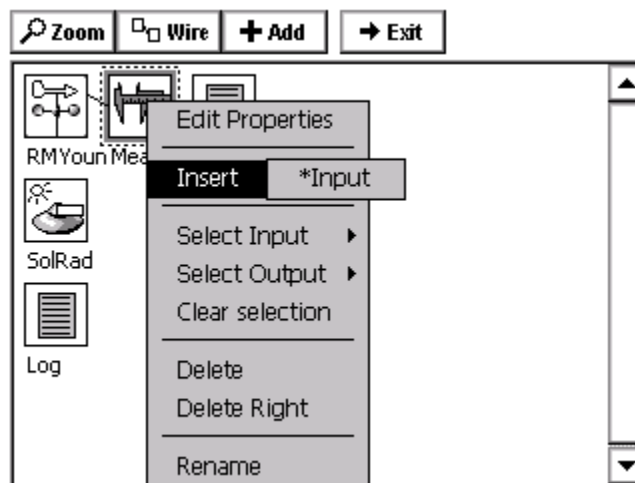

To insert a block into a chain of blocks, simply select a block for the new block to go in front of. So, for the example above, to insert a display block before the measure of the RMYoun, select measure, then insert. Notice the \*Input, if a block with multiple inputs is selected, this would show all available inputs, in the case of measure, only one input is available, so click the \*Input. The Select Category box will be displayed, for this example, select MISC and then select DISPLAY and click OK.

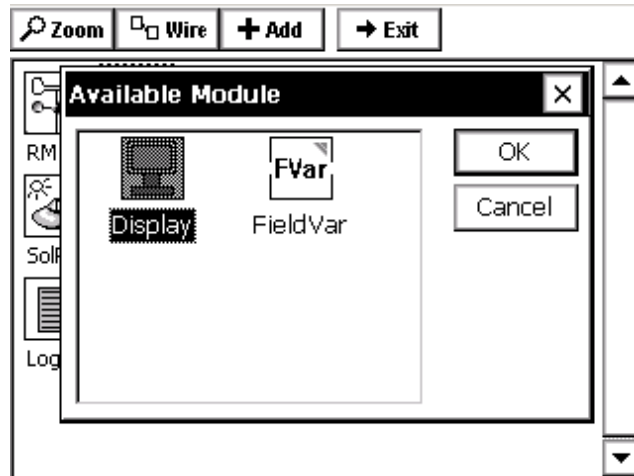

The display is now inserted in front of the measure block.

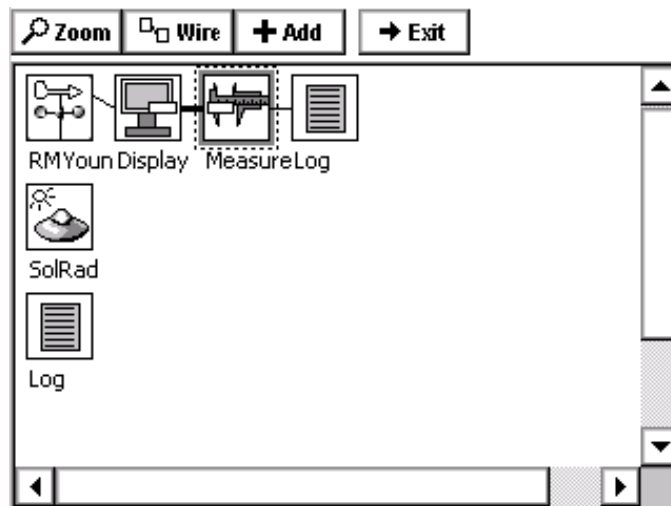

# **CHAPTER 5: EXAMPLE SETUPS**

## EZSETUP STREAM GAUGING STATION

---

Setting up a stream gauging station with a shaft encoder is simple. The following setup will use a 15-minute measurement interval, log the data and transmit it to a GOES satellite.

Connect all equipment before entering the setup. For this example setup, hook a Satlink to COM 2 and a Quadrature shaft encoder to Digital channels 3-4 (terminal B I/O 3 and I/O 4)

Log into the system using the SETUP account access.

Start by setting the station name. This name will identify the station and allow the setup file name to be unique. Do this from the *MAIN Tab* by clicking the three dots next to *Station Name:* and typing or clicking the letters on the virtual keyboard. LakeTop is used in this example.

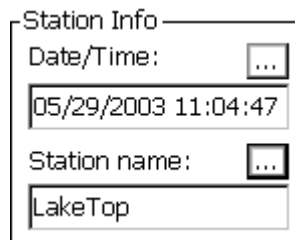

Go to the *Setup Tab*, this is where the rest of the station configuration will take place.

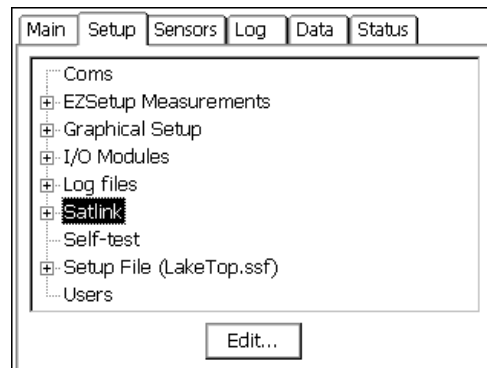

Select the Satlink tree by clicking on it, then, click the *EDIT* button.

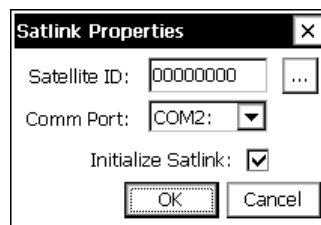

Set the Satellite ID (NESDIS assigned) and COM port Satlink is connected to, and then click *OK*.

If a message saying recording must be turned off appears, click YES, this will stop the system and let the rest of the setup continue. When it asks to restart recording, click NO. Recording doesn't need to start until the entire setup is completed.

Click the plus next to the Satlink tree, then select the Self-Timed branch and click the *EDIT* button. From here, enter all the parameter of the transmission as assigned by NESDIS. For this example, use a 1 hour rate at a 00:00:00 time (offset) and send 8 data values. Also, set the window centering to on and set the window to 15 seconds.

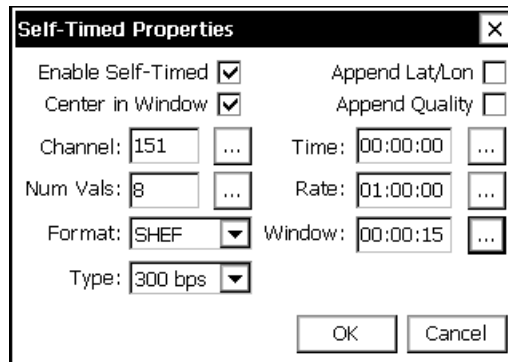

Since this setup is not going to use alarms, no more information is needed for the Satlink setup. If alarms were to be defined, the *RANDOM* tree would be the place to set that information.

Measuring a shaft encoder every 15-minute on a fixed interval is easily accomplished using the new EZSetup tree of the *SETUP Tab*. First, define the measurement interval, then add the sensor and configure it.

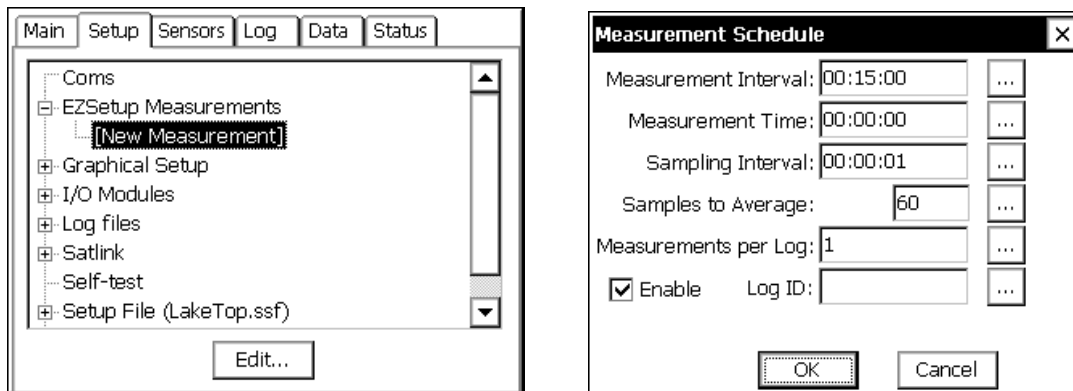

Add the new measurement interval by clicking the plus sign next to EZSetup Measurements, then highlight [New Measurement] and click EDIT.

From here, all parameters for setting up a schedule are shown. For the purpose of this setup, the default values already meet the schedule, so just click OK.

Now that the schedule is defined, a plus sign appears to show that sensors may be added. Click this plus sign to expand the tree, then select [New Sensor] and click EDIT.

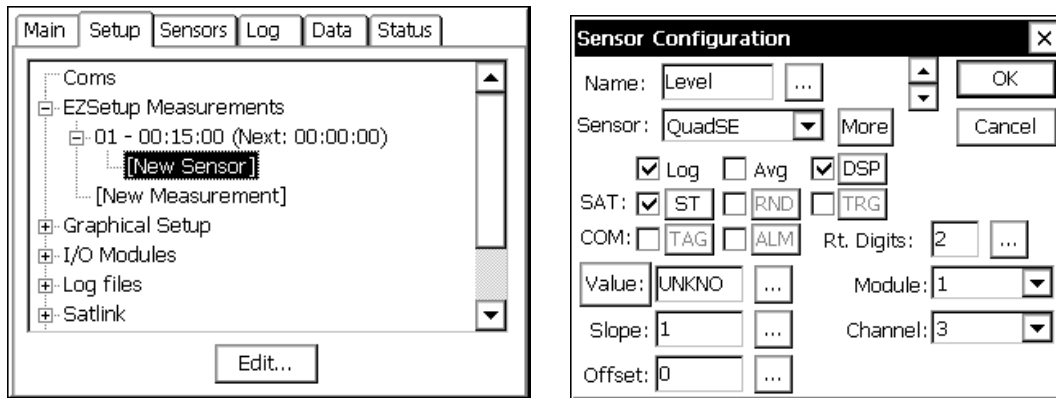

For this example, select a name (Level) select the sensor as a QuadSE, notice the Log and DSP (display on LCD) are already checked, check the ST to send this sensor in a Self Timed transmission, leave default of 2 right digits. Since digital channel one on the built-in digital module cannot be used with a Quadrature shaft encoder, change the channel to 3 (Note: If an external 8080-0002 were used, then channel 1 would be valid).

Click the MORE button to get to the details of the QuadSE properties. See Appendix A to see all the options available for this built-in sensor block. For this setup, leave the defaults.

Click the DSP button to see the properties for the display. It is possible to log a different amount of precision than is displayed on the front panel; the default value used here comes from the Rt. Digits set on the main Sensor Configuration page. For this setup, leave the defaults.

Click the ST button to see the properties for the self-timed transmission. Notice that all the fields are filled in with details previously entered. These details include the Label (From Sensor Configuration), Data Time/Interval (From the EZSetup Measurement schedule), Num Values (From the Self Timed tree under Satlink) and an auto-numbering Sequence (This is the first sensor configured, so it is 1).

Since the transmit format was previously left at the default of SHEF, the Num Values for this sensor are configured here, it is possible to send a different amount of values per sensor. Had BIN-INT (binary interleaved) been selected, this field would display the Num Values set in the Self Timed setup under Satlink tree, but will not allow it to be changed from this properties page. For this setup, leave the defaults.

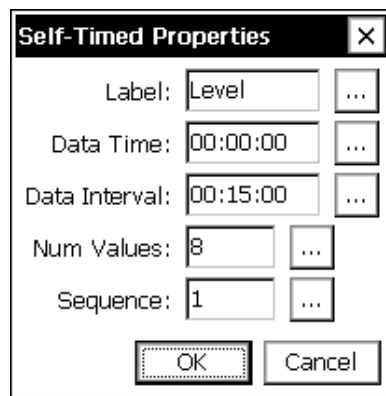

Notice the button labeled [VALUE] and next to it is a box with the letters "UNKNO", this is actually saying "UNKNOWN VALUE" because it has never been measured. Because all the parameters needed to make this measurement have now been configured, press the [VALUE] button to force a live measurement.

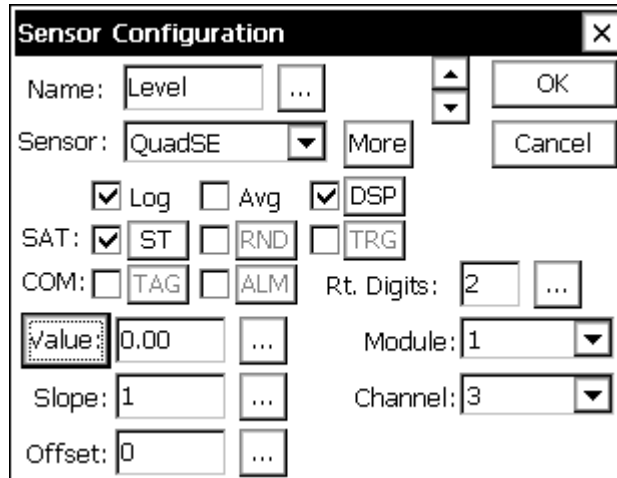

Now, the box is displaying the current value (0.00 in the picture). To set the level to match the actual level (calibration), simply press the three-dot box [...] next to the data, enter the desired reading, and the system now has calculated the offset. Since this example has 0.00 in it, the offset will match what is entered, had the system been running for a while, and had an actual reading, it would have re-calculated the necessary offset automatically. Click OK to save these changes.

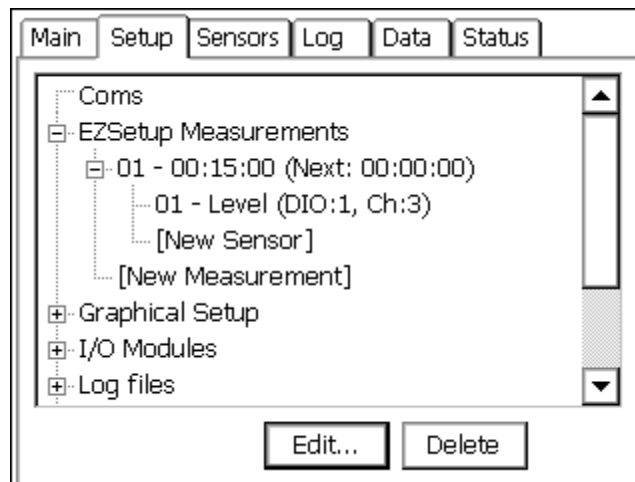

Now the system displays that it has an EZSetup measurement defined, and that a sensor has been placed into that measurement.

Adding more sensors to that measurement is done by selecting the [New Sensor] and repeating the previous steps, selecting the appropriate sensor type, IO module, Channel , etc.

Creating an additional EZSetup measurement, to add hourly averages for example, is done by selecting [New Measurement] and repeating the previous steps, including adding what sensors to measure by this new schedule.

REMEMBER, defining a schedule does no good without defining the sensors below it. So, to add an hourly average of the QuadSE sensor previously setup on the fifteen-minute interval:

Define a new EZSetup measurement, this time setup the Measurement interval to hourly, set the sampling interval to the desired time, and set the number of samples (If one minute interval is used, number of samples could be set to 60 to take samples for the whole hour)

Add a new sensor with the same IO module and channel as previously defined to get the data from the same shaft encoder.

Check the box labeled AVG on the Sensor Configuration screen.

Once the setup is completed, go to the main tab and press START recording.

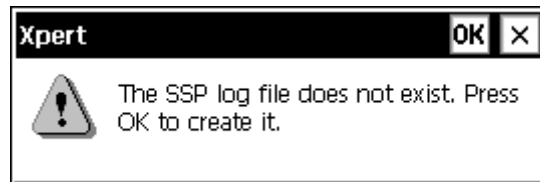

Before leaving the setup tab, a special log file must be created, SSP.log, it is only 'special' because this is where EZSetup places all sensors and this is where communications interfaces look to get 'TAG' data. Had this log file been created already, this warning message would not have appeared. Since the system has detected this log file does not exist it has asked to create one. For this example setup, click OK, and create the default size SSP.LOG file for now. See Chapter 3 - Log Files for more details on this.

Now, that the SSP.log file is created, go to the MAIN tab and press START recording.

That's it! The system is recording data and is going to transmit it on the GOES transmitter.

## GRAPHICAL SETUP TO COMPUTE DAILY MIN/MAX

For this example, a 0-5 VDC level sensor, with a 10ft range is used. The last measured value, daily minimum, maximum, time of minimum and time of maximum are displayed on the front LCD and logged. It is a good idea to first draw out in a notebook the desired flow of data, at first simply write down what data needs collected and if it is just logged, or displayed, or both. Then, look through the manual, if an input block exists to make the measurement, use it, if not, find a generic input block (VDC for voltages).

In this example, the data also needs to be processed for daily minimum/maximums. So a special block is needed, this block has already been defined and is provided in the default Xpert library, had it not been included, it would need to be developed, either by Sutron, or by using the software development kit.

Once the measurements have been defined, and the associated blocks needed to do the measurements have been identified, it is time to start building the setup. Below is the result of building the Graphical setup, block-by-block, starting at the left. This was done without the use of the wizard, since multiple outputs and blocks were needed.

Here is the graphical setup:

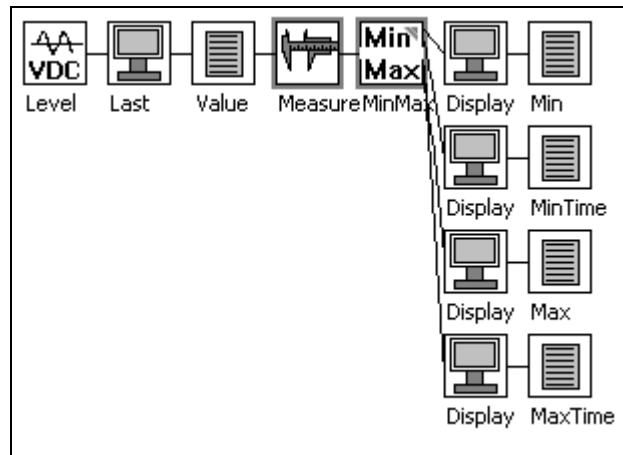

It may look complicated at first, but by looking at it piece by piece it will make sense.

Note that in the graphical setup, data is flowing from left to right. So in the above example: At the far left is where the data is connected, an analog channel measured by a VDC block. Next is a display block, this tells the system to display all data that passes through this point (last measured value in this case).

Not only is the data displayed, but it is also logged by placing a log block directly after the display. The log could be placed before the display, but anytime a measurement is forced from the front panel, it would be logged.

Next, is the measure block. This tells the system how often to take readings.

Directly after the measure is the MIN/MAX block. This block also has a schedule that tells the system how often it should compute minimums and maximums (every 24 hours starting at midnight in this example).

The rest of the blocks are wired to the output of the MIN/MAX block. The values are displayed on the LCD and logged. The only output not wired, is the *COUNT* output, this output tells the number of samples used for calculations and was not needed for this setup.

Notice the blocks have been renamed, renaming the blocks will help in maintaining the setup by making it easier to read.

In this example, no satellite transmissions have been defined. Adding transmission parameters is easy. Simply select the output data to transmit by selecting a point (typically a log block) and selecting its output. Then add a self-timed parameter or random trigger block as needed.

Unlike the EZSetup, every block in the Graphical setup must have the parameters defined separately. EZSetup will pass through many of the parameters from one screen to another, because all data is maintained and entered in a specific order. In the Graphical setup, the order of the blocks is not known, and, in some cases, one output may go to several other blocks. For example, in the EZSetup, the label of the sensor is passed into the display parameters for the label of the LCD. In the graphical setup, the label (level) would not make any sense if it were passed into all the blocks that followed it, because additional processing was done to get computed values that are no longer just the level.

# **Chapter 6: Operation with a PC running XTerm**

## INTRODUCTION

---

Sutron has designed the Xpert so that a Windows-based personal computer (PC) running its XTerm program can setup and operate an Xpert without using the front panel. This is a necessity for Xperts that do not have a touch screen display. XTerm supports several connection methods and so can be used to access remote Xperts, e.g., those connected by modem. This section describes how to use XTerm to communicate with an Xpert.

Sutron provides two versions of XTerm. One version is intended for desktop PCs running Microsoft Windows. The other version is intended for PocketPC devices like the HP iPaq and Dell Axim. The two programs perform essentially the same functions, with the biggest difference being that XTerm for the PocketPC displays the Xpert screen rotated 90 degrees. XTerm does this because the aspect ratio of the PocketPC screen is the same as the Xperts except rotated. This ensures the user can see the Xpert screen with maximum resolution.

### Installing XTerm

There is no special installation needed for XTerm on a desktop PC. Simply copy it to any folder on your PC.

Always make sure you have the latest version of XTerm, which can be downloaded from Sutron's website. The version of XTerm on your PC can be found by selecting "About XTerm..." in the XTerm System menu, which is accessed by clicking the "X" in the upper left menu bar.



To install XTerm on a PocketPC, run its installation program from a desktop PC that already has ActiveSync 3.1+ installed (this is a Microsoft program that is typically supplied by the vender of your PocketPC device, and is typically installed as part of the software that comes with the PocketPC. At the time of this writing, ActiveSync may be downloaded from <http://www.microsoft.com/mobile/pocketpc/downloads/activesync35.asp>).

When you start XTerm, the following screen is displayed to allow you to specify and configure the type of communication link that exists between XTerm and Xpert (desktop PC shown left, PocketPC shown right):

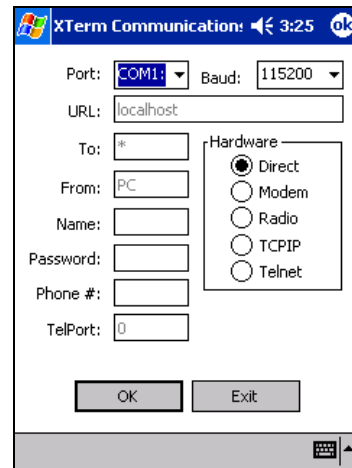
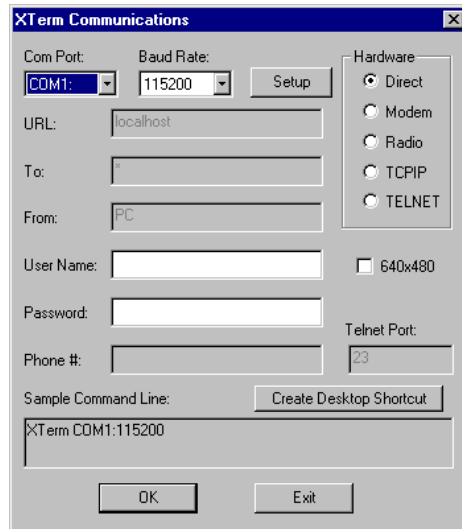

Use the controls on the screen to select the com port, baud rate, type of connection (direct, modem, radio, TCP/IP, Telnet), 640X480 (“big screen” mode when selected) and related values. Setup is an advanced option that allows the SSP timings to be modified to accommodate different types of connections. Select OK and XTerm will begin operation with the type of communications you have selected.

Connection types are as follows:

Direct: Serial cable from Xpert to PC

Modem: Allows Xterm to dial out on a pc modem to a Xpert with modem

Radio: Allows Xterm to control a line of site radio to talk to a Xpert

TCP/IP: Allows Xterm to talk with another Xterm on a PC at the IP address specified (Useful to assist other users, since all actions performed on remote pc are viewed at the pc connected to the Xpert)

Telnet: Allows Xterm to connect to a Xpert unit that is connected to an IP-Serial converter. At the time of writing this, the functionality is limited, and no IP-serial devices have been identified to provide full functionality.

XTerm for the PocketPC does not show the 640x480 “big screen” option since its screen is too small. The sample command line text area is also missing since the PocketPC does not have a command line.

To configure XTerm to remember selections when run from a desktop PC, press the **Create Desktop Shortcut** button. A shortcut that specifies the options you have selected will be placed on the Windows desktop.

Many shortcuts to XTerm may be created, each with a different com port or configuration. Once the shortcut has this additional information, XTerm will not display the communications configuration screen when it starts

## SSP Settings

The Setup button will display the SSP Settings screen containing advanced options for controlling the timing of SSP messages. XTerm is optimized for a 115.2K baud direct connection, and other settings are often necessary for slower or less-reliable connections.

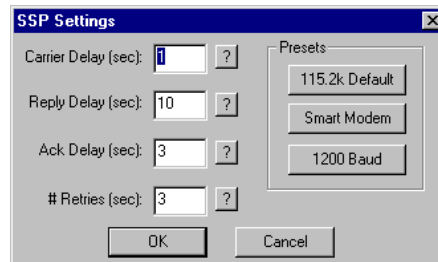

Below is a description of each option and is the same description provided when the corresponding help button (“?”) is pressed:

**Carrier Delay (seconds):** When the com port is set for "RADIO" communications, this is how long to key the transmitter (assert DTR) to warm up the radio before sending data. With Sutron radios typically 1 second or less is needed, but this may need to be increased if hardware repeaters are used in the network, as each hard-repeater in the network needs time to warm-up. Default 1 sec.

**Reply Delay (seconds) :** This is how long the XTerm will wait for a reply before timing out. This delay includes the time needed for all retries to occur, so it's typically set to the value of AckDelay \* (# Retries). Default 10 seconds.

**Ack Delay (seconds):** This is how long to wait for a response to a message (aka an acknowledgement) before attempting a retry. The default value is 3 seconds, which is suitable for a 115.2K baud direct connection. 10 seconds is recommended for a single hop 1200 baud system connection. It should be increased if lower-baud rates or store and forward repeater hops are necessary.

**# Retries:** More precisely, this is the total number of tries. When an SSP request is made that requires a reply the system will wait for the Ack Delay for the reply. If a reply is not received then one or more retries is performed. # Retries is the total number of attempts to make. The default value is 3. Combined with the default Ack Delay of 3 seconds, this means SSP will send the same message as many as 3 times, with a 3 second delay between each attempt before it will timeout and report a "tx error". All retry messages have the same FLAG SEQUENCE number as the original message. This is used to prevent the same message from being processed twice due to a long network delay.

The preset buttons set the SSP timing according to 3 common scenarios. The 115.2k puts the values back to their defaults. Smart Modem selects a very long (1 minute) ack delay and reply delay since it's expected the smart modem will perform retries, and will normally never fail, but may take a while to send data when line conditions are poor. 1200 baud selects settings designed to work with lower-baud rates and dumb radio systems.

## Preparing the Xpert to work with XTerm

The Xpert comes configured at the factory to communicate with XTerm on its COM1 serial port at 115,200 baud. Connect a standard M-F DB9 cable between the PC and the Xpert. A M-M gender changer and a Null Modem are necessary to connect Xpert to the PocketPC.

The program in the Xpert responsible for communicating with XTerm is *remote.exe*. When the Xpert starts up, it will first check for an *autoexec.bat* file in the *flash disk* folder. If the file is not there (factory default condition) the system will automatically run *remote.exe* on com1. However, if the file is there, the system will execute the contents of *autoexec.bat*. In this case, *remote.exe* is run only if there is a line in the file to run it.

In the event that a system has an *autoexec.bat* file that does not run *remote.exe* and you want to run it, reset the Xpert and hold a stylus on the touch screen while it starts. When your touch is detected the system will prompt you to see if you desire to bypass the *autoexec.bat*. Select YES and the Xpert will bypass *autoexec.bat* and run *remote.exe* on com1.

## Operating XTerm

When XTerm runs and communicates with an Xpert that has user accounts setup, you are required to enter a username and password to gain access. When this happens, simply enter a valid username and password.

When XTerm starts you will see a dialog similar to the one below. The left portion of the desktop window shows the contents of the Xpert display. The entire screen of the PocketPC display shows the Xpert display.

When you click (or tap in the case of the PocketPC) in the Xpert portion of the display, the Xpert will respond as if you had used the touch screen on the Xpert itself. The only exception to this is on the PocketPC: when you tap-and-hold the stylus against the screen for a few seconds, XTerm's main menu is displayed. The options on this menu are the same as those provided by the buttons on the right-hand side of the desktop version.

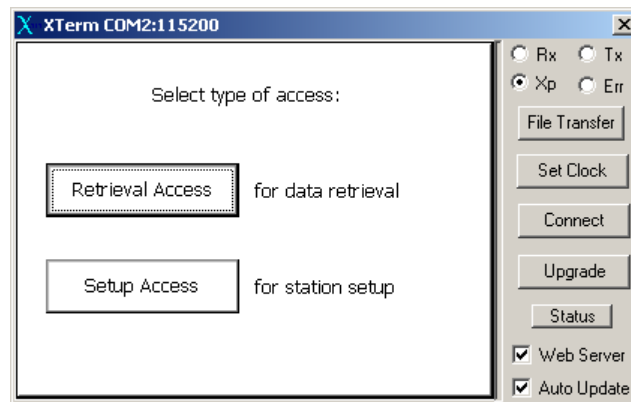

If the screen is blank, or becomes unreadable or garbled, right click in the Xpert display area. This sends a command to the Xpert retrieve again the contents of the display. To do this on the PocketPC, tap and hold the stylus on the screen to access the main menu, and then select "Update Now".

Note that while you operate Xpert from XTerm, the Xpert's physical display (if it has one) will also be changing. If someone is looking at the screen while you are operating the Xpert, they will see all that you are doing. Both the touch screen and PC are active at the same time with the same priority so don't try to work on the Xpert at the same time.

XTerm is very smart when it comes to knowing when and how to update its display. However, the nature of serial communications sometimes causes screen updates to lag slightly, or become garbled. As an example, log-in to the Xpert and select the different tabs of the Xpert display. Notice that it takes time for the Xpert to switch from one tab to another. If you are connected at a baud rate slower than 115,200, the wait for the display to update can be long. If you select a control and don't see an immediate response, wait a bit and try again. Do not click controls rapidly as this will very likely translate into undesired behavior.

When using the desktop version of XTerm, you can use the desktop's keyboard as if it were connected to the Xpert. For example, instead of using the Xpert's virtual keypad (shown below), use your keyboard. The characters typed are sent to the Xpert's keyboard buffer.

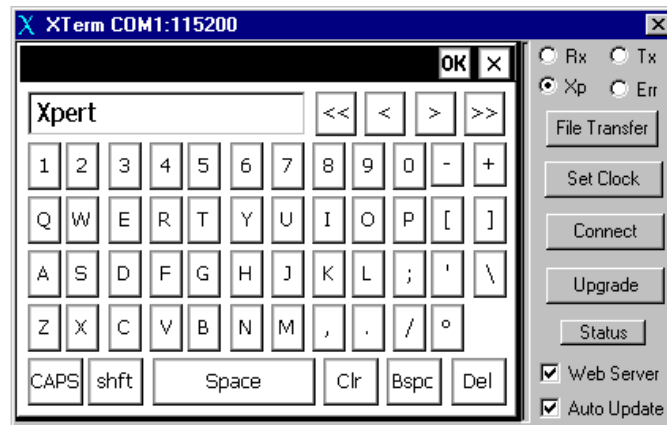

When exporting logs from Xpert using XTerm, XTerm assumes you want to save the exported log on your local PC and so offers a Save-As dialog on the local PC (see below: desktop PC shown left, PocketPC shown right). If you cancel this dialog, then Xpert prompts for the destination on the Xpert disk the file should be saved.

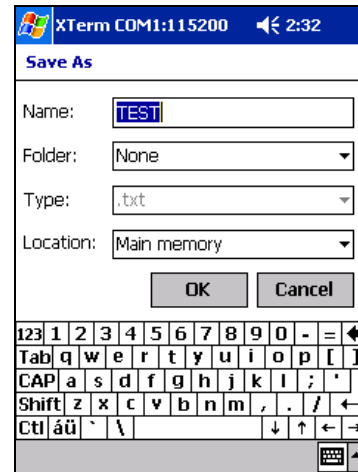
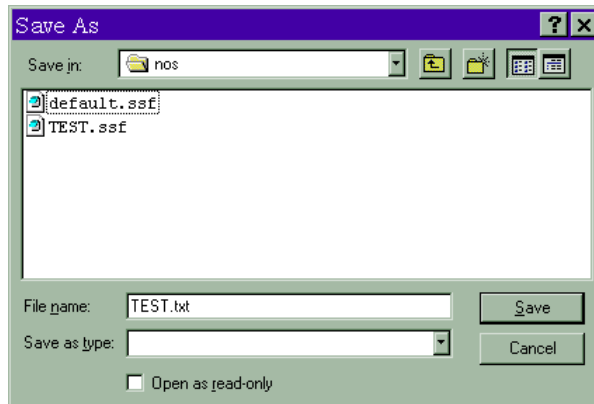

## File Transfer

File Transfer is one of the more powerful features of XTerm. Using File Transfer, you can transfer setups and software between the Xpert and your PC. You can also access special virtual files in the Xpert that describe details about the software that is running.

When you select File Transfer, you will see a window similar to the following (desktop PC shown left, PocketPC shown right):

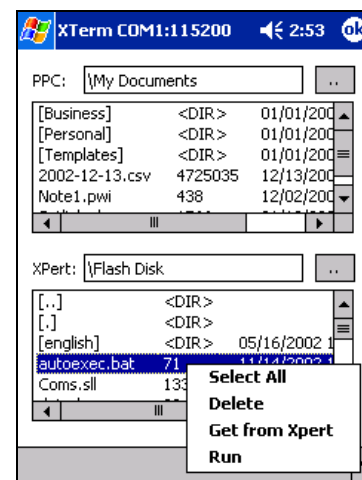
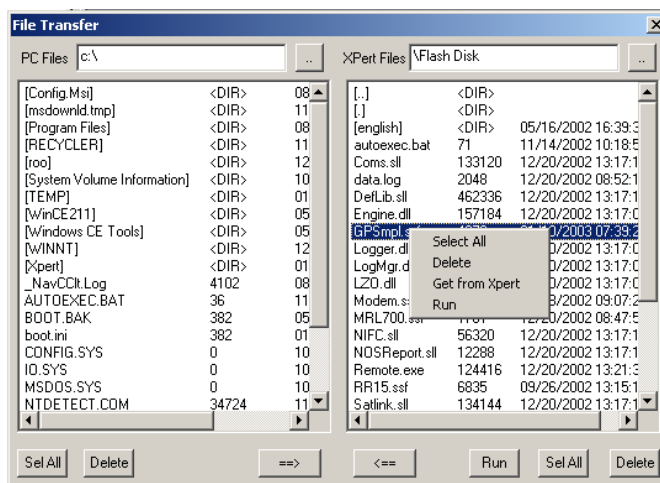

The list on the left (top for PocketPC) shows the files on your PC. The list on the right (bottom for PocketPC) shows the files on the Xpert. You may change the folder that is displayed by simply double clicking on a folder in the window. Selecting the .. control at the top of the window next to the folder name or [..] in the list of files will go to the parent folder.

All the operations you can perform on the file lists can be selected from the file transfer popup menu (shown in the images above). This menu is accessed on the desktop PC by right-clicking in the list. This menu is accessed on the PocketPC by tapping-and-holding the stylus

on the list for a second or two. The desktop PC version also provides buttons to access these operations.

To move a file from the PC to the Xpert, select the file in the PC window and either press the ==> button, or select “Send to Xpert” from the menu. To move a file from the Xpert to the PC, select the file in the Xpert window and either press the <== button, or select “Get from Xpert” from the menu.

On the desktop PC, you can select multiple files by pressing CTRL and then selecting the file with the mouse, or by pressing SHIFT and then selecting the file with the mouse to select a range of files. On the PocketPC, you can select multiple files by pressing and holding the “Action” button while you tap additional files. The “Action” button is typically the largest button on the device below the screen. See your PocketPC documentation for further information.

Use either the *Sel All* button or the “Select All” menu item to select all items in the list.

Use either the *Delete* button or the Delete menu item to delete files on either the PC or Xpert.

Use either the *Run* button or the “Run” menu item to run a program on the Xpert. Note that it is not possible to run a program with command line arguments in this way.

Note that all times displayed on the right side of the file transfer dialog (top, on the Pocket PC), are shown in device-time, which knows nothing about “local” time. All times displayed on the left side (bottom, on the Pocket PC), are shown in PC-time, which reflects a correction for the PC’s local time-zone. This can lead to some confusing behavior when the PC’s local time zone is set to something other than Greenwich Mean Time (GMT), as certainly many are. For example, if you transfer a file from the Xpert to the PC, the file timestamp shown on the PC will be different than what is shown on the Xpert. The key to working through this confusion is to remember the times shown in both cases are each relative to the device on which the file sits (the Xpert or PC).

## **Process List Folder**

The virtual files under the Process List virtual directory give important details on what programs are running in the Xpert. The files are “virtual” in that they do not exist physically as files on the Xpert. The information is organized in this fashion to make it easier to view and transfer for analysis. A sample Process list is shown below. Note that it can take 10 seconds or more for the system to produce the Process List.

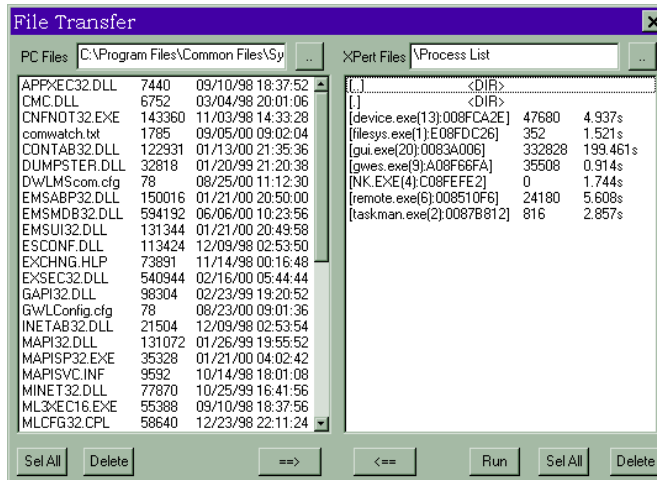

The format of the process information is [name(threads):address] size time, where name is the file name of the process running, threads is the count of threads running, address is the where in memory the program is running, size is the number of bytes used by the program and time is the amount of CPU time in seconds that the program has used.

If you double click on any of the processes, the system will allow you to select threads or heap. A sample thread display is shown below:

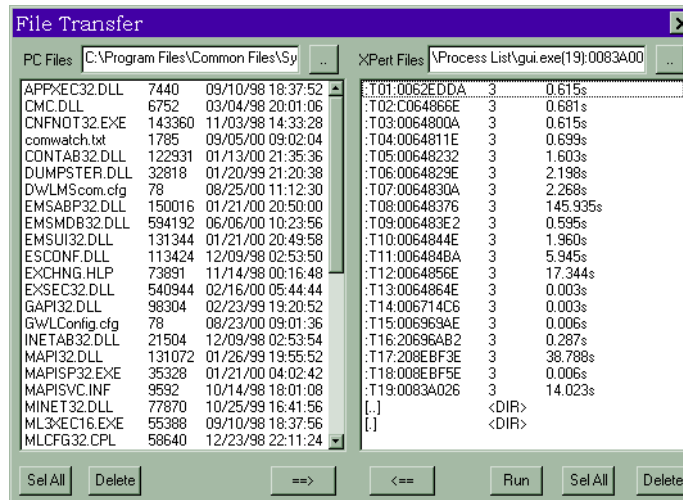

## Set Clock

When you press the *Set Clock* button, XTerm prompts, “Would you like to set the Xpert’s time to match your PC”. If you press YES, the Xpert’s clock will be set to match the PC clock. Press NO if you do not wish the time to be set.

## Connect

Pressing the *Connect* button brings up the configuration dialog shown and described in the section on installing XTerm. This allows you to change your connection once XTerm has been started.

## Upgrade

Pressing the *Upgrade* button brings up a dialog asking for the location of the upgrade file to use to perform a scripted upgrade of the firmware in the 9210. Please see **Appendix B** for more information on how to upgrade.

## Web Server

The Web Server check box selects whether or not XTerm should act as a web server proxy for the Xpert. When this box is checked, any web pages on the Xpert will be made available as-if they were actually hosted on your PC. For instance, in Internet Explorer you could enter the URL `http://localhost` to access the Xpert's homepage. If your PC is on a LAN, WAN, or the Internet, then the Xpert's home page can be reached by other users by entering `http://yourIPorURL`.

Regardless of the setting of this box, XTerm always acts as a proxy for other XTerm users on the network. For instance you can test this out by starting a second copy of XTerm with the following command: "XTerm remote://localhost", or from another machine on the network via "XTerm remote://yourIPorURL". If you have a firewall, you may need to add an access rule for the following services:

```
GUI_PORT    52732 TCP
REMOTE_PORT 52733 TCP
SSP_PORT    52734 TCP
```

## Auto Update

The auto update checkbox causes XTerm to continuously request screen updates. When the checkbox is clear XTerm will conserve the Xpert's power and CPU by only requesting updates for a short time after a key press or a touch.

## Configuring the PC modem for use with Xterm

Most PC modems will work with Xterm without any additional configuration needed, simply select the com port the modem is using from the com port drop down box, select the hardware type as modem, and set the baud rate (if needed), and enter the phone number.

If Xterm gives this dialog:



Then check to make sure no other program is using the modem and that the correct com port is selected.

If Xterm gives this dialog:



First check that the phone number has been entered correctly (enter 1 and area code if needed). Then, use Hyperterminal (or other terminal program) and connect to the com port the modem is on. Issue an AT&F command and see OK, if you do not see an OK, then the modem is not working, or is not on that com port. If you get the OK, then issue an AT&FV1&W command to the modem, then close the terminal program and try Xterm again.

## Status and Rx, Tx, Xp, Err indicators

XTerm features four status indicators:

Rx: Flashes when a message is received.

Tx: Flashes when a message is sent.

Xp: Is lit when XTerm has detected that the Xpert application is running and that communications necessary for a log dump has occurred.

Err: Flashes when a message is received that has errors. If you see this often, then your serial cable may be suffering from crosstalk (be wary of very thin serial cables designed to be used for mice), or your PC may not be capable of keeping up with 115.2K baud serial communication. You could try a slower baud rate (57.6K baud) or a different com port. USB serial ports may have more problems with higher speeds than legacy ports.

The Status button brings up the Communication Status window:

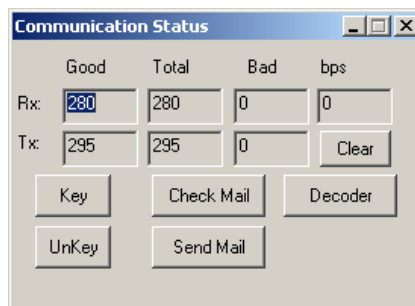

The Status screen displays information about the current session and allows some testing of the SSP (Sutron Standard Protocol) connection:

Rx Good: Number of SSP messages received addressed to your PC;

Rx Total: Total messages received. SSP supports multi-drop (most common with LOS radio systems) where messages can be sent to any station in a network;

Rx Bad: Number of bad SSP messages detected. This would be messages which could not pass a CRC-16 check.

Tx Good: Number of SSP messages transmitted, and acknowledged.

Tx Total: Number SSP messages attempted.

Tx Bad: Number of times an SSP message could not be sent.

Clear: Sets all the statistics to zero.

Bps: The number of bits received and or transmitted per second (computed using a 2-second moving average). If screen updates or file transfers seem sluggish it might be because you're not achieving a very high (bps). This can be caused for numerous reasons including an underpowered PC, communication errors, or just that the Xpert is very busy with processing. The rate achieved will vary depending on what's being performed. For instance, under even the best circumstances, a file transfer to the Xpert will be limited by how fast the Flash Disk can be written.

Key: This keys (powers on) a radio transmitter (asserts DTR and RTS) and can only be used when XTerm is configured to communicate with a LOS Radio.

UnKey: This unkeys a radio transmitter (drops DTR and RTS) and can only be used when XTerm is configured to communicate with a LOS Radio.

Check Mail: This checks to see if you've received a mail message via SSP. When a mail message is received you may hear a beep or the RingOut.Wav file played if it's on your system. If you wish to test this, you can go to the Setup menu on the Xpert, select Coms, press Edit, press Test, and click Send Mail.

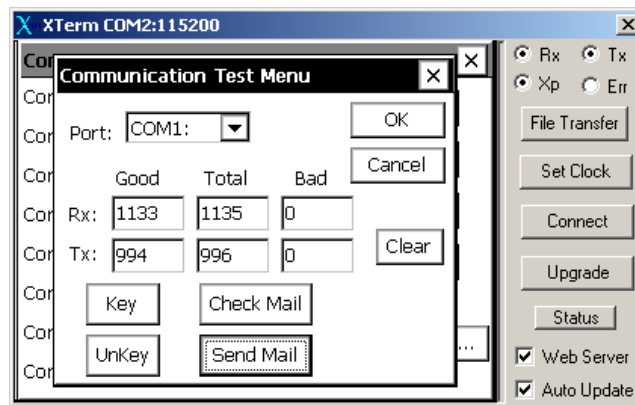

Send Mail: This will prompt for a mail message to send to an Xpert. If successful "Mail Delivered" will be displayed.

Decoder: This is an SSP message decoder that can be helpful for trouble shooting SSP communication problems. The information displayed requires an understanding of the SSP protocol, which is beyond the scope of this manual. However, if you experience some sort of

repeatable communication failure, a screen capture of the Decoder window can very helpful to Sutron support staff in figuring out what's going wrong.

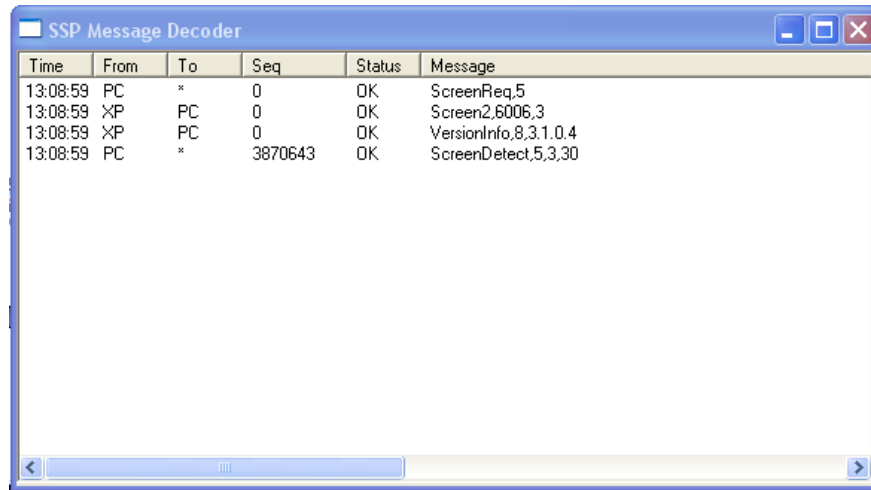

The screenshot shows a window titled "SSP Message Decoder" with a table of messages. The table has columns for Time, From, To, Seq, Status, and Message. The messages are as follows:

Time	From	To	Seq	Status	Message
13:08:59	PC	*	0	OK	ScreenReq,5
13:08:59	XP	PC	0	OK	Screen2,6006,3
13:08:59	XP	PC	0	OK	VersionInfo,8,3,1,0.4
13:08:59	PC	*	3870643	OK	ScreenDetect,5,3,30

## Special Command Line Options

XTerm supports some special options which are not configurable through the CONNECT screen and must be passed on the command line.

/NOHS - disables H/W Handshaking (flow control) allowing Xterm to be used over a 3-line serial port.

/STATS - causes the "Communication Status" screen to be displayed on startup.

/DECODER - causes the "SSP Message Decoder" screen to be displayed on startup.







# **Chapter 7: Installation**

## STEPS TO INSTALL AN XPERT

---

1. Connect Earth Ground to the Earth connection. The earth connection is on the side of the Xpert (next to the PCMCIA slot). **WARNING:** Failure to ground the Xpert can make it susceptible to malfunction or damage by surges and other types of interference.
2. Optional: Wire sensors to the SDI-12 port on the Xpert. You can insert multiple wires into each connection. If the connection is awkward to use, run wires to a separate terminal strip. Note: on the Xpert, you may need to temporarily remove the I2C connector to get better access to the SDI-12 port.
3. Optional: Connect I/O modules together, if multiple modules of the same type are used (i.e. 3 Analog I/O modules) note the serial number of each module before connecting them, you will need this for configuration. Mount as desired. Wire sensors to the terminal strips as needed. Connect I/O modules to the Xpert I2C connection.
4. Optional: Connect SATLINK, SPEECH/MODEM or other communication devices to the desired communications port COM2, COM3 or COM4. The Xpert is wired as DTE so use a straight cable to make the connection. (Note: if your Xpert has COM2, 3 and 4 as Female connections, the ports are still DTE). If you are connecting a modem or other devices to the Xpert, you will need to modify the autoexec.bat to support these devices as explained in the sections that follow.
5. Connect a PC to COM1 using a straight through cable.
6. Connect power to the Xpert. Turn on the power. Observe the Xpert startup.
7. Press Setup Access and log into the Xpert.
8. If you are using I/O modules do the following to make sure the I/O modules are at the desired addresses.
  - a. Select the Setup tab
  - b. Select the + in front of the I/O Module label
  - c. Examine the names of the I/O modules. The names will be AIO and DIO followed by a module number. For each type of module (AIO or DIO) there can be only one number of each type (e.g. there can't be two AIO1 modules). If there are, follow the next step to change. Furthermore, the setup will expect you to connect sensors based on the module number. You have multiple AIO or DIO modules, make sure they each have the proper module number.
  - d. Select each module and press EDIT. Examine the name, serial number and module number.
  - e. If you want to change a module number use the button to enter a new module number.
9. If you have a users.dat file use XTerm to load it into the flash disk. This defines the login accounts for the Xpert. If you don't have a user.dat file you may use the users branch of the Setup tab to set one up. Then save it back to the PC so you can use it at other sites if desired.
10. If you will be using a voice modem, transfer to the Xpert the desired speech files. The speech files take up considerable space on the flash disk. Therefore, you will only want to send to the Xpert the files you expect to need. The speech files are found on the diskette provided by Sutron with the Xpert. The speech files can also be downloaded from the Sutron web site. On the diskette, files in the main \ENGLISH

folder are essential for basic speech operation. Files in the \ENGLISH\ENGLISH-EXTRA should only be loaded as needed. Use XTerm to transfer the files to the appropriate folder in the \flash disk\speech\ (\English, \Spanish etc.). If the folders do not exist in the Xpert, use HyperTerminal and issue the MD command to create the desired folders. If you want to create your own speech files, refer to the procedure given in Appendix F.

11. If you have a setup file(s) for the Xpert (default.ssf or anyone.ssf) use XTerm to load them into the flash disk. When the Xpert starts, it will first try to load a setup file that matches the station name. If it doesn't exist, the Xpert will try to load a setup file named default.ssf. If you don't have a setup file you will need to create one. See Chapter 4 for details. After creating the file, save it with the name that matches the station name (*station\_name.ssf* or default.ssf if you want it to be used at startup. Copy it to the PC so it can be used at other stations. You may also need to create log files if you are creating your own setup. You typically create log files from the Setup tab. Note: when you load a setup into the Xpert, it will automatically create a log file for you if the setup calls for it.
12. Review the setup to make sure it is the desired setup for the station.
13. If you are using a Satlink select the Setup tab, press the + in front of Satlink and do the following:
  - a. Select Satlink and press Edit. Verify the transmission ID is correct. Verify the com port is correct.
  - b. Select Satlink Self-Timed. Verify settings.
  - c. Select Satlink Random. Verify settings.
  - d. Select Self Timed Test
  - e. Verify the sample formatted message.
  - f. Select Status.
  - g. Verify that the status from Satlink is displayed.
  - h. Verify that the GPS is being received.
14. If using a modem or other device connected to the Xpert, configure the coms section of the Setup tab, then.
  - a. Select coms from Cotrol Panel tab, press EDIT.
  - b. Set appropriate com port to your device type (I.E. Select "MODEM" on com 3). NOTE: SATLINK is configured under Satlink section, so if a Satlink were connected to com2, you would leave com2 as "NONE" in coms section.
  - c. Select the + in front of COMS label.
  - d. Select appropriate com port and press EDIT.
  - e. Configure the device. NOTE: Configure properties will automatically change based on settings from step b (I.E. selecting com3 would show MODEM configuration)
  - f. Once you are done press OK, Xpert will configure each com port.
15. If you have sensors connected to the Xpert you will want to test them to make sure they are operating properly. To test them do the following:
  - a. Turn recording ON. This causes the system to fully activate the I/O modules.
  - b. Select the View Channels tab. You will see a list of all the sensors connected to the system, the channel/module assignments and the last measured value.

- c. Select each sensor and press the measure button. Verify that the new value displayed is correct.
  - d. If you have SDI-12 sensors, you may also want to press the SDI button. Then issue commands to the SDI-12 sensors to configure them or test their operation.
16. Check to make sure Recording is ON. If you had to go into the setup to make changes, there is a chance that the recording is OFF.
  17. Select the Log tab. Select the desired log file and verify that the data is being stored there as desired.
  18. Select the Status tab. Look for any errors that may be reported in the status box.
  19. Finally, go to the MAIN tab and click LOG OUT.

# USING COM PORTS

---

## Overview

The Xpert has four RS232 COM ports (Optionally eight) that can be used for communications devices and serial sensors (with sensor specific setup blocks). The units are configured from the factory to provide +5 volts out on COM3 pin 9, this allows a Sutron Xpert Voice modem to be connected with one serial cable, to communicate and provide power, without the need to open the unit. Pin 9 of all ports except com 1 are user configurable for Ring In (RI), +5 Vdc out or +12 Vdc out (input power)

COM1 is a modified DCE (Female), COM2 through COMx are a DTE (Male). Com 1 has pins 1 and 9 as inputs, normal DCE would use these as outputs.

(Note: Early models have COM2 - 4 as DTE with a female connector).

DCE ports are connected to a PC using a M/F DB-9 straight-thru cable. The DTE ports can be wired to modems and Satlink using straight cables.

## Pin-out information

COM1 – modified DCE Female

DCE	Signal Name	Direction
1	CD	IN (modified)
2	RD	OUT
3	TX	IN
4	DTR	IN
5	GND	
6	DSR	OUT
7	RTS	IN
8	CTS	OUT
9	RI	In (modified)

COM2 - 4 (6-9 if installed) – DTE Male

DTE	Signal Name	Direction
1	CD	IN
2	RD	IN
3	TX	OUT

4	DTR	OUT
5	GND	
6	DSR	IN
7	RTS	OUT
8	CTS	IN
9	Set by jumpers to RI, +5V or +12V	

## Jumper Settings

The following table gives the jumper settings and their default settings. Com ports 2-4 have two jumpers on each com port board. The optional Quad Serial board has jumpers on it (near the ribbon cable connections) for all four ports. A jumper diagram is included on the board to assist in configuring the ports. If the factory defaults do not meet your application, you will need to open the Xpert to change these jumpers.

COM2-4

	Function	COM2 and 4 Default (COM 6-9 if installed)	COM3 Default
J1, 2-3 J2, 2-3	+5V		<b>X</b>
J1, 2-3 J2, 1-2	+12V		
J1, 1 to 2 J2, doesn't matter	Ring IN	<b>X</b>	

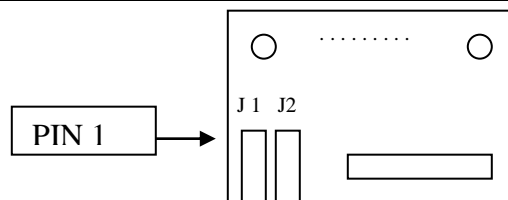

COM6-9 Quad Serial board (Optional)

Each COM port has a set of jumpers associated with it. Viewing the boards with the ribbon cable header to the top, the associated jumpers for each port is directly below the header. The

diagram on the board shows where to place the jumpers to get the different configurations for pin 9.

<b>TO GET</b>	<b>RI</b>	<b>+5 (Switched )</b>	<b>+5 (Always on)</b>	<b>+12 (Switched )</b>	<b>+12 (Always On)</b>
<b>Place jumpers across these pins</b>	1-2 5-6 9-10	2-4 3-5 9-10	2-4 3-5 7-8	2-4 5-6 9-10	2-4 5-6 7-8

Jumper PIN-OUT

2	4	6	8	10
1	3	5	7	9

## Maximum Current Draw from Pin 9

### Xpert Com 2 - 4

**+12 Vdc** selected = **500mA** maximum total **on all ports including** SDI-12 +12 Vdc.

Example 1: The unit has no SDI-12 sensors connected and one com port is configured for +12 Vdc. The port can supply 500mA out.

Example 2: The unit has a SDI-12 sensor (sensor draws 20mA max) connected and two com ports configured for +12Vdc out. The two com ports can supply a total of 480mA, split in any combination, such as 240/240mA, 100/380mA, etc.

**+5 Vdc** selected = **200mA** maximum available on **each** port

### Xpert com 5 - 9 (Optional Quad Serial board)

**+5 Vdc** or **+12 Vdc** selected = **300mA** maximum available on **each** port

## OPTIONAL RS-485 COM PORT

### Overview

Any of the three RS-232 com port boards may be replaced with the RS-485 com port board (6461-1251-1). This board will allow RS-485 communications to sensors or other data loggers, when configured in the software.

Currently, the only RS-485 sensors are the MRL radar sensor and a SDI-12 protocol over RS-485 interface (with optional sll, RS485SDI.sll). Both of these will currently only talk out on COM 4 and do not switch the power for pin 8 (it is always on).

## Pinouts

The pin outs of the DB-9 are as follows:

PI N	SIGNAL
2	RS-485 B
3	RS-485 A
5	Ground
8	Switched Voltage *
9	Constant Voltage (from Xpert input power)

\* Set to +5 or +12 (input power) via J3

## Switched power settings

The switched power can be set to +5 volts or +12 volts (input power). For +5 volts, set the jumper across pins 1-2. For +12 volts (input power), set the jumper across pins 2-3.

This switched power is turned on when the receivers are enabled, and turned off when the receivers are disabled. If it is desired to provide a switched power, then the software must turn on the receivers when communications need to take place, and leave them enabled until the response is received.

## Maximum current draw from constant and switched power pins

PIN 8 (+12 volts selected) or Pin 9 constant power

**500mA** maximum total **on all ports including** SDI-12 +12 Vdc.

Example 1: The unit has no SDI-12 sensors connected and one com port is configured for +12 Vdc. The port can supply 500mA out.

Example 2: The unit has a SDI-12 sensor (sensor draws 20mA max) connected and two com ports configured for +12Vdc out. The two com ports can supply a total of 480mA, split in any combination, such as 240/240mA, 100/380mA, etc.

Pin 8 (+5 volts selected)

**200mA** maximum

# **Chapter 8: Maintenance and Troubleshooting**

## **COMMON MAINTENANCE AND TROUBLESHOOTING**

---

### **Calibrate the Touchscreen**

There are two ways to start the touch screen calibration program

Using XTerm , select the program \windows\touchcal.exe. Before pressing RUN, hold a stylus on the touch screen in the upper left corner. Then press RUN. As soon as the you hear the tones from the Xpert, remove the stylus. The touch screen calibration screen will appear.

Power off the Xpert. Then turn on the power holding a stylus in the upper left corner. As soon as you hear tones from the Xpert remove the stylus. The touch screen calibration screen will appear.

Once the calibration program is running, use the stylus and carefully place it in the center of the + that appears. Hold it for 2 seconds in each spot and then release it. The + will move to another part of the screen. Continue until the prompt: "tap the screen to save settings" appears. If you don't want to save the settings, wait for the screen to timeout and then start the calibration program again.

### **Skip the autoexec.bat**

If a unit does not appear to be running the Xpert app (blank screen) or communicating with a PC, then it is possible that the autoexec.bat file has become corrupted, or modified incorrectly. Follow these steps to skip the autoexec.bat file:

For an Xpert with a LCD display, hold the stylus in the center of the touch screen, and then apply power. Leave the stylus on the touch screen until you see a prompt to skip autoexec.bat, and then press YES.

For a non-display Xpert, connect a PC running a terminal program to COM1 and apply power to the unit. After the terminal displays "Flushing caches", press CTRL key and C <CTRL-C>, hold until message displays "Bypassing \flash disk\Autoexec.bat..."

Once the unit has finished booting, the autoexec.bat file may be retrieved from the unit, modified, and then transferred back onto the unit. Re-apply power and let the unit execute the new autoexec.bat file to verify it is fixed.

### **Xterm has a White screen or Black Screen**

When using Xterm to talk with a Xpert, if the screen area does not show the login prompt or menus:

**Black screen-** This indicates the unit is not communicating. Check that the unit has power and that the serial cable is connected. Also check that the correct com port and baud rates have been selected.

**White screen-** This indicates that Xterm is communicating with the Xpert, but no program is running. First try right-clicking into the screen area to ensure the screen is updated. Check that the unit has an autoexec.bat by using file transfer, if it doesn't, send one to the unit (either create one following APPENDIX F or get it from the web site) and reboot it. If it does have one, transfer it to the pc and edit it to make sure it has the line \windows\xpert.exe in it.

If the unit has the autoexec.bat and it has the line to run the xpert.exe in it, then close xterm, run a terminal program (@ 115200,8,N,1) and reboot the xpert. You should see the very last line of bootup information showing:

Running \windows\xpert.exe.

Launch complete.

If you do not see this, or get any other errors, contact customer service for further assistance.

## Adjust the contrast

On power up, the Xpert starts with the contrast at a fixed value. You may change the contrast either at the login screen or at the main tab of the Xpert. When the login screen is displayed, tapping the touch screen in the upper right corner will darken the contrast while tapping the touch screen in the lower right corner will lighten the contrast. Wait at least 2 seconds between each tap to give the display a chance to adjust to the new contrast setting.

At the main tab of the Xpert you will find a display of the contrast voltage and two buttons to press to adjust the contrast. Pressing <= will lighten the contrast and pressing => will darken it. The corresponding voltage will also be displayed.

## Replace the Internal Battery every 5 years

**DISCONNECT POWER** before opening the unit, as dangerous high voltages exist inside the unit to power the backlight

The Xpert has an internal lithium battery to keep the clock running when power is removed. This battery should be replaced every 5 years if the Xpert has been operating. The battery may need to be replaced sooner if the Xpert is not powered up for extended periods. Typically, on a unit that is sitting on the shelf with no power applied, the battery will last for 2 years. The battery is a 3 Volt, CR2032 type coin cell.

Upon power-up, the battery voltage is checked, if it falls below 2.4 volts, a message will appear warning that the internal battery is low. Note: You will need to set the time and contrast after replacing the battery, then remove and re-apply power to remove the warning about a low battery.

To replace the battery, remove the 8 screws holding the bottom of the case to the top, slide the bottom out of the top, locate the battery on the power supply card, use a small screwdriver to help lift the battery out of the holder, slide the new battery into the holder.

## Cleaning Instructions

The touch screen can be cleaned with common mild window cleaning products. To clean the Xpert touch screen, spray the cleaner on a clean cloth and then wipe the touch screen. Do not spray directly on the touch screen as the cleaner may run down into the Xpert. You do not need to remove the power from the Xpert to clean the touch screen.

The Xpert case can be cleaned using common mild window cleaning products. Do not spray the cleaner directly on the Xpert. Instead, spray the cleaner on to a clean cloth and then wipe the case clean. Never spray cleaner directly on the terminal strips or on the wiring.

## **Fuses**

There are no replaceable fuses in the Xpert. The Xpert does use a number of self-resetting fuses to help protect the unit from damage when lines coming from the Xpert are shorted. You may optionally use a fuse in the cable you connect to provide the Xpert with power. This fuse should be rated for at least 2 amps.

# **Appendix A: Setup Blocks**

## INTRODUCTION

---

The power of the Xpert is in its setup blocks. These blocks do the work of measuring, processing, logging and telemetry. Sutron will regularly develop new setup blocks to provide an expanding support for new sensors and updated processing. Customers will also be able to create setup blocks using optional software available from Sutron.

Following is a list of setup blocks that are provided with the system. The blocks are grouped as sensor blocks, processing blocks, log blocks, telemetry blocks, control blocks, and miscellaneous blocks.

# SENSOR BLOCKS

---



## Air Temperature Sensor (AirTemp)

### Inputs

<none>

### Outputs

AirTemp

### Wiring

Connect the thermistor as shown below. Set the excitation channel and the measurement channel the same.

NOTE: DO NOT USE CHANNELS ABOVE 8 FOR EXCITATION.



### Description

This block supports temperature sensors based on the YSI44006, YSI44032 and YSI44036 thermistors. The AirTemp block makes a resistance measurement of the temperature and then converts the resistance to temperature. Choose the Analog I/O Module number, the analog channel (input) the sensor is hooked to, and the units this block should output the temperature in.

The following table shows the thermistor used by the different Sutron sensors:

Sutron Sensor	Thermistor
5600-0010	Linear*
5600-0011	44032
5600-0020	Linear*
5600-0025	44036
5600-0030	44036

\* When this air temp block is used with linear sensors, a double voltage measurement is made. If desired, a linear sensor can also be measured by the voltage block and appropriate values for slope and offset

**Air Temp Thermistor Properties** [X]

Analog I/O Module: 1 [v] [OK]

Channel: 1 [v] [Cancel]

Thermistor ID: YSI 44036 [v]

Units

F  C



## Air Temperature/Relative Humidity (AT/RH)

### Inputs

<none>

### Outputs

TempOut

HumidOut

### Wiring

Wire each output to a separate analog channel

Power the sensor off of the Battery of SW12 as selected in the setup.

### Description

This block supports the Sutron air temperature/relative humidity sensors 5600-0311, -12, -13, -14 and the analog output of the Rotronic HygroClip S3 sensor. Select the proper Analog I/O module, temperature channel, humidity channel, and temperature units. If the sensor is hooked up to a constant power source (that is, either to the battery directly or the Batt terminal of the module) select *Batt* for power. If the sensor is hooked to the SwBatt terminal of the module so as to not draw current unless the sensor is begin sampled, select *SW Batt* for power. Specify the number of seconds the sensor should be powered prior to measurement in Warmup (s). To keep the block from ever outputting greater than 100 for humidity (corresponding to 100% relative humidity) check the box next to *Limit Humidity*.

AT/RH 5600 Properties

AIO Module: 1 Power: Batt

Temp Chan: 1 Type: 5600-0311

Hum Chan: 2 Warmup (s): 3 ...

Limit RH to 100%

Temp Units  
 Celsius  Fahrenheit

OK Cancel



## Analog (ADC)

### Inputs

<none>

### Outputs

AIOData

### Wiring

This section discusses the many different ways to use the ADC block from a wiring perspective.

#### *Excitation*

Many sensors are resistive or ratiometric in nature and need an excitation voltage. A programmable excitation is available that is turned on during the measurement by checking the “Excitation On” box.

Any of the 6 analog channels can also provide the excitation output. Select which channel to use as well as the appropriate excitation voltage. When needed, the Xpert will measure the excitation output voltage.

NOTE: DO NOT USE CHANNELS ABOVE 8 FOR EXCITATION.

#### *Voltage – Single Ended*

Sensor Vout connect to any analog channel CH1..CH6

#### *Voltage – Differential*

Sensor V+, V- connect to any pair of analog Channels CH1/CH2, CH3/CH4 or CH5/CH6. The lower channel of each pair is for the + connection on the Xpert.

#### *Current 4-20 ma*

Connect the sensor to Vbat or +12 SW. Connect the other end of the sensor to the selected analog channel CH1..CH6.

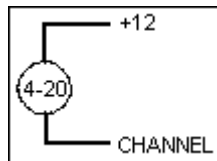

#### *DC Resistance – General Information*

Resistance measurements always require excitation on and a selection for the excitation voltage. The excitation channel may be different from the measurement channel for 3 and 4 wire measurements.

### ***DC Resistance – 2 wire***

Set excitation channel to match input channel.

Connect one end of the resistor to the selected analog channel CH1..CHxx.

Connect the other end of the resistor to GND

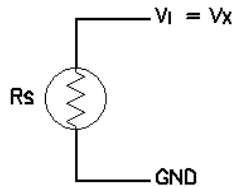

### ***DC Resistance – 3 wire***

Set excitation channel to be different from input channel.

Connect one end of the resistor to excitation channel and input channel using separate wires.

Connect the other end of the resistor to GND

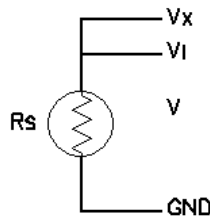

### ***DC Resistance – 4 wire***

Set excitation channel to be different from input channel.

Select differential measurement.

Connect one end of the resistor to excitation channel and input channel (CH1, CH3 or CH5) using separate wires.

Connect the other end of the resistor to an input channel (CH2, CH4, or CH6) and GND using separate wires.

Connect the sensor to channels 1,2; 3,4; etc. as selected for a differential measurement.

Connect the sensor as shown below.

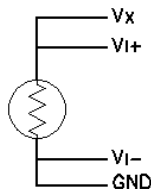

### ***AC Resistance – 2 wire***

Set excitation channel to match input channel.

See connection information for DC Resistance.

### ***AC Resistance – 3 wire***

Set excitation channel to be different from input channel.

See connection information for DC Resistance.

### ***AC Resistance – 4 wire***

Set excitation channel to be different from input channel.

Select differential measurement.

See connection information for DC Resistance.

### ***Thermistor – 2 wire***

Set excitation channel to match input channel.

Connect the thermistor (or any resistance device) as shown below. The excitation channel is  $V_x$ . The input channel is  $V_i$ .

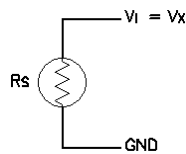

### ***Thermistor – 3 wire***

Connect the thermistor (or any resistance device) as follows. The excitation channel is  $V_x$ . The input channel is  $V_i$ .

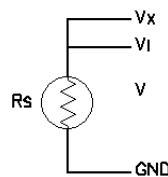

### ***Thermistor – 4 wire***

Set excitation channel to be different from input channel.

Select differential measurement.

Connect one end of the resistor to excitation channel and input channel (CH1, CH3 or CH5) using separate wires.

Connect the other end of the resistor to an input channel (CH2, CH4, or CH6) and GND using separate wires.

Connect the sensor to channels 1,2; 3,4; etc. as selected for a differential measurement.  
Connect the sensor as shown below.

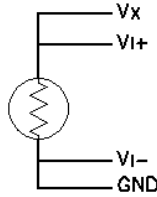

### DoubleVolts

DoubleVolts is intended for making ratiometric measurements for a potentiometer and other similar ratiometric devices. The output value is the ratio of  $V_i/V_x$ . Since both  $V_i$  and  $V_x$  are measured, the measurement is called DoubleVolts.

Set excitation channel to be different from input channel.

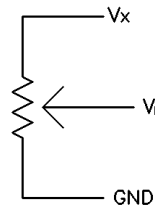

### Description

The Analog block is a general-purpose setup block for making voltage, current, resistance, or thermistor resistance measurements from an Analog I/O Module. One analog output and/or one analog input can be setup with each Analog block. Reading the information on the Analog I/O Module in Appendix C: I/O Modules will help with the understanding of this powerful block.

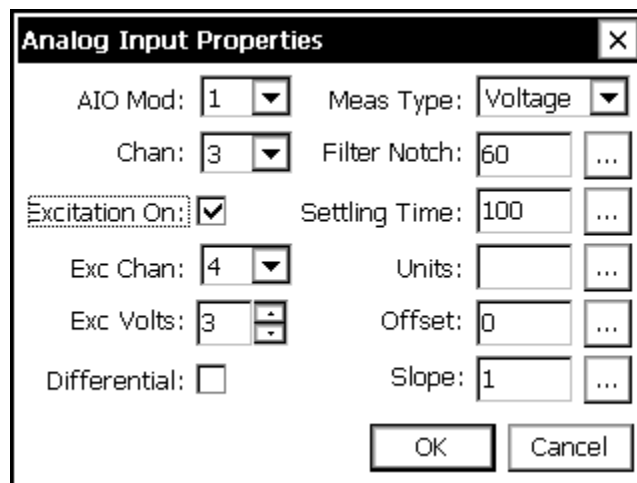

The block scales the outputs according to the values of *Slope* and *Offset* using the equation  $output = reading * slope + offset$ .

The user can change the units for all the outputs by changing the *Units* field to the desired value.

The block supports calibration from the Sensors page. For the calibration, the user will enter the current value sensor. The system will then adjust the offset so the desired value is obtained.

To setup a sensor with the Analog block, first select the Analog I/O module to use. Then select what is to be measured under *Measurement*:

**Voltage:** This is for performing standard analog voltage measurements, similar to what could be done with the VoltMeter block. It requires one input channel for a single-ended measurement or an input channel pair for a differential measurement.

**Current (4-20mA):** This is for making current measurements in the range of 0 to 20ma. It requires one input channel for a single-ended measurement or an input channel pair for a differential measurement. The dialog changes slightly when this measurement type is selected:

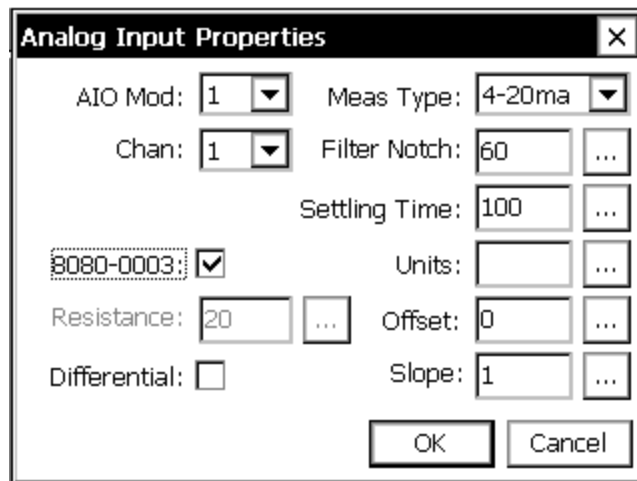

When measuring using an Xpert AIO module, make sure “8080-0003” is checked (this option is typically only used on the Xlite/9210).

**DC resistance:** To measure resistance, set-up an excitation channel and hook the device or medium to be measured between this channel and ground. The I/O module will do a voltage over current calculation to determine the resistance. The excitation voltage should be set to a value appropriate to the approximate resistance being measured. DC resistance uses a built-in precision 20 ohm resistor as the reference for the resistance measurement.

**AC resistance:** If this is selected, the I/O module will take two measurements for every measurement value the block outputs. The first measurement is done using the voltage specified by the excitation voltage and the second with this voltage negated. This can be used in cases where applying a DC excitation voltage would cause undesirable changes to the medium being measured.

**Thermistor:** This is a specialized resistance measurement geared for thermistors. A 10k internal resistor is used instead of the standard and the excitation channel voltage is overridden to be 5V.

**Volts HiGain:** When you select the “Volts HiGain” measurement type, a voltage measurement is made using hi gain. The maximum input voltage is 312mV when measuring using the 8080-0003 Analog IO module, and is 78mV when measuring using the 8080-0007 Analog IO module.

**Volts x128:** When you select the “Volts x128” measurement type, a voltage measurement is made using very high gain. The maximum input voltage is 39mV when measuring using the 8080-0003 Analog IO module, and is 19mV when measuring using the 8080-0007 Analog IO module.

Differential measurements can be made for each of the above *Measurement* choices. If you specify a differential measurement, be sure to select only channels 1, 3 or 5

To enable an excitation channel click *Excitation On* and then select the channel number to use and the voltage level to output. Xpert can generate excitation voltages on any channel (1-6). NOTE: DO NOT USE CHANNELS ABOVE 8 FOR EXCITATION

**Filter notch:** This is a built in noise filter, the defaults of 60 should work for many measurements. If AC line noise becomes an issue, lowering this value will help reduce the noise. Lowering this value will also make measurements take longer.

**Settling Time:** This is the amount of time in milliseconds to leave the A/D(circuitry and VREF to sensors) powered before taking measurements. Sensors requiring a longer settling time, also called warm-up time, should have this value increased.

## **BP** Barometric Pressure (BP)

### Inputs

<none>

### Outputs

BP

Temp

### Wiring

Connect the sensor to the SDI-12 port.

### Description

This block supports the Sutron Accubar Barometer, part #5600-0120. This is an SDI-12 sensor. Select the pressure units, the SDI-12 address of the sensor and the averaging time (averaging time is used to increase the measurement accuracy by lengthening the sampling time). This block can also return temperature by clicking the box next to *Enable Temperature* and selecting the desired temperature units.

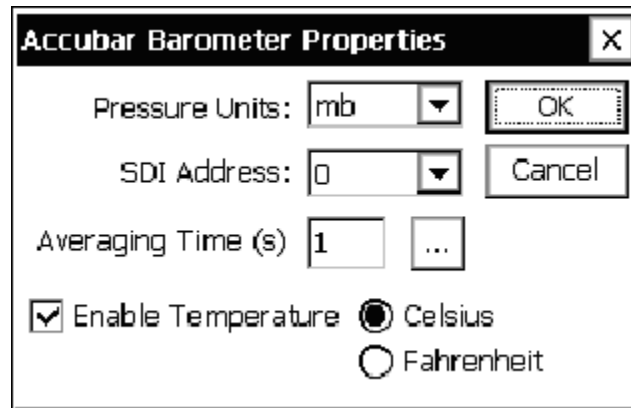

## BEI Absolute Encoder (BEIEnc)

### Inputs

<none>

### Outputs

Output

### Wiring

Connect the sensor to a RS232 port as follows (wiring is shown for the 6461-1239 protection board):

Color	Name	Pin (6461-1239)
Red	+12	6
White	RXD	2
Blue	TXD	3
Green	DTR	1
BLK/Brown	GND	5

Note: (jumper J3 on the 6461-1239 to DTR)

Also make sure to configure Xpert for +12 on pin 9 of the DB9.

Also note that the encoder must be set to 4800, N, 8, 1.

### Description

This block supports the BEI Absolute shaft encoder. This encoder connects to any of the Xpert RS232 ports. See the section *Wiring* for the details of the connections. There are three user set properties for the BEI Encoder: Com Port, Range and Offset. Use Com Port to specify which RS232 port the encoder is connected to. **NOTE:** Leave the settings in the SETUP TAB/ COMS set to none, as this block will not be able to use the com port if coms is already using it.

Range and Offset are used to scale the reading to the proper units. The equation used is:

$$\text{Output} = \text{Reading} * \text{Range} + \text{Offset}$$

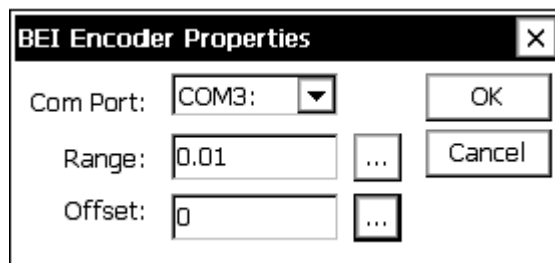

## Binary Input (BinIn)

### Inputs

<none>

### Outputs

BinOut

### Wiring

Signal: Any digital input channel

Ground: Any available ground

### Description

This is a general-purpose block for configuring a binary input hooked to a Digital I/O module. The *Channel* is one of the eight inputs available on the module (see Appendix C: I/O Modules).

A processing block such as Measure or Average is used to request data of this block, unless *Event* is checked. With *Event* checked, the output will update on change of state. Use “Edge” to determine which edge of the state change to trigger (Rising = Low → High, Falling = High → Low, Both = either direction).

The Filter parameter can be used to eliminate false state transition detections due to noise. The Filter value should be a number between 0 and 255. The higher the number, the longer the new state change must exist for the change to be seen by the digital I/O module. Each increment of the filter value represents about 0.5ms of time.

If this block is used in an EZSetup measurement with the *Event* checked, this will force ALL measurements to occur when an *Event* occurs. So, for example, if you had an EZSetup measurement schedule with the BinIn block and a sdi-12 sensor, every time the BinIn detected a change of state, the SDI-12 sensor would also be measured.

If *Invert* is checked, the output from this block will be the inverted value of what is seen at the channel (e.g., if the input is grounded, a binary 1 is output instead of a binary 0).

Input states are:

0V = binary 0

>2.5V = binary 1

**Binary Input Properties** [X]

Digital I/O Module: 1 [v] [OK]

Channel: 2 [v] [Cancel]

Invert Input

Event

Edge: Both [v]

Filter value: 0 [ ] [ ... ]



## Binary Input – All Channels (BinInAllChan)

### Inputs

<none>

### Outputs

DIOData

### Wiring

Signal: wire to all input channels defined in Bit Selection. Channels 1 – 6 have 100k internal pull-up resistors. Therefore, if open collector outputs are connected to channels 7 or 8, use an external pull-up resistor to +5V (prot +12 will also work).

Ground: any available ground

### Description

This block reads all bits defined in Bit Selection from a Digital I/O module and outputs the binary or gray code value the data represents. The block allows the user to select the I/O module, the number of bits, the coding, and whether or not the data needs to be inverted.

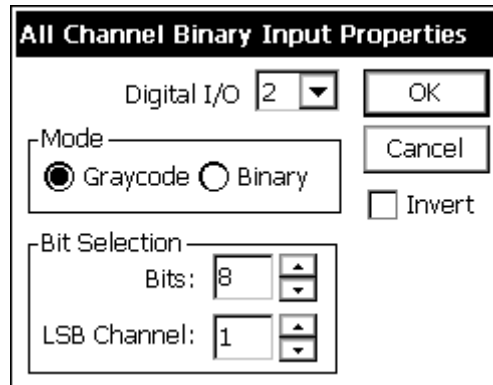

The coding options available are Binary and Graycode. Binary reads the input channels as binary bits, which it then converts to decimal (i.e.: LLLL HLHL = 0000 1010b = 10d). Graycode is a coding scheme where each sequential value only differs from its predecessor by one place. It is often used by absolute encoders so that slight misalignments between the reading elements will not result in widely incorrect readings. Notice, for example, that an increase from 3 to 4 causes two bits to change in binary but only one in Graycode:

Decimal	Binary	Greycode
0	000	000
1	001	001
2	010	011
3	011	010

4	100	110
5	101	111
6	110	101
7	111	100

The Bits value defines how many bits to convert, from six to eight. If less than eight bits are being converted, then set LSB Channel to the channel of the least significant bit.



## Bridge Resistance (Bridge)

### Inputs

<none>

### Outputs

Output

### Wiring

Wire to the Xpert as shown below. NOTE: DO NOT USE CHANNELS ABOVE 8 FOR EXCITATION

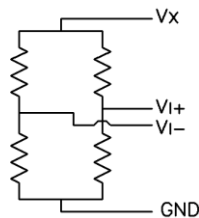

### Description

This block reads a bridge type resistance sensor. These sensors typically require an excitation of 2 to 5 volts and a full scale output of 10 to 100 mV. To make this measurement, the Xpert makes a single ended measurement of the reference voltage and a differential measurement of the input voltage. The equation applied to the measured voltages is as follows:

$$\text{Output} = \text{Slope} * V_i/V_x + \text{Offset.}$$

The user set properties of the Bridge block are shown below. Note that the input is a differential measurement so select an odd numbered input channel:



## CapRain (CapRain)

### Inputs

<none>

### Outputs

Rain

### Wiring

Connect the sensor output to the selected analog channel.

Connect the sensor power to PROT 12 (B17) and GND (B16 or =)

### Description

The CapRain block is designed to make measurements from an RM Young 50202 Capacitive Precipitation Gauge. It may also work with other rain gauges with an analog output. The RM Young 50202 sensor has an analog output (0-5 volts) corresponding to 0-50mm (0 to 2.5 inches) rain. The sensor automatically empties itself so the output will periodically go to zero.

The CapRain block has special processing designed to prevent measurements while the gauge is emptying the bucket. This processing takes two measurements of the gauge two seconds apart. If the output drops by more than 0.1 volts in this two-second interval the system sleeps for 5 seconds and then tries again. Up to six retries will be performed before the system logs an error. The block also has a special algorithm to accumulate the rain as though the bucket were not being emptied. If the current value measured has gone down by 1/5 of the range since the last measured value the software concludes that the gauge has emptied and adds 5\*slope to the sensor offset. The value reported by the block is always reading + offset.

***Note: You must get data from the CapRain block every 10 to 15 minutes so it can track the emptying. The maximum rain rate that can be handled by measurements every 10 minutes is 12 inches/hour and the maximum rate handled by measurements every 15 minutes is 8 inches/hour.***

The block supports the calibration to a use entered current value. When the calibration function is run, the system prompts for the current level. It then uses the current level and the current reading to automatically set the offset. The calibration function should not be done when the system is emptying the gauge or while the gauge output is changing.

Enter the slope in the units that you desire. The slope for inches would be  $0.5 = 2.5\text{inches}/5\text{volts}$ . The slope for mm would be  $10 = 50\text{mm}/5$ .

The offset should normally be 0 for a new site with an empty gauge. As explained above, the offset can also be computed to force the gauge to a specific value.

The units should be set to in or mm as determined by the slope.

**CapRain Properties** [X]

Analog I/O Module: 1 [v] [OK]

Input Channel: 7 [v] [Cancel]

Slope: 0.5 [ ] [...]

Offset: 0 [ ] [...]

Units: in [ ] [...]



## Constant (ConstIn)

### Inputs

<none>

### Outputs

Const

### Wiring

None

### Description

The constant block provides a constant value output. This can be valuable for testing setup diagrams before physical sensors are hooked-up, or in any other situation where a constant output is needed.

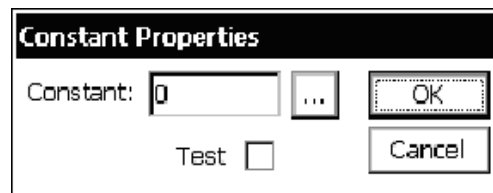

The *Test* check box is used to generate data that varies. This can be useful for system tests. When *Test* is checked the data will vary as follows:

Constant	Output
1	TickCount (ticks have units of milliseconds, not synchronized to any particular time)
2	Random Number between 1 and 32767
3	Output increases by 1
4	Output increases by 1 and delay 500 ms



## Counter (Counter)

### Inputs

<none>

### Outputs

Count

DeltaCount

Freq

### Wiring

Connect the device to the selected digital input.

### Description

The Counter block is a general-purpose block for measuring a counter or frequency input. Each time the block is run, it collects counter information from the digital I/O module and then computes a delta count and frequency from the data collected the last time the block was run. As a result, the first time this block is run, the frequency and delta count output will not have valid data.

Filter is used to debounce noisy inputs. Most mechanical switches, like a tipping bucket output, have noise, so a filter should be used with switches. A value of 0 specifies no debouncing while a value of 1 to 255 requires the input to remain high for  $\text{filter\_value} * 0.2$  ms in order for the system to register a count.

Along with computing the deltacounts and frequency, the block also scales the outputs according to the values of *Slope* and *Offset*.

The units for the outputs are forced to be Hz for Freq and CNT for Count and DeltaCount whenever the units are set to Hz. The user can change the units for all the outputs by changing the *Units* field on the property page to the desired value.

When *Reset Count* is checked, the count resets everytime recording is started. If the counter has been calibrated, it will reset to the calibrated value, otherwise, it will reset to zero. If more than one counter block, or tipping bucket block, is used on the same input channel, all blocks would be reset to zero.

The Counter block supports calibration from the Sensors tab. For the calibration, the user will enter the current value for the counter. The system will then compute a special calibration offset that is applied to the counter.

Anytime recording is stopped and restarted, the counter should be calibrated to a known state, as any counts that have ocured during the time when recording was stopped, have been missed.

**Counter Properties** [X]

Digital Mod: 1 [v] [OK]

Digital Chan: 2 [v] [Cancel]

Filter: 5 [ ] [...]

Slope: 1 [ ] [...]

Offset: 0 [ ] [...]

Units: Hz [ ] [...]

Reset count:



## CS107 Temperature Sensor (CS107Temp)

### Inputs

<none>

### Outputs

Temp

### Wiring

Connect the Thermistor black wire to the selected signal channel of the analog module CH1..CHxx

Connect a precision 100K 0.1% resistor between CHx above and the selected excitation channel CH1..CH8. NOTE: DO NOT USE CHANNELS ABOVE 8 FOR EXCITATION

Connect the Thermistor red to GND

Do not connect the purple AG to anything. Keep it insulated so it will not contact anything.

Connect the clear shield to GND.

### Description

This block measures a CS 107 temperature probe. The CS 107 uses a thermistor to measure temperature in air/soil or water over the range of -35 to +50C with an accuracy of about 0.5C.

The Xpert measures the CS107 using its special double voltage reading where it measures its excitation voltage in addition to the signal voltage. The nominal excitation voltage is 5 volts.

After making the measurement, the temperature is computed as follows:

$$R = VM*100000./(VX-VM)$$

Where R is the resistance of the thermistor, VM is the measured excitation voltage and VX is the measured signal voltage.

$X = 800000/(R)$  (this converts the resistance to a format compatible with the published conversion polynomial.

$$\text{Temp} = a + b*X + c*X^2 + d*X^3 + e*X^4 + f*X^5$$

Where:

Temp = temperature in degrees Celsius

a = -53.4601;b = 90.807;c = -83.257;d = 52.283;e = -16.723;f = 2.211

CS 107 Temperature

Analog I/O: 1

Exit. Chan: 1

Meas Chan: 2

Units:  F  C

OK

Cancel



## Frequency (Freq)

### Inputs

<none>

### Outputs

Freq

### Wiring

Connect the sensor frequency output to the selected CH1..CH8 of the digital module.

Connect the sensor GND to GND.

### Description

This block outputs the frequency of a digital input signal. First, select the Digital I/O Module and the channel number. Channels have a maximum frequency of 1KHz. The field *Multiplier* is normally left at one unless the cycles-per-second output of the frequency is to be changed. For example, to changing to cycles-per-minute, enter 0.0167 for this field.

The *Period* mostly has to do with when the block takes instantaneous (as opposed to continuous) frequency readings. For instantaneous readings, the Frequency block takes two time/count readings from the I/O module at *Period* time apart and used these to calculate the frequency of the signal. The longer the value entered for *Period* the greater the accuracy of the frequency (because of averaging) but the less “instantaneous” the reading will be.

When the frequency is being sampled frequently by a Measure or Average block, it might make sense to only take one time/count reading from the I/O module every pass, and calculate the frequency from the current and previous readings. For a sampling interval of 1 second, this would be the same as having the *Period* set to 1,000. If this is desired, un-check *Take Two Readings at a Time*, and set *Period* to 1,000. The Xpert will use the previous reading as long as it was taken within the time range of *Period* +/- *Period*/4 of the current time. Be careful how you set *Period* when *Take Two Readings* is unchecked. The smaller you make *Period*, the more likely the system will still take two measurements even though *Take Two Readings* is not checked. You should not make *Period* longer than the sampling interval of your measure or average block, or you will slow down data to the block. If you always want to use the previous reading to compute the frequency regardless of when it was measured, use the COUNTER block.

The block scales the outputs according to the values of *Slope* and *Offset* using the equation  $output = reading * slope + offset$ .

The user can change the units for all the outputs by changing the *Units* field to the desired value.

The block supports calibration from the Sensors page. For the calibration, the user will enter the current value. The system will then adjust the offset so the desired value is obtained.

**Frequency Properties** [X]

DIO Mod: 1 [v]      Slope: 1 [ ] [...]

Channel: 1 [v]      Offset: 0 [ ] [...]

Period (ms): 200 [ ] [...]      Units: Hz [ ] [...]

Take 2 readings:

[OK] [Cancel]



## Fuel Moisture (FM)

### Inputs

<none>

### Outputs

Fuel Moisture (FM)

### Wiring

Connect the FM signal ( to the selected input on the digital module (CH1)

Connect the FM enable to the selected input on the digital module (CH2)

Connect the GND to GND

Connect the FM Power to VBAT

Note: the digital module must have special code (part number 8080-0006-1).

### Description

This block measures a CS505 Fuel Moisture sensor. The sensor has an output frequency in the range of 600 to 1500 Hz. A special version of the digital module 8080-0006-1 is needed to read these higher frequencies. The sensor also has a separate enable line to turn on and off the sensor as needed to make a measurement.

The equation used to convert the frequency to fuel moisture (percent) is as follows:

$$PP = (1 / \text{Freq}) * 1000$$

$$FM = C0 + C1*PP + C2*PP*PP$$

$$C0 = -220.14$$

$$C1 = 365.89$$

$$C2 = -114.96$$

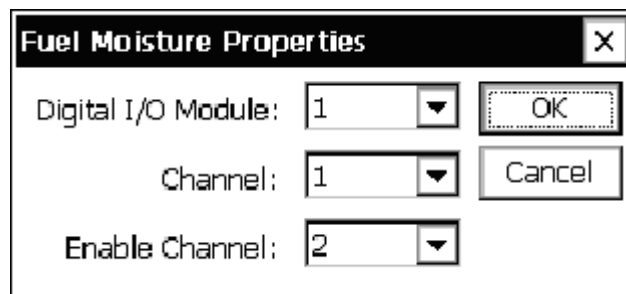



## GetTag

### Inputs

### Outputs

Data

### Description

This block gets the requested data from another station using Sutron Standard Protocol (SSP) communications. The properties for the block specify the port to use for the communications and the path or station name. The port can only be specified if you have first used the Setup tab COMS control and defined some communications ports. The path can be a simple station name or a station with full path information included (such as `\patha\pathb\stationx`).

The Tag property must match the name specified in a COMS Tag in the named station. For example, Station 1 is measuring water level and Station 2 wants to get the water level for its own use. Add a COMS Tag after the measure of the water level in Station 1. Set the COMS TAG *Name* property as WL. In Station 2, add a GETTAG sensor connected to a measure. In the GETTAG properties, set the *Tag* property to WL. Also set the port and path for the link between the two stations. Now whenever GETTAG runs, the code will communicate to the named station and ask for WL. The station will reply with the data for WL and then the GETTAG block will provide the data to connected blocks.

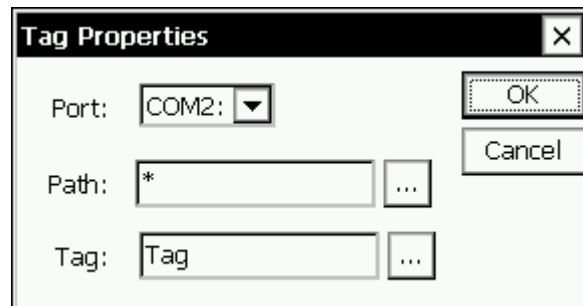



## GillWind (Gill Wind Sensor)

### Inputs

<none>

### Outputs

WindSpeed

WindDirection

### Wiring

Connect the sensor to a RS232 port as follows (wiring is shown for the 6461-1239 protection board):

Connector	Name	Pin (6461-1239)
2 V+	+12	6
5 TXD	RXD	2
7 RXD	TXD	3
1 GND, 3 V-	GND	5

Note: Set jumper J3 on the 6461-1239 to DTR

Configure Xpert for +12 on pin 9 of the DB9.

Gill sensor must be set up as follows:

M4, U3, O1, L1, P2, B3, F1, H1, HQ, E1, T1, S3, C1

### Description

This block supports the Gill WindSonic ultrasonic wind sensor. This sensor has an RS232 serial output that can connect to one of the serial ports. The WindSonic has its own configuration and setup. The user must make sure the WindObserverII is setup to operate with the Xpert before connecting it, as it will not alter the setup of the sensor.

In setting up the sensor, the user can choose the output units, heater control and node address etc. The user must set the sensor block's "node address" property to the same address as the sensor.

The user must set the sensor as follows (see the Gill manual for further details):

Establish a connection from the sensor to a PC and turn on power to the sensor.

Enter configuration mode by sending \* if the sensor is in continuous output mode, or sending \*<node> if the sensor is in polling mode.

Send D3<CR> to display the current configuration.

Set the sensors to the following parameters (the manual explains how to do this):

WindSonic: M4,O1,L1,P1,B3,F1,H2,E1.

Set the units as desired with U, the heating with H, and the node address with N.

Send Q<CR> (Q is for Quit) when finished.

The setup of the Xpert to read the WindSonic is much easier. Simply specify the com port the sensor is connected to, the power setting and the address. **NOTE:** Leave the settings in the SETUP TAB/ COMS set to none, as this block will not be able to use the com port if coms is already using it.

The Xpert will output the data in whatever units are set in the WindSonic.

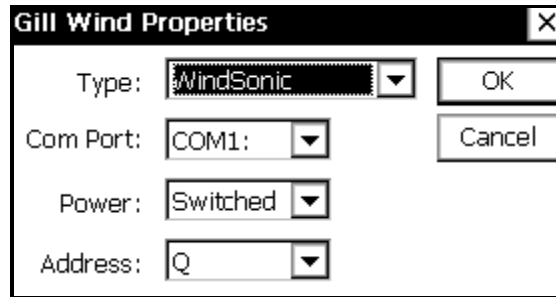



## Internal Battery (IntBat)

### Inputs

<none>

### Outputs

Battery

Temp

### Wiring

None, the sensors are internal to the Xpert.

### Description

This block measures supply voltage and internal temperature. The temperature measurement is accurate to within  $\pm 3$  deg Celsius.

**Note: the temperature measurement is that of the internal PC board, not air temperature.**

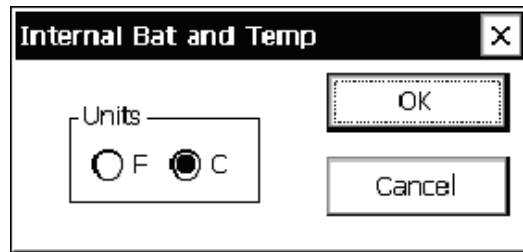



## Log Input

### Inputs

<none>

### Outputs

LogVal: the value retrieved from the log

### Wiring

None.

### Description

This block retrieves the last value from the log for the sensor indicated. This block is most useful when data is logged by EzSetup or an Xpert Basic program, but needs to be processed in the Graphical Setup. When scheduling this block, be sure to schedule it so that it runs *after* the desired data is logged.

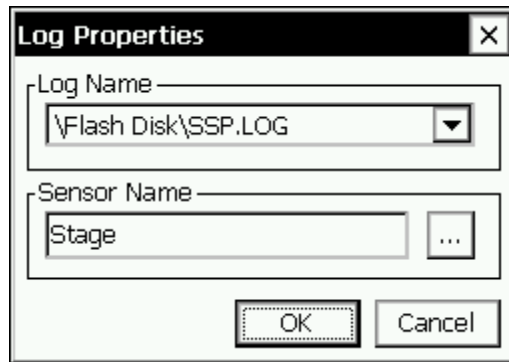



## MRL 700 Radar Sensor (MRL700)

### Inputs

<none>

### Outputs

dist

level

sigstr

### Wiring and Configuration

**NOTE: To use this block with the Xpert, one of the RS-232 com ports must be changed out for an optional RS-485 board (6461-1251-1T). Set the jumper for +12 volts(J3 to pins 2-3) to use power from this board.**

Connect the sensor RS485 A to the RS485A (pin 3) and the sensor B to the RS485B (pin 2).  
NOTE: Leave the settings in the SETUP TAB/ COMS set to none, as this block will not be able to use the com port if coms is already using it.

The sensor must be configured to output in the following format: distance, signal strength with 9600 baud, 7bit, even parity, one stop bit. Configure the sensor to output 0.00 if it loses signal. For more information see the 8800-1146 MRL users manual.

Connect Power leads as configured below, either to GND and SW'D 12 (for AIO sw or DIO sw), or through a relay that is switching the battery and using the selected DIO channel for control.

### Description

The MRL700 is used for measuring distance and, therefore, level. The properties dialog is used to specify configuration details required for proper operation.

“Reference” is used to specify the reference distance and is used to compute level.

“Warmup” is the number of seconds the unit should be powered on before taking a measurement. A typical warmup value is 30 seconds, this is the time the sensor needs to provide back reliable readings. If the values are to be averaged, make sure to set the average time to at least two times this warmup time (I.E. For 30 seconds of warmup the sensor should be averaged for at least one minute)

“Inactivity” is the number of seconds the unit should remain powered on following a measurement. This prevents the sensor from having to go through the warmup time for every reading I.E. If averaging every 5 seconds, setting this inactivity timer to 10 seconds, will keep power on between readings.

“PwrCtl” is used to specify how the sensor is to be powered on. When set to “DIO Sw”, DIO switched-12 is used to control power. When set to “AIO Sw”, AIO switched-12 is used to control power to the sensor. (On the Xlite, of course, AIO and DIO switched-12 are the same

thing). When set to “DIO Chan”, the module and channel fields are used to determine the digital output used to control power to the sensor.

“Module” and “Channel” are used to designate the IO module used to control power to the sensor (Channel is applicable only when PwrCtrl is set to DIO Chan).

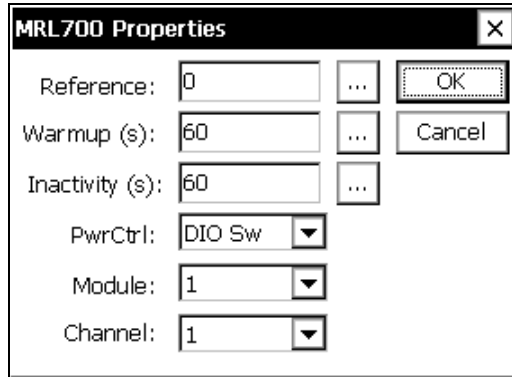

A typical averaging setup (using Ezsetup) would be as follows:

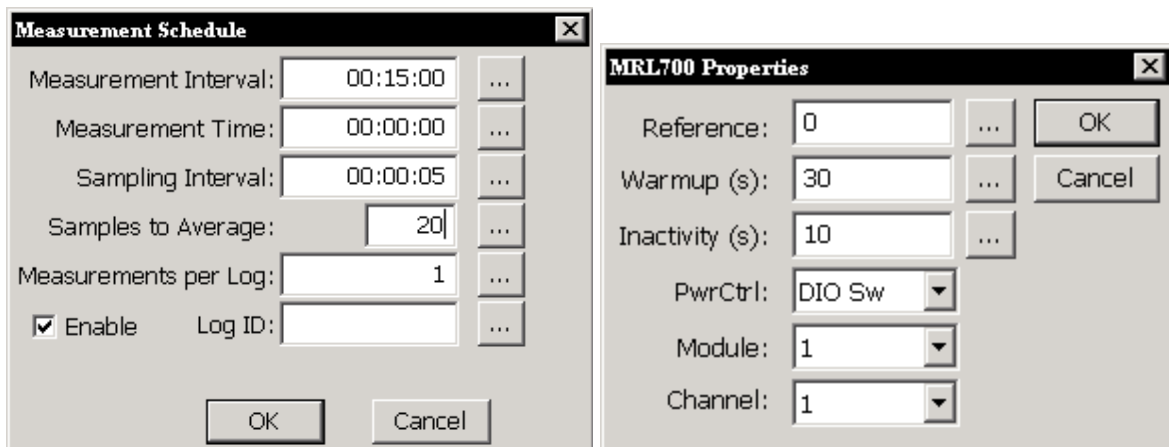

Using the measurement time starting at 00:00:00 and a 00:15:00 interval. will log the data with a timestamp at 00:01:35,00:16:35.....23:46:35.



## Platinum RTD (PlatRTD)

### Inputs

<none>

### Outputs

PlatRTD

### Wiring

Connect the sensor to channels 1,2; 3,4; etc. as selected for a differential measurement. Connect the sensor as shown below.

NOTE: DO NOT USE CHANNELS ABOVE 8 FOR EXCITATION

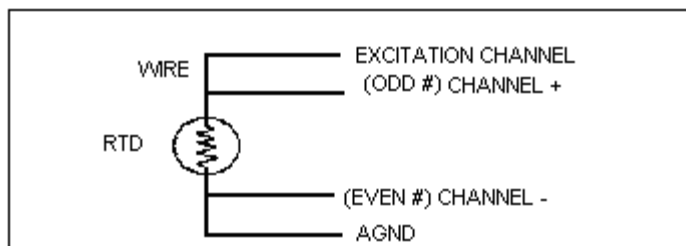

**4-wire mode**

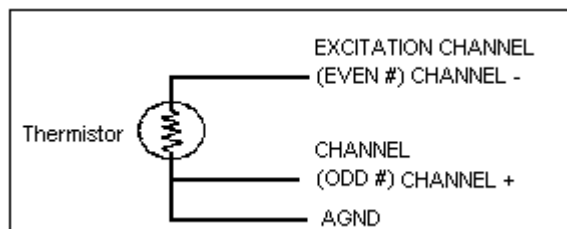

**3-Wire Mode**

### Description

The Platinum RTD block is used for measuring a 100 ohm platinum temperature devices. The dialog allows the selection of the block channel and excitation. The type is also selectable between 385 and 392 type devices. The resistance at zero degrees can be set for calibration purposes. The system will do a differential measurement so always select an odd channel number (1, 3, 5...).

In 3-wire mode, set the “Channel” to the odd # channel (e.g. 1, 3, 5) and “Excitation Ch” to the even channel pair (e.g. if "Channel" is 1, then “Excitation Ch” is 2, if "Channel" is 3 then “Excitation Ch” is 4, etc.).

Note: high resolution readings will take longer than non-high resolution readings.

**Platinum RTD Properties** [X]

AIO module: 1 [v]  
Input channel: 1 [v]  
Excit channel: 2 [v]

Units:  F  C  
Type:  385  392

3-wire mode:  Hi resolution:

Ohms @ 0 C: 100 [ ] ... [ ]

OK Cancel



## Quadrature Shaft Encoder

### Inputs

<none>

### Outputs

Level

### Wiring

Wire the pair of quadrature outputs to digital channels 1 and 2, 3 and 4, 5 and 6, or 7 and 8. If counts are in the wrong direction, either reverse wires or change the rotation setting in the properties.

Power the sensor off +12V and GND.

### Description

This block is used to collect data from an incremental/quadrature shaft encoder through a Digital I/O Module. Up to four Quadrature shaft encoders may be set up on one module. The signal lines from each encoder must hook-up to adjacent I/O module inputs starting with an odd-numbered one (i.e.: 1,2; 3,4; 5,6; or 7,8).

Select the module and channel pair number the encoder is hooked-up to (odd channel - 3, 5 or 7). Enter the wheel diameter, the rotation direction that results in a positive increase to the output, and the units for the block to output in. The Counts per Turn drop down box allows you to select 100, 256, 400 and 800 counts per turn in order to support different shaft encoders.

The quadrature shaft encoder block contains a calibrate procedure. The calibrate procedure is used to set the reading to a user set value. This is important to do whenever the Xpert is restarted or maintenance is done on the sensor. The calibration procedure is run from the Sensors tab.

The image shows a dialog box titled "Quadrature Shaft Encoder Properties". It contains the following fields and controls:

- DIO Module: 1 (dropdown menu)
- Channel: 3 (dropdown menu)
- Wheel Circumference: 1 Foot (dropdown menu)
- Other Circumference: 1 (text input field)
- Counts per Turn: 100 (dropdown menu)
- Rotation: CW (radio button selected), CCW (radio button)
- Units: ft (radio button selected), m (radio button)

Buttons for "OK" and "Cancel" are located to the right of the DIO Module and Channel fields respectively.



## R.M. Young Wind Sensor (RMYoung)

### Inputs

<none>

### Outputs

Speed

Dir

### Wiring

#### Wind Direction

AZEXC	Connect to selected excitation channel on the analog module (V <sub>x</sub> ) NOTE: DO NOT USE CHANNELS ABOVE 8 FOR EXCITATION
AZSIG	Connect to selected input channel on the analog module (V <sub>i</sub> ).
REF	Connect to GND

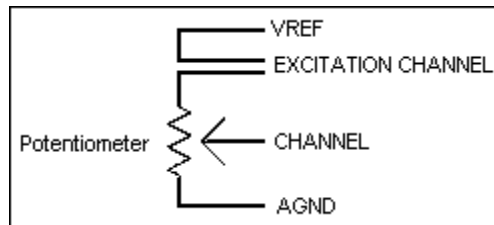

#### Powered Sensors

WS Sig connect to selected input channel (CH1..CH6) of digital module. Note CH7 and CH8 reserved for non-powered sensors with low level outputs.

V+ Supply connect to VBAT

REF connect to GND

#### Non-Powered Sensors

WS Sig connect to digital CH7 or CH8 of digital module

Note: The direction potentiometer of most models of the RM Young wind sensor has a 5 degree electrical open from 355 to 360 degrees. A one megohm resistor can be placed from the AZSIG (input channel) to AZEXC (excitation channel) or AGND to define the direction as 355 degrees (AZEXC) or 0 degrees (AGND) in the open region.

## Description

This block is designed to make measurements from an R.M. Young wind sensor, models 5103 or 5305. One analog input and one excitation channel (analog output) is needed on an Analog I/O module to determine wind direction. Wind direction requires connection to Digital Module input channel. The units for wind speed can be set to mph, mps, kph, ftps, or knots.

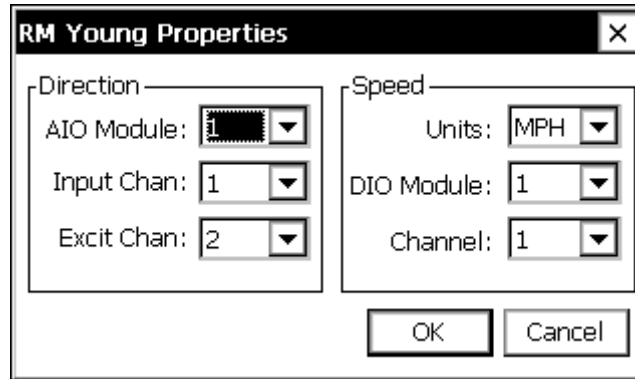

The image shows a dialog box titled "RM Young Properties" with a close button (X) in the top right corner. The dialog is divided into two main sections: "Direction" and "Speed".

**Direction Section:**

- AIO Module: 1 (dropdown menu)
- Input Chan: 1 (dropdown menu)
- Excit Chan: 2 (dropdown menu)

**Speed Section:**

- Units: MPH (dropdown menu)
- DIO Module: 1 (dropdown menu)
- Channel: 1 (dropdown menu)

At the bottom of the dialog are two buttons: "OK" and "Cancel".

## **SDI 12** SDI-12

### **Inputs**

<none>

### **Outputs**

Output 0

...

Output 19

### **Wiring**

All SDI-12 sensors wire to GND, +12 and Data on the Xpert. Multiple wires can be connected to the same connections.

### **Description**

This general purpose sensor block is used to obtain data from a SDI-12 sensor. Select the SDI-12 address of the sensor, the measurement command type\* and the units to report with the reading. The C (concurrent measurement) command is only supported by SDI sensors versions 1.3 and higher.

*\*NOTE: The only supported commands are V, M, MC, M1 - M9, C, CC, C1 - C9. To get other types of measurements, a basic program using the SDI function must be used (SdiCollect does not work, so data must be parsed by the program).*

The block scales the outputs according to the values of *Slope* and *Offset* using the equation  $output = reading * slope + offset$ .

The user can change the units for all the outputs by changing the *Units* field to the desired value.

The block supports calibration from the Sensors page. For the calibration, the user will enter the current value sensor. The system will then adjust the offset so the desired value is obtained.

SDI Properties

Address: 0 [v] [OK]

Command: M [...] [Cancel]

Slope: 1 [...]

Offset: 0 [...]

Units: [...] [...]



## SDI AquaTrak (SDIAqua)

### Inputs

<none>

### Outputs

Average

Std

Outliers

Cals

Quality

### Wiring

SDI-12 port

### Description

The SDI AquaTrak block is designed to operate with the AquaTrak 4100 series controller and sensor heads for measuring water level. The AquaTrak sensor must be configured separately to specify the measurement modes and desired averaging algorithm and number of samples to take. The typical configuration uses the NOS DQAP algorithm measuring 181 samples.

Once configured, the Xpert will make measurements using the standard SDI M command or C command, if Concurrent is selected.

Testing has shown that the AquaTrak controller tends to ignore the retries that come very quickly as part of the normal SDI-12 retry process. Hence, this block performs an additional retry after the user-specified Retry Delay. This delay should be set to 2000 minimally when Concurrent is selected, and set to 3000 minimally when Concurrent is not selected.

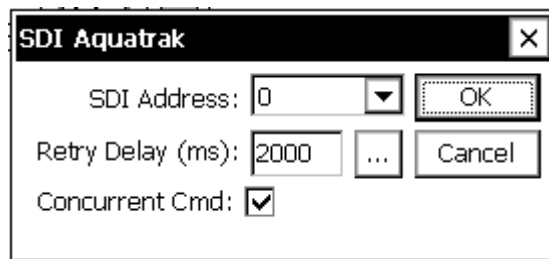



## SE8500 (SE8500)

### Inputs

<none>

### Outputs

Output

### Wiring

The SE8500 can connect to any of the Xpert serial ports. The SE8500 wires to the 6461-1239 termination board as follows:

Color	Name	Pin (6461-1239)
Red	+12	6
BLK	GND	5
White	TXD	3
Green	RXD	2

### Description

This block measures a SE8500 configured for serial output. It can also work with an SE8500 connected to a wireless link. The properties allow setting the Com Port, range, offset, address and units. **NOTE:** Leave the settings in the SETUP TAB/ COMS set to none, as this block will not be able to use the com port if coms is already using it. Address specifies which address the SE8500 is set to. Typically address is 0. Other valid addresses are 1..9, A..F.

After the value is read from the SE8500 it is scaled as follows:

$$\text{Value} = \text{reading} * \text{range} + \text{offset}.$$

Range is typically 0.01 because the SE8500 multiples its value by 100 before sending it. However, you can select a different range value if desired.

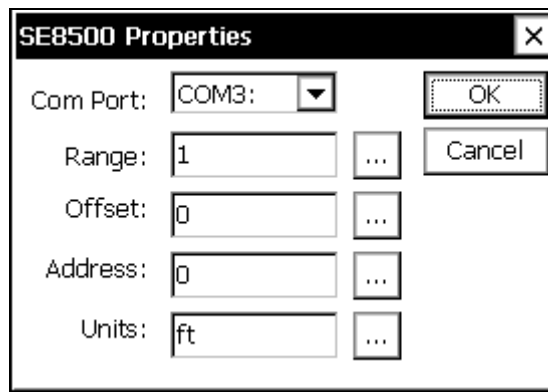



## Send Current Time (SendTime)

### Inputs

<none>

### Outputs

<none>

### Description

This block is used to synchronize the system time of connected units that “speak” SSP (i.e., other 9210s, Xperts, 8210s, etc.). This block sends an SSP “set-time” message containing the current system time to the destination unit(s) specified by the “Path” property. The message is sent periodically according to the scheduling parameters “Time” and “Interval”.

To broadcast the set time message to all listeners, set the “Path” property to “\*”. Otherwise, enter a specific station name or station path (e.g., *\patha\pathb\stationx*).

Set the “Port” property to the communications port to which the other device(s) is(are) connected. This com port must already be defined in the Setup tab under COMS.

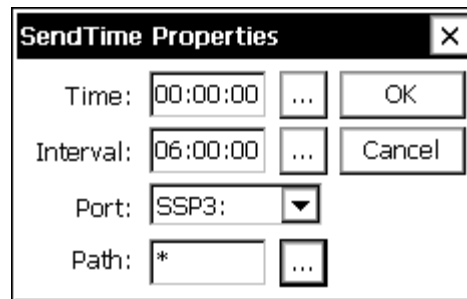

## **Soil Mstr** Soil Moisture (SoilM)

### **Inputs**

<none>

### **Outputs**

Dielectric

Moisture

Temp

### **Wiring**

Connect the sensor output (green) to the selected channel on the analog module.

If the Type is moisture+temperature, connect the temperature output (blue) to the next higher channel.

Connect the sensor ground (white) to GND

Connect the sensor power (red) to SW'D 12V.

### **Description**

This block supports Sutron's 5600-0089 soil moisture/temperature sensor. The type box supports the following:

Moisture	measure moisture only
Moisture+temperature	measure moisture and temperature on a separate channel
Moisture+temp muxed	measure moisture, wait 5 seconds, then measure temperature on the same channel

The "use digital" check box allows you to specify a digital channel to enable individual sensors (see page 8 of the sensor manual for more details).

The cable correct check box directs the software to apply the cable offset correction as explained on page 12-13 of the sensor manual.

**Soil Moisture Properties** [X]

Type: moisture [v] [OK]

Analog Mod: 1 [v] [Cancel]

Analog Chan: 1 [v]

Use Digital:

Digital Mod: 1 [v]

Digital Chan: 1 [v]

Cable Correct:  Length: 111 [v]



## Solar Radiation (SolRad)

### Inputs

<none>

### Outputs

SolRad

### Wiring

Connect the sensor output to the selected channel on the analog module CH1..CH6

Connect the sensor ground to GND.

### Description

This block supports all the solar radiation sensor sold by Sutron, part numbers 5600-0600, -0601, -0602, -0603, and -0604. All of these utilize one channel (analog input) on an Analog I/O module. Select the sensor part number and the units for the block to output in. The *Calibration* is used in the equation:

Solar Radiation = mv/calibration.

The units for *Calibration* are typically millivolts per watt per meter squared. The sensor manufacturer typically supplies the value for calibration. If the units supplied by the manufacturer are in a different format, convert them prior to entering the calibration value.

Specify in "Warmup (ms)" the number of milliseconds the I/O module should wait before taking the measurement. This wait time allows the module to settle in order to make an accurate measurement.

The screenshot shows a dialog box titled "Solar Radiation" with a close button (X) in the top right corner. The dialog contains the following fields and controls:

- Analog I/O Module: A dropdown menu showing "1" and an "OK" button.
- Channel: A dropdown menu showing "3" and a "Cancel" button.
- Units: A text box containing "W/m2" and an ellipsis button "...".
- Calibration: A text box containing "1" and an ellipsis button "...".
- Warmup (ms): A text box containing "100" and an ellipsis button "...".
- Gain Selection: Three radio buttons labeled "Normal Gain" (selected), "Hi Gain", and "x128 Gain".

With the exception of the 5600-0604, the Hi Gain setting is typically used for solar radiation sensors. It is possible to use the x128 setting if the expected range of irradiance is low enough to ensure that the output voltage will be less than 19 mV, but due to the high resolution of the analog to digital converters used, there is rarely a need for the x128 range.

When using Hi Gain, the input voltage should be less than 312mV when using the 8080-0003 Analog I/O Module, and less than 78mV when using the 8080-0007 Analog I/O Module. When using x128 Gain, the input voltage should be less than 39mV when using the 8080-0003 Analog I/O Module, and less than 19mV when using the 8080-0007 Analog I/O Module.

See the table below for the voltage ranges of Sutron Solar Radiation sensors. A check “√” in a gain column means the selected gain is appropriate for that sensor. An “x” in a gain column, means the selected gain is not appropriate for that sensor.

Part Number	Max Output	Normal Gain	Hi Gain	x128 Gain
5600-0600	Typ. 40 mV @ 3000 W m <sup>-2</sup>	x	√	√
5600-0601	30 mV @ 2000 W m <sup>-2</sup>	x	√	√
5600-0602	Typ. 25 mV @ 2800 W m <sup>-2</sup>	x	√	√
5600-0603	Typ. 30 mV @ 10,000 μmol s <sup>-1</sup> m <sup>-2</sup>	x	√	√
5600-0604	Typ. 200 mV @ 2000 W m <sup>-2</sup>	√	√*	x
5600-0605	70mV @ 2000 W m <sup>-2</sup>	x	√	√

\* - Acceptable only when measured using 8080-0003 Analog I/O module.



## Submersible Pressure Transducer (SubPres)

### Inputs

<none>

### Outputs

PressEng

### Wiring

Wire to SDI-12 port

### Description

This block supports the Sutron 56-109 Submersible Pressure Transducer. This SDI-12 sensor is used to measure water level or pressure in well or surface water applications. The averaging time can be used to increase the measurement accuracy by lengthening the sampling time, and/or for situations where there are waves on the water surface. Unit options are ft, PSI, kPa, m, cm, or mm.

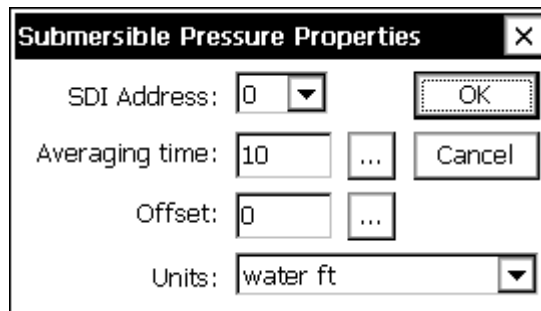

## **T<sub>B</sub>** Tipping Bucket Sensor (Precip)

### Inputs

<none>

### Outputs

Precip

### Wiring

Connect one side of the tipping bucket switch to the selected digital channel.

Connect the other wire to GND.

### Description

This block works with reed, wetted reed, and magnetic tipping buckets. The tipping bucket output hooks to one input of a Digital I/O module. Set *Tip* to the amount of rainfall associated with one bucket tip. The supported Tips are 0.1mm, 0.2mm, 0.25mm, 0.3mm, 0.5mm, 1.0mm, 0.01", and 0.008". *Filter* can be increased to eliminate extra readings due to bucket bounce; however, the default value should suffice for most units. The output of this block is the total amount of rain that has fallen since sampling began.

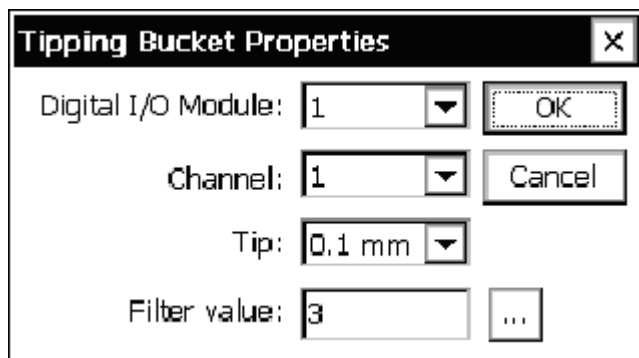

The tipping bucket block contains a calibrate procedure. The calibrate procedure is used to set the reading to a user set value, or to run a calibration test. This is important to do whenever the Xpert is restarted. The calibration procedure is run from the Sensors tab, Calibrate button.

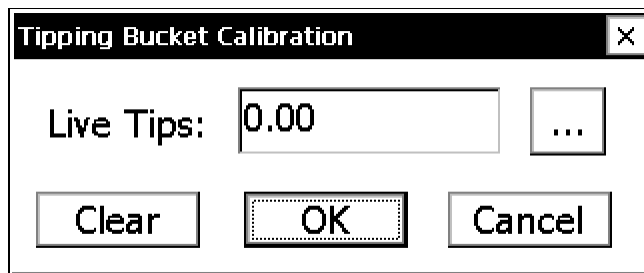

When the calibration is entered, the old value of the tipping bucket is preserved and is “locked”. This means that if recording is still on and the system measures or logs the tipping bucket, the old value is used. The “Live Tips” display always starts out initially at zero and updates very rapidly. It will increment as the tipping bucket tips. You may enter a new value by pressing the [...] button. To restore the old value and return to normal operations at any time just press the cancel button. To accept the displayed value and make it become the new value, press the OK button.

To test the tipping bucket, enter the calibration screen, add a specific amount of water to the tipping bucket, and observe the read-out. Press cancel when done.

To correct the tipping bucket, enter the calibration screen, press the [...] button, and enter the correct value. Press ok when done.



## Volt Meter (VoltMeter)

### Inputs

<none>

### Outputs

AIOVolt

### Wiring

Connect the voltage output to the analog channel selected CH1..CH6.

Connect a ground from the sensor to GND

### Description

VoltMeter is a general-purpose block for measuring a voltage from an Analog I/O module analog input. User selections are available for the I/O module and channel (analog input), warm-up time, slope, offset and reported units.

The formula for calculating the reading is:  $Output = V_{in} * Slope + Offset$

Default units is "volts", this may be changed to match desired reading (I.E. "Degrees C").

The *Settling Time (Warm Up)* can be adjusted to adapt either to long sensor signal settling times, or to give the voltage reference in the Analog I/O Module a longer time to warm-up for increased converting accuracy.

The block scales the outputs according to the values of *Slope* and *Offset* using the equation  $output = reading * slope + offset$ .

The user can change the units for all the outputs by changing the *Units* field to the desired value.

The block supports calibration from the Sensors page. For the calibration, the user will enter the current value sensor. The system will then adjust the offset so the desired value is obtained.

**Voltmeter (DC) Properties** [X]

Analog I/O Module: 1 [v] [OK]

Channel: 2 [v] [Cancel]

Settling Time (ms): 100 [...]

Slope: 1 [...]

Offset: 0 [...]

Units: Volts [...]

HiGain:

# PROCESSING BLOCKS

---



## Alarm

### Inputs

Input

### Outputs

Hi Alarm – True (1) if the data is in Hi Alarm, otherwise false (0)

Lo Alarm – True (1) if the data is in Lo Alarm, otherwise false (0)

Data – pass through of the data

ROC Alarm – True (1) if the data is in ROC Alarm, otherwise false (0)

Any Alarm – True (1) if the data is in any alarm, otherwise false (0)

### Description

The Alarm block checks the input data for alarms. The Alarm Properties allow the Alarm block to be configured to detect Hi Alarms, Lo Alarms and ROC Alarms. The same deadband applies to all types of alarms.

The Alarm block is also used to configure the unit to send out ALERTS. See the following chart for details:

HI Mode and LOW Mode	OFF	Do not send out an alert, only go into alarm.
	ABOVE	Send an alert when the value goes above the HI limit + deadband
	BELOW	Send an alert when the value goes below the HI limit - deadband
	BOTH	Send an alert when the value goes above the HI limit + deadband OR when the value goes below the HI limit - deadband
Alert on ROC Alarm	Checked	Send an alert based on the ROC mode. Above or Below.
	UNChecked	Do not send out an alert.

Alerts will only occur when the conditions set above are met, and will continue until acknowledged. Once an alert has occurred, the unit will stay in alarm until the conditions are no longer met. Certain devices under the COMS menu can have alert disabled, see the section under COMS for more information. If the unit is configured under the COMS menu to send data at an ALARM interval (anything other than 00:00:00) the unit will continue sending out that data.

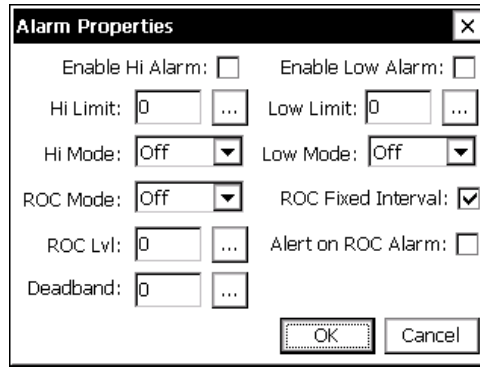

Hi Alarm	Go into alarm if the input value is $> \text{Hi Limit} + \text{deadband}$
	Go out of alarm if the input value is $< \text{Hi Limit} - \text{deadband}$
Low Alarm	Go into alarm if the input value is $< \text{Low Limit} - \text{deadband}$
	Go out of alarm if the input value is $> \text{Low Limit} + \text{deadband}$
Rate Of Change Alarm	<p>1. When ROC Mode is set to Off, no ROC alarm test occurs.</p> <p>2. When ROC Mode is set to Hi, the system goes into alarm if the change in input value is <math>&gt; \text{ROC Mag} + \text{deadband}</math>. The system goes out of alarm when the change in input value is <math>&lt; \text{ROC Mag} - \text{deadband}</math>.</p> <p>3. When ROC Mode is set to Low, the system goes into alarm if the change in input value is <math>&lt; \text{ROC Mag} - \text{deadband}</math>. The system goes out of alarm when the change in input value is <math>&gt; \text{ROC Mag} + \text{deadband}</math>.</p> <p>4. The change in input value is computed in one of two ways, depending on the state of Fixed Interval. If Fixed Interval is checked, the change in input is calculated as the absolute value of the difference between the current value and the last value.</p> <p>If Fixed Interval is not checked, the change in input is calculated as the absolute value of the difference between the current value and the last value that caused a ROC Alarm to occur. Since no alarm has occurred on the start of recording, the first reading taken after the press of START recording (Or power up) is used as the basis to determine ROC alarm, once the unit goes into alarm, the alarm value becomes the basis for the next alarm.</p>



## Accumulator (Accum)

### Inputs

Data

Enable

### Outputs

TAccum – Trigger accumulation. Output when the running accumulation surpasses the threshold value.

Accum – Accumulation since last scheduled reset.

Trigger – Trigger. Output set to 1 when the running accumulation surpasses the threshold value.

PTotal – Previous total which is value of accumulation at scheduled reset.

### Description

The Accum block is used to accumulate input data and to set outputs based on the current accumulation. This block is typically used as a part of a system to monitor and control a water sampler where blocks before the accumulator measure level and flow, compute discharge, and compute discharge\*time. This block then accumulates the total flow and sets a trigger every time a selected amount of flow has been registered. The total flow is reset to 0 at a user set schedule, typically daily. The trigger typically connects to a pulse output block.

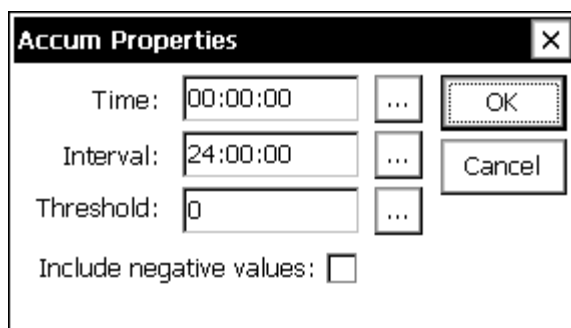

Use the *Time* and *Interval* properties to set the schedule at which the block resets the accumulation.

Use the *Threshold* property to specify the value of accumulation that, when reached, is a signal to set the trigger output to 1.

Check “Include negative values” to allow negative input values to be included in the accumulation. When not checked, negative input values are not included.



## Average (Average)

### Inputs

Input

### Outputs

Average – Computes the mean average of the samples taken during the *Duration*.

Min – Outputs the minimum of the samples taken during the *Duration*.

Max – Outputs the maximum of the samples taken during the *Duration*.

STD – Computes the standard deviation of the samples taken during the *Duration*.

Count – Outputs the number of samples that were used to compute the average.

### Description

The Average block is like a Measure block that can perform some common data processing functions related to averaging. The block can output the average (mean), maximum, minimum, standard deviation, or sample count (number of samples) from a series of data points sampled from a sensor.

The *Schedule Interval* indicates how often the Average block should sample a series of data points, process them, and output a value. The *Schedule Time* specifies the synchronization of when this should begin. The *Sample Interval* entry indicates how often the sensor should be sampled each time its scheduled to sample and the *Sample Duration* specifies for how long. To average continuously, the *Schedule Interval* should be set equal to the *Sample Duration*.

Note: *Sample Interval* may be set to milliseconds for sub-second sampling. For example, the value 00:00:00:500 would cause sampling to occur every 500 milliseconds. When specifying milliseconds, you must specify all three digits.

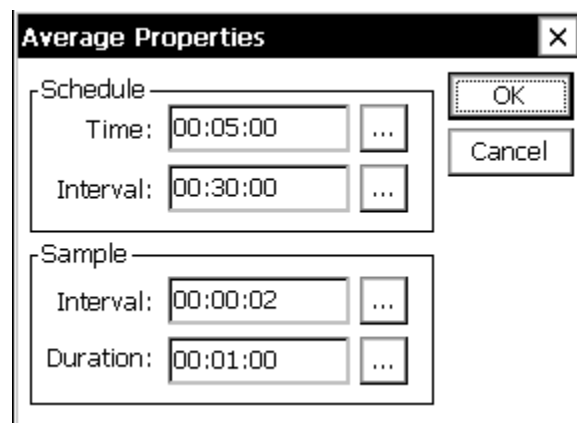

The example above shows an Average block that will perform its averaging every 30 minutes, starting at an offset of 5 minutes from the hour. When averaging starts, samples will be taken every 2 seconds, for a duration of 1 minute. At the time of the last sample, all the

block's outputs (mean, min, max, etc.) are computed and are output. Note: **the timestamp assigned to all the output data is the time of the last sample.** In the example above, the timestamp for the averaging period started at 12:35:00 would be 12:35:58.



## Bool (Boolean)

### Inputs

X

Y

### Outputs

Output

### Description

The Boolean block is used to perform boolean operations on the two inputs, X and Y, and output the result in Output. Non-zero data values are considered “true”. A “true” output is assigned the value of 1.

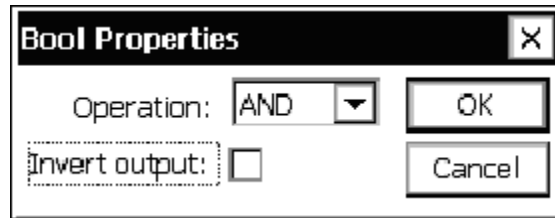

The *Operation* property can be set to one of “AND”, “OR”, or “XOR”. The table below defines the output given all the possible different inputs and operations.

Inputs		Output		
X	Y	AND	OR	XOR
true	true	true	true	false
true	false	false	true	true
false	true	false	true	true
false	false	false	false	false

When the *Invert Output* check box is selected, the outputs shown in the table are inverted.



## Dew Point (DewPt)

### Inputs

temperature

humidity

### Outputs

dew point

### Description

This block computes dew point from temperature and humidity. The temperature input may have units of either celsius or fahrenheit (the units field of the incoming data is used to determine which is in effect). The humidity input is expected to be a percentage.

The dew point output is expressed in the same units as the incoming temperature.

The block has no user-set properties. Dew point is computed according to the “WMO Guide to Meteorological Instruments and Methods Observation” WMO-No.8 seventh edition, 2006.



## DQAP (Quality-Controlled Average)

### Inputs

Input

### Outputs

**Average** – Computes the quality-controlled average (mean value) of the samples taken during the *Duration*.

**STD** – Computes the quality-controlled standard deviation of the samples taken during the *Duration*.

**Count** – Outputs the number of samples that were collected. (The number of samples used in the output average is the Count minus the Outliers)

**Outliers** – Outputs the number of samples that were greater than three standard deviations from the initial sample mean.

### Description

The DQAP block is a special modification of the Average block. The Average block is a Measure block that can output the maximum, minimum, average, standard deviation, and sample count from a series of data points sampled from a sensor. The DQAP block also computes the average, and outputs it along with the standard deviation and sample count. The difference is in the way the average and standard deviation are computed.

The DQAP block makes use of statistical quality control theory to improve the accuracy of the reported mean and standard deviation. The improvement is obtained by computing the mean and standard deviation in two passes. In the first pass, the mean and standard deviation are determined by the usual process of simply using the collected samples “as is”. After the standard deviation is computed a second pass is made. In the second pass, before a sample is added to a sum, or squared and added to a sum of squares, it is compared to the mean plus or minus three standard deviations. Quality Control (QC) theory indicates that such samples are likely to be in error. An updated mean and standard deviation are computed using only the samples that pass the QC check.

The DQAP block is used to periodically take a number of samples from a sensor and then output the quality-controlled mean, standard deviation, sample count, and number of samples failing the QC check. For example, every half an hour, with a five minute offset, a sensor could be sampled every two seconds for thirty seconds and then the maximum value sampled outputted (see example below).

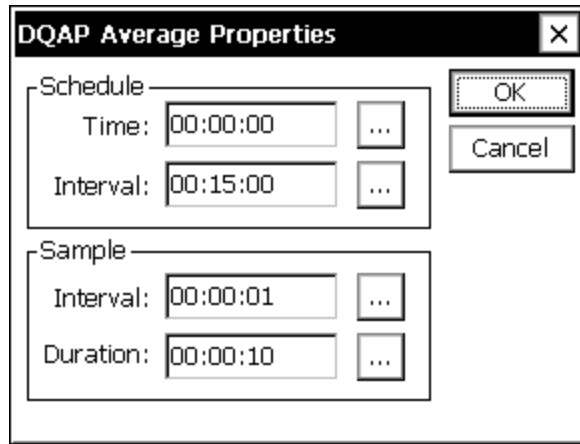

Specifically, the *Schedule Interval* indicates how often the DQAP block should sample a series of data points, process them, and output values. The *Schedule Time* specifies the synchronization of when this should begin. The *Sample Interval* entry indicates how often the sensor should be sampled each time its scheduled to sample and the *Sample Duration* specifies for how long. To average continuously, the *Schedule Interval* should be set equal to the *Sample Duration*.

## Interpolate (Interpolate)

### Inputs

InterIn

### Outputs

InterOut

### Description

The Interpolate block is used to apply a table lookup function to a data stream. This is useful in instances when applying a polynomial function would be too difficult. For values not in the entered table, the output is interpolated from adjoining table entries based on the selected *Method*. The outputted signal can be labeled with new units by clicking the *Units* button.

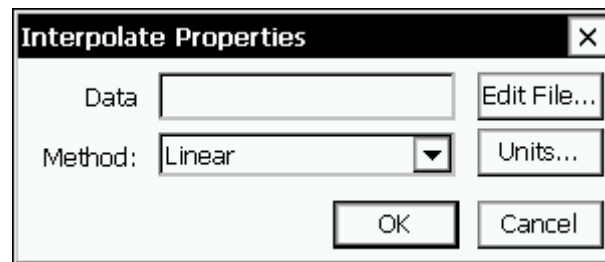

To load, edit or save the file to interpolate from, click the *Edit File...* button. The following window will come up:

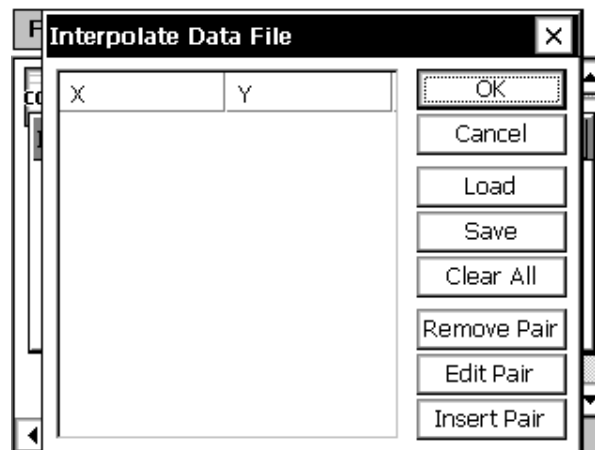

To start creating a new table, use *Insert Pair* to enter pairs of values. The values will automatically sort according to the values in the X column. Any XY pair can be edited or deleted by clicking on that pair and clicking *Edit Pair* or *Remove Pair*. To erase all the entries in the table, click *Clear All*. To save the file or load a previously saved file, click *Load* or *Save*.

For an interpolation table larger than a dozen entries or so, it might be faster to generate it on a PC (with Notepad, for example) and then upload it to the Xpert. Files should be created in comma separate format, such as the below example:

```
10.22, 11.55  
12.481, 20.999  
15.0, 40.01
```

The extension of the file should be changed to .tbl before uploading.



## Georgia Pacific Sampler (GPSmpl)

### Inputs

DigIn

### Outputs

DigOut

### Description

This block samples the input (digital) at a user set interval. When the input transitions from low (0) to high (1), increment sampler count and save the time of the event. Then delay for n seconds (user set) and then force measurements of PH1, T1, PH2 and T2. PH1, PH2, T1 and T2 will be set up using standard blocks by tying a COMS TAG to the blocks that make the measurement and convert the value to the desired units. When the measurements are complete append the following record to \storage card\filename.csv in CSV format:

```
Date, time (edge detected), function, splcnt, ph1, t1, ph2, t2
```

Example:

```
08/27/02, 14:03:10, GPSmpl 1, 125, 5.62, 25.19, 9.73, 28.81
```

Use 2 right digits for ph1, t1, ph2 and t2.

If the file does not exist (because a new card has been inserted), create it. If there is a problem creating, opening, or writing to the file, send a warning message to the report.warning.

If the digital input stays at high (1) for more than 5 minutes, write a warning message to the report.warning.

Init splcnt to 0 when recording is turned on.

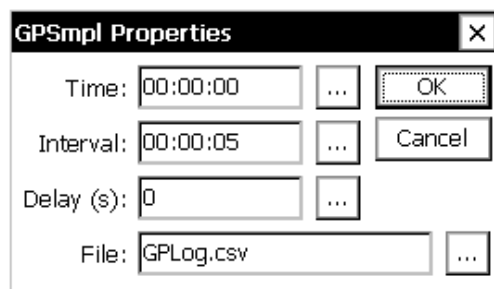



## Measure (Measure)

### Inputs

Input

### Outputs

Output

### Description

Measure blocks are used to create a sampling schedule for sensor blocks. The only time a Measure block (or similar) is not needed after a sensor block is when the sensor block is set to output data based on a specified change on the sensor input (Event mode).

Enter values for the *Time* and the *Interval*. The interval is how often the data from the sensor should be sampled. The time is a synchronization time (not an start time). In the example below, the sensor will be sampled every fifteen minutes, synchronized to the hour. If *Time* had been set to 00:01:00, the sensor would be sampled every fifteen minutes with a one minute offset – if sampling was started at 4:00pm, samples would be taken at 4:16p, 4:31p, 4:46p, etc.

Sensor blocks configured in Event mode do not need to be hooked-up to Measure blocks, but they can be if desired. Doing so will result in data being generated *either* because of a specified change in the sensor input *or* because the next scheduled sampling time has arrived.

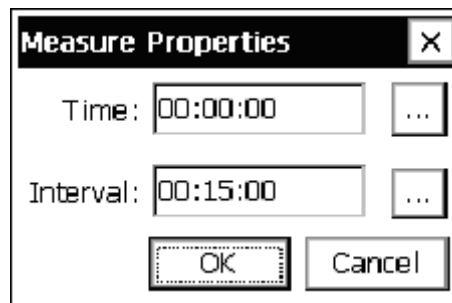

## **Min** **Max** Minimum/Maximum (MinMax)

### Inputs

Input

### Outputs

Min

MinTime (Number of seconds into current day)

Count

Max

MaxTime (Number of seconds into current day)

RMaxVal

### Description

This block outputs its data set at the time and interval defined by the user. The block examines the data received prior to its scheduled interval in order to determine its outputs: the maximum value received, the minimum value received, the time of maximum value, the time of minimum value, and the number of values received. The number from the time outputs is determined by the number of seconds since 00:00:00 of the current day (e.g. a time of 3600, would be 01:00:00).

The block also outputs RMaxVal, which is the value of an optional related item at the time the maximum occurred. This related item is a point in the setup tagged by a ComsTag block. The name of the tag must appear in the “Rel max val” field of the properties dialog. If no tag appears in this field, or if the name is invalid, then RMaxVal is output as 0.

This block is commonly placed after a *Measure* block that is sampling a sensor on a schedule, or directly after a sensor block setup in Event mode. The *Start Time* is an offset time. For example, if the start time below was set to 00:05:00, a measurement would happen at :20:00, :35:00, :50:00, 05:00, etc.

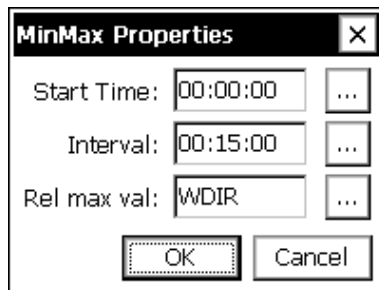

Start Time:	00:00:00	...
Interval:	00:15:00	...
Rel max val:	WDIR	...
OK		Cancel



## Moving Average (MovingAverage)

### Inputs

Input

### Outputs

Average

STD

### Description

This block computes a moving average for the input value with each new sample. This differs from the normal Average block that computes the average only at the end of the scheduled interval. It can be used to compute an average speed over a two minute window with the average being updated every second. The screen that follows shows a 10 minute average with the samples being collected every 30 seconds and output of the average every 30 seconds.

When the block runs, the output data will be flagged as bad until  $\frac{1}{2}$  of the required number of samples have been collected.

The checkbox labeled circular input can be used on wind direction sensors where the output is 0-360 degrees. With this box checked, the average will properly compute the average direction even when the sensor changes through 360 degrees.

The *Schedule* fields are used to control when the software reinitializes its computations. The process of re-initialization eliminates computational errors that would otherwise occur. In the following example, the moving average would reinitialize its computations every 12 hours synchronized to midnight.

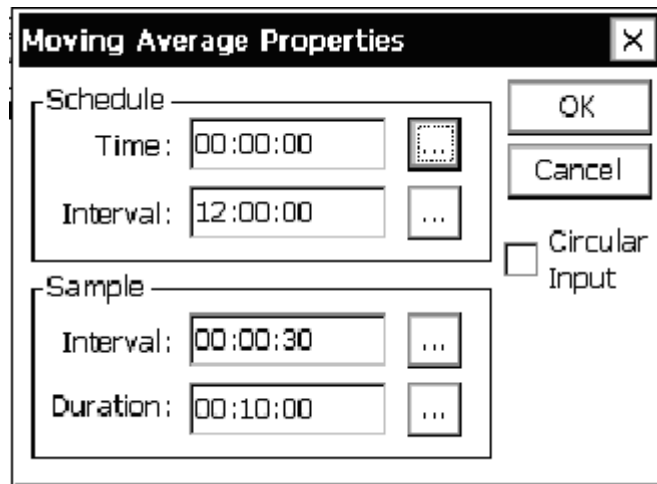



## Polynomial (Poly)

### Inputs

PolyIn

### Outputs

PolyOut

### Description

The Polynomial block is an extremely flexible, general-purpose processing block that can apply a polynomial function in any part of the Setup Diagram data stream. The orders of the desired equation – up to 5<sup>th</sup> order – are entered next to  $k_0$  through  $k_5$ . If the units to be outputted from this block are different from those of the signal that were inputted, those new units can be entered via *Units*.

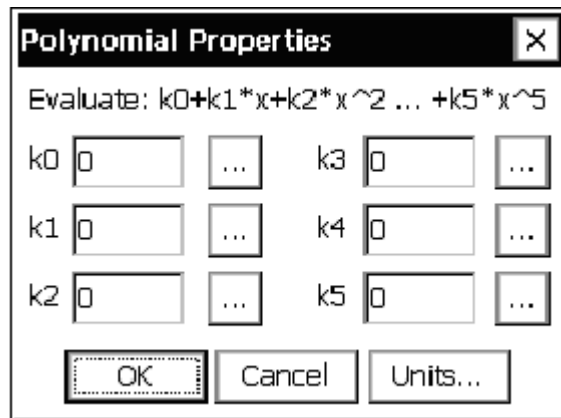

A good use of this block is to generating meaningful values from an unsupported sensor. For example, say there is a humidity sensor that outputs 0.5 to 2.5 volts for 0 to 100% relative humidity (different from the output of any sensors supported by the AT/RH sensor block). The following equation could be determined:

$$y = 50x - 25$$

which would convert the sensor voltage to a relative humidity value ranging from 0 to 100 that could be logged or transmitted.

To implement this in a Polynomial block, the 25 would be entered next to  $k_0$  (for the 0<sup>th</sup> order of the equation) and the 50 entered next to  $k_1$  (for the 1<sup>st</sup> order). Fields  $k_2$  through  $k_5$  would be left at zero since we are only implementing a first order equation. A general purpose VoltMeter or ADC sensor blocks would be used to input the sensor voltage into the system in this case.



## PtCtrl (Point Control)

### Inputs

Point

Enable 1

Enable 2

### Outputs

Move +

Move -

Stop

Status

### Description

The Point Control block is used to control the position of some device using a feedback control loop. The current position of the device is “wired” to the input *Point*. When the position of the device differs more than a user-defined amount, the outputs are set to attempt to bring the position of the device back to the desired point.

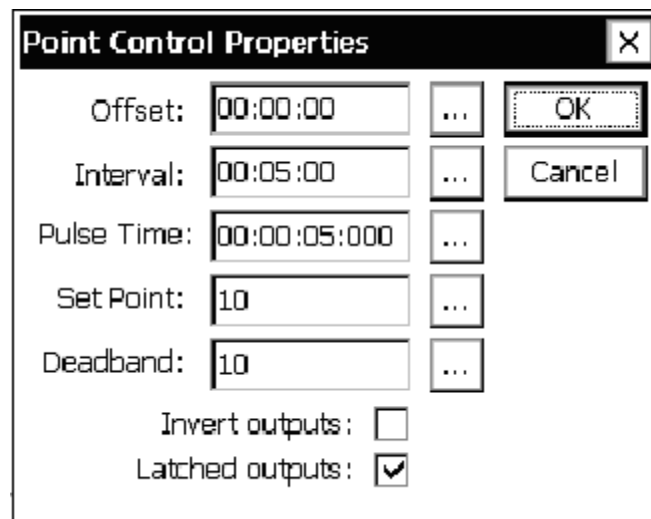

The control loop executes on a schedule set by the user. The *Offset* and *Interval* properties determine when and how often, respectively, the loop executes. Each is specified in seconds relative to a 24-hour clock.

Both enable inputs must be true for the control loop to execute. When *Enable 1* is false, the control loop skips execution and may execute at the next scheduled interval. However, when *Enable 2* is false, the control loop will no longer be scheduled until recording is restarted, regardless of its subsequent states. Also, when *Enable 2* is false, the Status output is set to false (it is set to true at all other times).

The user sets the desired device position by setting the *Set Point* property. The *Deadband* property defines the range of points that are considered to be within tolerance. Specifically, an input *Point* is in within tolerance (i.e. no attempt to reposition is made) when the difference between *Set Point* and input *Point* is less than or equal to *Deadband*.

Moves are accomplished by setting the *Move +*, *Move -*, and *Stop* outputs. These are boolean outputs typically wired to *BinOut* blocks in order to set the state of some hardware control line. When *Latched Outputs* is checked, the selected move line is set high for .25 seconds and then set low. After *Pulse Time* seconds elapses, the *Stop* output is set high for .25 seconds, and then set low.

When *Latched Outputs* is not checked, the selected move line stays high for the duration specified by *Pulse Time* before it is set low. The *Stop* output is not set in this case.

The *Invert Outputs* option is used to invert the sense of the control loop. The “normal” sense occurs when the box is not checked. In this case, *Move +* is selected when the input *Point* is **lower** than *Set Point* by more than *Deadband*. *Move -* is selected when the input *Point* is **higher** than *Set Point* by more than *Deadband*. When the *Invert Outputs* option is checked, *Move +* is selected instead of *Move -*, and vice versa.

## Set Point Control (SetPoint)

### Inputs

Level

### Outputs

Control

### Description

This block compares the values coming in on its input with *Set Point* and outputs a 1 or 0 depending if the condition under *Trigger* is met. The *Deadband* allows hysteresis to be added so that the output will not keep change unless the input moves away from the *Set Point* by a meaningful amount.

This block implements a function similar to that of a household thermostat. For example, say we want to output a value of 1 if the input from an Air Temp sensor block crosses 40°C, except that we want there to be a deadband so that the output won't change from 0 to 1 until the input reaches 41°C and the output won't change from 1 to 0 until the output reaches 39°C. We would set *Set Point* to 40, *Deadband* to 1, and *Trigger* to *Above*.

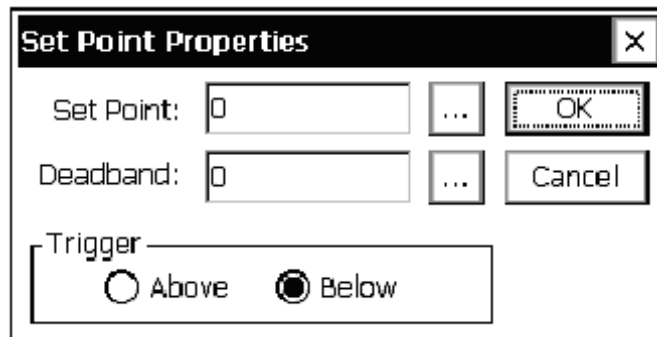

The image shows a dialog box titled "Set Point Properties" with a close button (X) in the top right corner. It contains three input fields: "Set Point:" with a text box containing "0" and a browse button "..."; "Deadband:" with a text box containing "0" and a browse button "..."; and "Trigger:" with two radio buttons, "Above" (unselected) and "Below" (selected). At the bottom right, there are two buttons: "OK" and "Cancel".



## Solar Radiation Accumulator (SRAcc)

### Inputs

SolRad

### Outputs

Accumulation (Accum)

Sunshine (HrsSun)

### Description

This block is designed to do the measurement and processing of data from a solar radiation sensor in order to compute the accumulated value and duration of sunshine. The user set properties of time, interval and sample interval (Smpl Intvl) control the execution of the block. Sample Interval sets how often the block will ask for data from the block connected to it. Typically, this block will be a solar radiation block but it can also be a voltage block or any other input\processing block that is not scheduled. The Time and Interval control when the accumulator is reset back to 0. With an interval of 24:00:00 and a time of 00:00:00, the accumulator would be reset every 24 hours at midnight. Hourly resets or resets at times other than midnight are also possible.

The basic computation of the block is:

$$\text{Accum} = \text{Accum} + \text{sample} * \text{smpI\_intvl}/3600 \quad (\text{smpI\_intvl in seconds})$$

This calculation is done every Smpl Intvl. If the sensor connected to the block has output units of W/m<sup>2</sup>, the output of the block will be WHr/M<sup>2</sup>. So, the block adds the dimension of Hr to the units of sensor it is connected to. The desired units are set by the Units property field.

The Acc Thrshld (Accumulator Threshold) sets the threshold for accumulating solar radiation data. If the input value is less than this threshold, the data will be ignored. Some sensors have a slightly negative or positive output value in low light conditions. The AccThrshld will ignore this data in the calculation.

The Sunshine calculation computes the amount of time that the input is greater than the hour threshold (hr thrshld). The calculation is simply:

If sample > hr\_thrshld then

$$\text{HrAccum} = \text{HrAccum} + \text{smpI\_intvl}/3600 \quad (\text{smpI\_intvl in seconds})$$

Hr Thrshld is typically set to 120 (watts/m<sup>2</sup>) as set by the WMO. If the input is in other units, the threshold value will probably be different from 120.

**SoIRad Accumulator Properties** [X]

Time: 00:00:00 ... [OK]

Interval: 24:00:00 ... [Cancel]

Smpl Intvl: 00:00:05 ...

Acc Thrshld: 0 ...

Hr Thrshld: 120 ...

Units: WH/m2 ▼



## Vector Average (VectAvg)

### Inputs

Speed

### Outputs

Mean Speed Scalar – This is the scalar wind speed, not taking direction into account. The scalar average of 10mph for an hour and 20mph for an hour is 15mph, regardless of changing direction.

Mean Magnitude Unit – This is the vector average of the wind speed using a unit vector. The mean magnitude unit of 5mph at 0° for 1 hour and 100mph at 180° for 1 hours is 0mph (because two unit vector pointing opposite directions cancel when added with vector addition).

Mean Magnitude Wind – This is the vector average of the wind speed which takes direction into account. Here, the average of 10mph at 0° for 1 hour and 20mph at 180° for 1 hour is negative 5mph.

Mean Direction Unit – This is the wind direction (in degrees) not weighted for wind speed. Here, the average of 10mph at 0° with 20mph at 90° is 45°.

Mean Direction Wind – This is the wind direction (in degrees) weighted for wind speed. Here, the average of 10mph at 0° with 100mph at 90° is 84°.

STD Speed Scalar – This is the standard deviation of the scalar wind speed.

STD Direction Unit – This is the standard deviation of the direction unit.

STD Direction Wind – This is the standard deviation of the direction wind.

Min Speed Scalar – This is the minimum of the scalar wind speed.

Max Speed Scalar – This is the maximum of the scalar wind speed.

Max Direction – This is the direction taken at the time the max speed is detected.

Count – This is the number of samples that have been taken.

### Description

The Vector Average block is a special version of the Average block that includes computations to make a vector average. The vector average is important to any sensor that has a circular discontinuity, such as a wind sensor with the crossover from 0 to 359 degrees. This block is, in fact, geared toward wind sensors, but could be used any time performing a vector average is desired. Like the Average block, Vector Average itself requests samples from a sensor and thus does not require a Measure block to be used before it.

Vector Average has the same properties window as the Average block. See the description of Average for an explanation of the different fields:

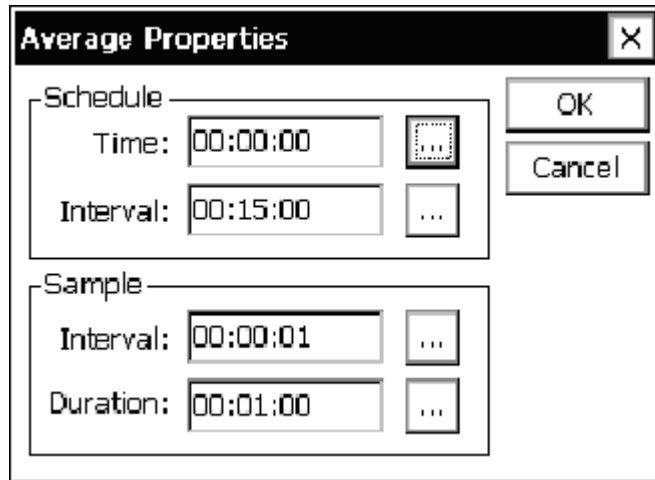

Vector Average has a large number of special outputs corresponding to all the vector computations it makes. To perform most of its computations, the Vector Average block requires signals on both its *Speed* and *Dir (ection)* inputs. These inputs correspond in a general sense to *magnitude* and *angle*, with the angle always specified in degrees.



## XY Function (XYFunct)

### Inputs

X

Y

### Outputs

Z

### Description

The XY Function block is for doing math between two inputs to produce an output value. The two inputs may be from a single block or from two different blocks. To use a constant in an equation (for example, to perform  $x * 4$ ), use the output from a Constant sensor block as one of the inputs. The *Units* button should be used to tell the system what units to label the output values with. If  $x$  and  $y$  inputs have the same units, these units will be retained through to the output.

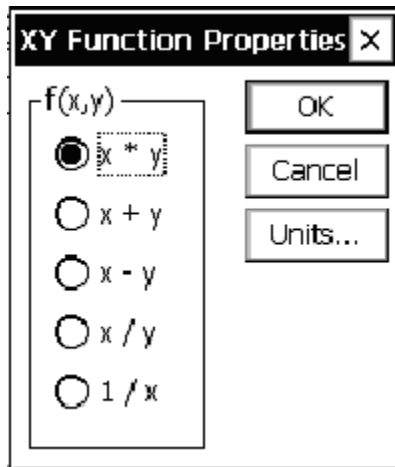

## LOGGING BLOCKS

---

### Log

#### Inputs

Input

#### Outputs

Output

#### Description

This block is used to funnel a data stream into a log file. Generally, one log block is needed for each signal of each sensor that needs to be logged. For example, if temperature and humidity from a AT/RH block needs to be logged, one log block is needed for each. The different log blocks in the system can log to the same log file, different log files, or anything in between.

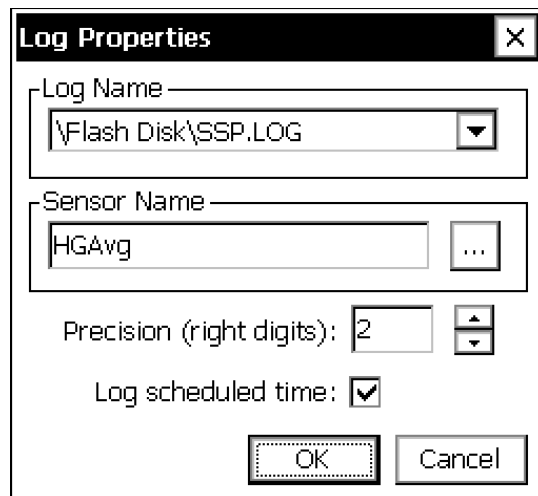

The image shows a dialog box titled "Log Properties" with a close button (X) in the top right corner. It contains the following fields and controls:

- Log Name:** A drop-down menu showing "\Flash Disk\SSP.LOG".
- Sensor Name:** A text box containing "HGAvG" and a button with three dots "...".
- Precision (right digits):** A numeric input field with the value "2" and up/down arrow buttons.
- Log scheduled time:** A checked checkbox.
- Buttons:** "OK" and "Cancel" buttons at the bottom.

From the *Log Name* drop-down menu, select the log file the data is to be stored to. If the log you wish to use does not yet exist, select the “[New Log]” option from the drop-down list and the system will allow you to create a new log.

*Sensor Name* should be set such that it describes the source of the data. This name shows up in the *Sensor* column of the Log tab and is the only way to identify, for example, whether a temperature data point originated from an AT/RH, AirTemp, BP block.

*Precision* defines the number of places to the right of the decimal point that should be stored in the log. Blocks connected to the output of the log block will get a passed-through version of the data stream seen at the block input, except with the *precision* applied.

*Log scheduled time* determines the source of the timestamp that is given to the logged data. When checked, the data is timestamped with the time the data was scheduled to be measured.

When not checked, the time the data is actually finally computed is used. This value may be several seconds after the scheduled time, depending on how long it takes to measure and calculate the final value.

Logging with actual time instead of scheduled time can be useful when logging min and max values produced by the Average or MinMax blocks. When logging these values with “use scheduled time” unchecked, the timestamp of the data is the same as when the sample was taken that produced the min or max value, as opposed to the time the average, min, and max values are finally computed.

# TELEMETRY BLOCKS

---



## Coms Tag

### Inputs

Data

### Outputs

Data

### Description

This block identifies (or “tags”) data to be shown on the Data tab . If the block is connected to an Alarm block, the Data tab will show alarm information for the tagged data point.

The Coms Tag block also “tags” information to be included in SSP communications messages. When another station requests “current data”, “alarm data”, “get tag”, “send tag”, or “eval tag” (these are common SSP requests) the Xpert provides the data from the Coms tags. Therefore, you control the data that is included in the responses to these data requests by attaching a Coms tag to the desired data. NOTE: This “tag” is case-sensitive; therefore, it should always be entered in UPPERCASE letters to avoid confusion.

The Prefix and Suffix phrases are only used in speech/voice modem messages. If you do not see choices for the prefix and suffix, the speech files have not been loaded into your Xpert.

The Right Digits property controls the precision of the tagged data, but only when the check box is checked.

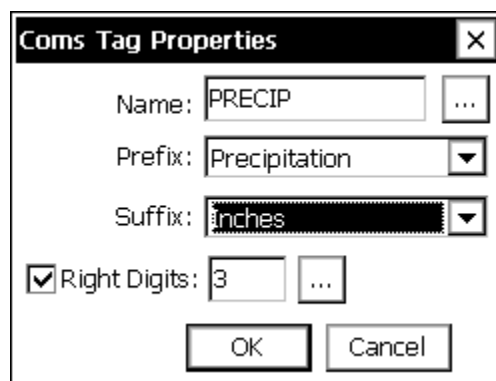

Note: In order to take live measurements of the sensors with which the Coms Tag is inline, there must be no “active” blocks between the Coms Tag and the inline sensor block.

Generally speaking, this means the Coms Tag must be connected after the sensor block, and **before** any Measure, Average, or other active block (an “active” block is one that initiates a measurement, and typically has a darkened border in the graphical setup). If the Coms Tag is connected after the active block, it will not be able to retrieve live data.



## Random Group (RndGroup)

### Inputs

Trigger

### Outputs

Output (pass-through)

### Description

This block defines the alarm conditions for a random transmission group. Its input is typically connected to a sensor that the system is measuring. Each time the sensor is measured and the data is passed to the random group block, the block will check the value for the different type of alarms and trigger an alarm or go out of alarm as determined by the data.

If more than one RndGroup block is used to define a trigger point for the same group, each RndGroup block must have the same DTime, DInter, and Label values. If they differ, the system issues a warning when the setup is saved.

Group lets you define which random group you are defining the alarm properties for. Label defines the string that will be added to the random transmission to identify the group. Typically, label is a single character such as "2" or "3" (e.g., group number). This field can be any length, but only the first 3 characters are used in the transmit message.

A line is placed into the sensors tab for each random group block in the setup. This line is provided as a way to see the current alarm status of the different groups. If a random group line is selected and measured, or if "Measure All" is pressed, then the random group(s) will pull and evaluate their data. This can result in one or both of the following conditions:

If the random group were placed into the setup after a log block, this would send the data pulled into the log, with the time stamp of when it was measured. If it is desired to not have this data go into the log, the random group should be placed before the log block.

This will also evaluate alarm data before the next measurement. This would be useful when a user is at a site and knows that an event occurred that should trigger an alarm transmission, before the next measurement interval.

### Time and Interval

Time and Interval are used to determine what data is transmitted from the data collected by the random parameter blocks. A time of 00:00:00 and interval of 00:15:00 tells the system to consider data with times 00:00:00, 00:15:00 ... 23:45:00 when it is time to format and transmit. This is useful for the situation where the block is connected to an output that is providing data more frequently than it is being transmitted. It also allows the formatter to identify data that is missing when it comes time to transmit it.

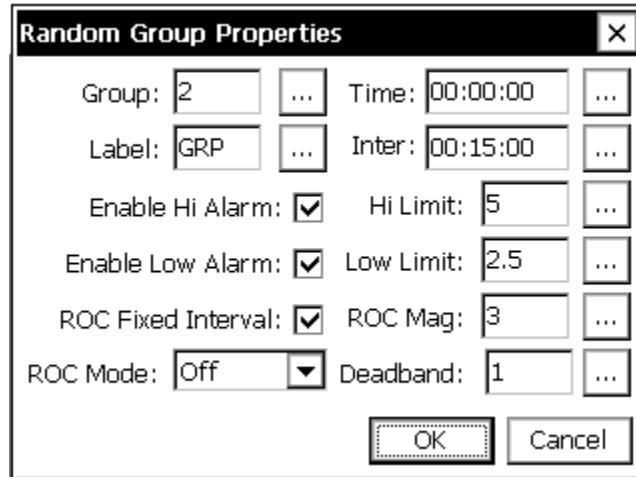

The different alarms are:

Hi Alarm	System goes into alarm if the input value is $> \text{Hi Limit} + \text{deadband}$
	System goes out of alarm if the input value is $< \text{Hi Limit} - \text{deadband}$
Low Alarm	System goes into alarm if the input value is $< \text{Low Limit} - \text{deadband}$
	System goes out of alarm if the input value is $> \text{Low Limit} + \text{deadband}$
ROC Alarm	<ol style="list-style-type: none"> <li>1. When ROC Mode is set to Off, no ROC alarm test occurs.</li> <li>2. When ROC Mode is set to Hi, the system goes into alarm if the change in input value is <math>&gt; \text{ROC Mag} + \text{deadband}</math>. The system goes out of alarm when the change in input value is <math>&lt; \text{ROC Mag} - \text{deadband}</math>.</li> <li>3. When ROC Mode is set to Low, the system goes into alarm if the change in input value is <math>&lt; \text{ROC Mag} - \text{deadband}</math>. The system goes out of alarm when the change in input value is <math>&gt; \text{ROC Mag} + \text{deadband}</math>.</li> <li>4. The change in input value is computed in one of two ways, depending on the state of Fixed Interval. If Fixed Interval is checked, the change in input is calculated as the absolute value of the difference between the current value and the last value. If Fixed Interval is not checked, the change in input is calculated as the absolute value of the difference between the current value and the last value that caused a ROC Alarm to occur.</li> </ol>



## Random Parameter (Random)

### Inputs

Input

### Outputs

Output (pass-through)

### Description

This block allows you to include the data from the input in a random satellite transmission. It is most commonly linked to the output of a log block but can also be linked to the output of a measure or average. The Random Properties dialog is used to enable random transmissions and define the normal and alarm rate for the transmissions. This block lets you assign the sensor to one of the 8 different random groups (groups 2 .. 9). Each group must have a separate trigger sensor defined by the Random Group block. When the trigger sensor goes into alarm (as defined by the Random Group block, above), the Xpert will make a random transmission of all the sensors assigned to that group. At other times, the Xpert will transmit the data for the different groups according to the setup in the Setup tab. A sensor may be in as many groups as desired.

Along with assigning the sensor to groups, this dialog sets the sequence of the sensor (in the transmission) and the number of values to include in the transmission (BIN-NONINT format). The number of values cannot be set in this dialog if the format is set to BIN-INT in the Satlink settings under the Setup tab.

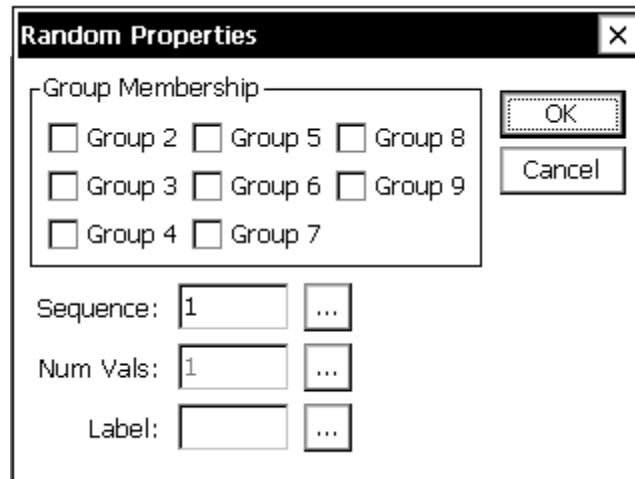



## Self-Timed Parameter (SelfTimed)

### Inputs

Input (the value you want to transmit)

### Outputs

Output (pass-through)

### Description

This block allows you to include the data from the input in a self-timed satellite transmission. It is most commonly linked to the output of a log block but can also be linked to the output of a measure or average. The properties for this Self-Timed block specify what data is included in the transmission and some aids for formatting the data. The main control of the transmission format is in the Setup tab for Satlink, Self-Timed. In this dialog, you can select one of the allowed formats including SHEF, SHEFFIX, BIN-INT, BIN-NONINT, NOS, NIFC, and INSAT. The transmission routines use this selected format and the information in this block to properly format the data.

Self-Timed Properties

Label: AT ...

Data Time: 00:00:00 ...

Data Interval: 00:01:00 ...

Num Values: 8 ...

Sequence: 1 ...

Use calc time:

OK Cancel

### Label

The Label field has multiple uses depending on the transmission format selected. For SHEF and SHEFFIX formats, the value for label is included in the transmission as the sensor ID for the value. The common SHEF IDs are normally simple two letter codes for each sensor such as GH for gauge height, PR for precipitation and so on.

For BIN-INT and BIN-NONINT formats, *Label* is ignored as sensor labels are not included in these format transmissions.

For NOS, the label is used to identify to the formatter the different sensors that must be included in the message. You must put the proper labels for each sensor or the formatter will not be able to locate the sensor to transmit it. The labels are as follows:

Station Datum      **DAT**

Sensor offset	<b>SNS</b>
Primary water level	<b>WL</b>
Aquatrak sigma	<b>SIG</b>
Aquatrak outlier cnt.	<b>OUT</b>
Aquatrak temp. 1	<b>AQT1</b>
Aquatrak temp. 2	<b>AQT2</b>
Wind speed	<b>WS</b>
Wind direction	<b>WD</b>
Wind gust	<b>GST</b>
Air temperature	<b>AT</b>
Water temperature	<b>WT</b>
Barometric pressure	<b>BP</b>
Battery voltage	<b>BAT</b>

For NIFC and NFDRS, the labels are used to identify to the formatter the different sensors that must be included in the message. You must put the proper labels on each sensor or the formatter will not be able to locate the sensor to transmit it. The following table shows what labels are recognized by the NIFC and NFDRS formatter. An “x” means the sensor label must appear in the setup for the formatter to succeed. The items with no “x” are recognized and will be formatted, but are not required.

<u>Sensor</u>	<u>Label</u>	<u>NIFC</u>	<u>NFDRS</u>
Rainfall	PCH	x	x
10-Min Avg Wind Spd	USH	x	x
10-Min Avg Wind Dir	UDH	x	x
Air Temperature	TAH	x	x
Fuel Temperature	MTH	x	
10-Min Avg Rel Hum.	XRH	x	x
Battery Voltage	VBH	x	x
Barometric Pressure	PAH		
Peak Wind Direction	UGX		
Peak Wind Speed	UPH		
Fuel Moisture	MMH		
Solar Radiation	RDH		x

For INSAT, the labels are used to identify the sequence and formatting parameters to use when formatting the message. For each label, an id, offset and scale are associated.

The standard INSAT message encodes the id in an unsigned 4 bit integer, and encodes the data value in an unsigned 10 bit integer. The id is a unique integer from 0 to 19 and is used to determine order (note, however, that since INSAT only uses 4 bits to encode ids, ids appear to start over after 15; this typically requires that decoders consider position, in addition to id).

Encoded values are computed as in the following...

encoded value = ((input data + offset) \* scale + 0.5)

Sensor	Label	Id	Offset	Scale
Avg. Air Temperature	AT	0	50.0	10.0
Max Air Temperature	ATMax	1	50.0	10.0
Data's integer in id 1, fraction to 3 digits in id 2.	R312	1, 2	0.0	1.0
Min Air Temperature	ATMin	2	50.0	10.0
Soil Temperature	ST	3	50.0	10.0
Data's integer in id 3, fraction to 3 digits in id 4.	R334	3, 4	0.0	1.0
Avg. Atmospheric Pressure	AP	4	-600.0	2.0
Relative Humidity	RH	5	0.0	10.0
Data's integer in id 5, fraction to 3 digits in id 6.	R356	5, 6	0.0	1.0
Net Radiation	NR	6	0.0	0.25
Data's integer in id 7, fraction to 3 digits in id 8.	R378	7, 8	0.0	1.0
Wind Speed	WS	8	0.0	10.0
Wind Direction	WD	9	0.0	1.0/.36
Sun Duration	SunD	10	0.0	0.5
Precipitation Duration	Precip D	11	0.0	0.5
Albedometer (skyward)	AlbIn	12	0.0	0.5
Albedometer (downward)	AlbOut	13	0.0	0.5
Global Radiation	Global	14	0.0	1.0
Instantaneous Snow Depth	ISD	15	0.0	100.0
Snow Depth	SD	16	0.0	100.0

Offset is the offset of the sensor's range from 0. Scale is the representable range divided by the range of the sensor.

If the label entered is not in the table above, then it is interpreted as an integer to be used as the Id for the data. An Offset of 0 and a Scale of 1 are assumed when encoding the value in this case. This enables new sensor data to be included in INSAT transmissions without having predefined labels. If a different Offset and/or Scale is required, it can be implemented using a Polynomial block connected in-line prior to the Self-Timed parameter block.

### **Data Time and Interval**

Data Time and Data Interval are used to define which data values coming into the block should be stored for transmission.

For example, a Data Time of 00:00:00 and a Data Interval of 00:15:00 will cause the SelfTimed Parameter block to store any data coming into the block whose timestamp matches those values, i.e., any timestamp in the set 00:00:00, 00:15:00 ... 23:45:00. Similarly, a Data Time of 00:02:59 and Data Interval of 00:06:00 will cause the block to store data whose timestamp falls in the set: 00:02:59, 00:08:59 ... 00:56:59.

Data Time and Data Interval are most useful for when the SelfTimed Parameter block is connected to an output that is providing data more frequently than it is being transmitted. It also allows the formatter to identify data that is missing when it comes time to transmit it.

### **Num Values**

The SHEF, SHEFFIX, BIN-NONINT, and INSAT formats use Num Values to set the number of values of this sensor to include in the transmission.

NOTE: Setting Num Values in the Setup tab first will provide the default value used when adding new SelfTimed blocks to the setup. This can help reduce the number of edits you must make when creating a setup where the Num Values for each SelfTimed block is the same.

The BIN-INT format only uses Num Values entered in the Setup tab. The value in the SelfTimed block cannot be changed. The NOS, NIFC, and NFDRS formats do not use Num Values at all.

When INSAT is the selected format, then when Num Values is greater than 1, previous data is placed into the positions of subsequent ids. For example, when sensor id 2 has a Num Values of 3, the most recent value is transmitted as id 2, the next most recent value is transmitted as id 3, and the next most recent value is transmitted as id 4. Note how this precludes having sensor ids 3 and 4 defined in the setup. If a multiple-position id (e.g., R356) is encountered with Num Values greater than 1, the values are repeated only within the first frame of the message, and only so many times as to ensure complete entries (an orphaned integer entry will not occur).

### **Sequence**

Sequence is used by the SHEF, SHEFFIX, BIN-INT, and BIN-NONINT formats to define the order of the sensors in the message. It is not used by the NOS, NIFC, NFDRS, and INSAT formats as these have a fixed sequence.

## **Use Calc Time**

The “Use Calc Time” checkbox is used to specify that the input data’s actual time of calculation should be used for all formatting considerations, and not the data’s scheduled time. This option is available only when SHEF or SHEFFIX is the current format.

Using the calculated time is useful when the input data is a min or max point from the min-max block. When this is the case, the data point will be collected regardless of the offset and interval property values, and will be formatted with its own label, offset, and interval fields, despite the value of num values. This allows the timestamp of the incoming data to be determined at runtime, and for it to be formatted with an accurate offset field.

## OUTPUT BLOCKS

---



### Binary Out (BinOut)

#### Inputs

BinIn

#### Outputs

BinOut

#### Description

This block is used to output to one channel (output) of a Digital I/O Module. Select the module number, the channel number, and whether or not the output should be inverted. For more on how Digital I/O Module channels can be used as outputs, see the Appendix C: I/O Modules.

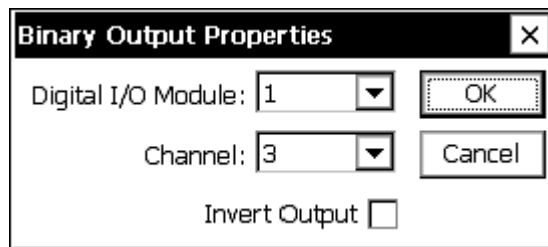



## Pulse Out (PulseOut)

### Inputs

In

### Outputs

Out

### Description

This block is used to generate a pulse on a digital output for a short duration defined by Pulse time. A new pulse will be output each time the block is executed with an input value that is non-zero. The normal state of the digital output pulse will be OFF, ON, OFF. If invert is selected, the pulse will be ON, OFF, ON. Where ON = input grounded, OFF = Pull-up to internal +V (depends on channel, see appendix for detailed specs). Note: any pulse in progress when recording is stopped is terminated, and so may end prematurely.

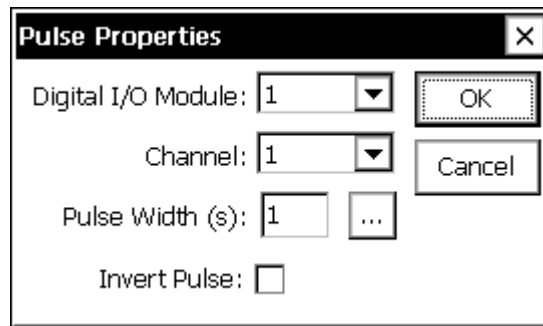

Use the Digital I/O Module and Channel properties to set the module and channel. Set the width of the desired pulse in the Pulse Width property, fractional seconds are accepted (e.g. 0.1).

**NOTE:** If using a digital io module with version 2.03 or earlier, DO NOT use pulses of 1 second or less (e.g. use 1.1 or more). Starting with 2.5, more accurate pulses are used via the modules built-in pulse function. In version 2.03 and earlier, this does not work as it corrupts other channels.



## Send Tag

### Inputs

Data

### Outputs

<none>

### Description

This block will send the current data in the block to another station using Sutron Standard Protocol (SSP) communications. The properties for the block specify the port to use for the communications and the path or station name. The port can only be specified if you have first used the Setup tab COMS control and defined some communications ports. The path can be a simple station name or a station with full path information included (such as *\patha\pathb\stationx*).

The Tag property must match the name specified in a COMS Tag in the named station. For example, Station 1 is measuring water level and wants to send the water level to Station 2. Add a SENDTAG after the measure of the water level in Station 1. Set the Name to WL and also set the port and path for the link between the two stations. In Station 2, add a COMS Tag and set the name property to WL. Now whenever SENDTAG runs, the code will send the water level to the COMS tag block in Station 2.

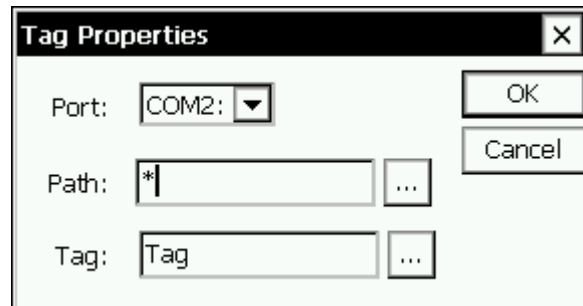

## MISCELLANEOUS BLOCKS

---



### Display (Display)

#### Inputs

Input

#### Outputs

Output

#### Description

The Display block is used select data that gets displayed on the 9210's I2C Display. The data displayed is the last measured value for the block connected to the display block. The data is displayed at the requested precision (right digits) with the selected Label.

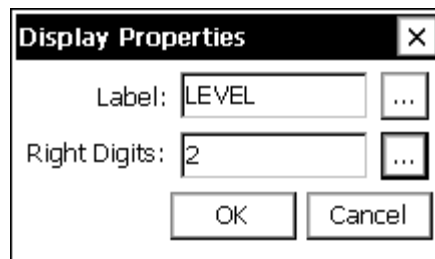



## Field Variable (FieldVar)

### Inputs

Input

### Outputs

Output (pass-through)

### Description

The FieldVar block is used to place shortcuts to setup block properties on the View Data tab, outside the Setup screen. Reasons for wanting to do this might be for simple convenience, or to give a user that does not have access to the Setup screen the ability to change some setup block properties.

The FieldVar block has one input and one output. Connect the output of the target block to the FieldVar input. Viewing the properties of the FieldVar block will then reveal a list of the all the changeable properties of the target block. Below is an example of the FieldVar properties screen when hooked-up to a Measure block.

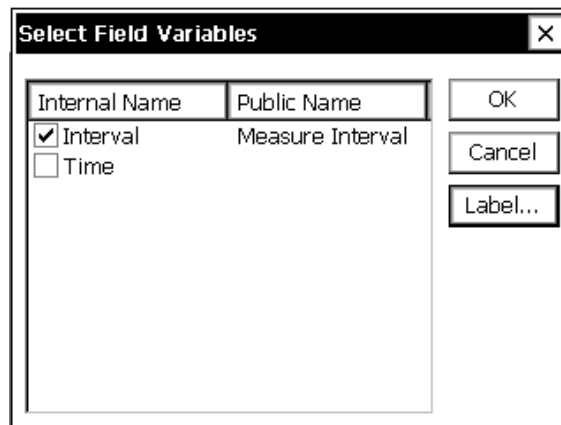

To create a shortcut to a property to be placed on the View Data tab, put a check next to that property.

Checked properties must have unique *Public Names*. This name defaults to the Internal Name when OK is pressed. The *Public Name* for a property is changed by clicking the property name and then clicking *Label...*

Below is an example of how the View Data tab looks when a Measure block has been connected to a FieldVar block with Interval checked and assigned the public name of “Measure Interval”.





# Appendix B: Updating the Firmware

## UPDATING THE FIRMWARE

---

From time to time, Sutron will make available new versions of firmware, in order to introduce new features and fix the occasional bug. These updates are typically made available as downloads on the sutron website ([www.sutron.com/downloads/software.htm](http://www.sutron.com/downloads/software.htm)).

If your system is performing up to your expectations, you may not want to update your firmware, since there is always some risk of introducing a new problem into the system. If you are unsure whether to update your system, and would like to know more about the contents of a particular firmware update (what it adds and what it fixes), contact Sutron Customer Service and request the engineering bulletin for the update.

### Using XTerm Upgrade

Upgrading using the XTerm Upgrade button is the simplest way to update the Xpert. Pressing the Upgrade button brings up an Open dialog that allows you to select the name of an upgrade file. When Sutron has new versions of the software, the new versions are distributed along with an upgrade file to make the upgrade process as simple as possible. The upgrade file specifies what part of the Xpert to upgrade, including the loader, kernel, extension, and/or application.

The steps to perform this kind of upgrade, are as follows:

1. Download the upgrade from [www.sutron.com/downloads/software.htm](http://www.sutron.com/downloads/software.htm). The upgrade typically comes in a zipped archive, and typically has a name similar to "Xpert vX.X.X.X.zip". Once downloaded, unzip the archive onto your PC.
2. Connect your PC to the Xpert using a direct serial cable connection to COM1 (if you are NOT upgrading loader, kernel, or extension, another command-line-enabled com port may be used).
3. Start XTerm.exe on your PC.
4. Press the "Upgrade" button on the right side of the XTerm window.
5. Select the file "Xpert vX.X.X.X.upg" (where X's are replaced by firmware version) in the Open dialog. The upgrade will proceed and finish automatically.
6. The contents of the upgrade file specify what part of the Xpert to upgrade. The parts upgraded may include the loader, kernel, application files, speech files, and custom application files (SLLs). When Sutron releases a new version of software for the Xpert, the new version is distributed along with a new upgrade file.
7. After selecting the upgrade file, XTerm uses the upgrade file as a script to guide the upgrade process. Dialogs are displayed showing the progress of the upgrade. Occasionally, the upgrade script may cause the Xpert to reboot in order to make changes.

### Customizing an XTerm Upgrade

Users can make their own upgrade files or edit the ones provided by Sutron depending on individual needs. The upgrade file is a simple ASCII file such that it can be edited with notepad.exe.

An example upgrade file is shown below. To save space, the many steps required to delete all potential custom slls, and to send all possible speech files, have been left out.

```

; Sample XTerm one touch upgrade file for upgrading the Xpert
;
; Set the default source directory for the kernel upgrade
; (eliminate if upg in same directory as files):
p "c:\Xpert\upgrade\"
;
; Upgrade the loader, kernel and extension
l "xpert.lod" "-" " loader (step 1/5)"
k "xpert.ker" "-" " kernel (step 2/5)"
e "xpert.ext" "-" " extension (step 3/5)"
;
; Reboot the Xpert, bypassing autoexec.bat
b "bypass" "-" " (step 4/5)"
;
; Remove old programs
d "Xpert.exe"
d "Remote.exe"
d "Engine.dll"
d "Logger.dll"
d "LogMgr.dll"
d "LZO.dll"
d "SDI.dll"
d "Utils.dll"
d "Basic.sll"
d "Coms.sll"
d "DefLib.sll"
d "Ezsetup.sll"
d "Satlink.sll"
;
; Send over any custom slls needed here by removing the semicolon
; to send the file, or add your own custom sll to this list.
p "sll-extra\"
;s "Aanderaa.sll"
;s "Airgap.sll"
;
s "autoexec.bat";
; Reboot, we should be all done
b "-" "-" " (step 5/5)"

```

The commands used in the script are:

- p set default source directory
- d delete the specified file
- s send the specified file
- b reboot

Format of commands:

CMD-LETTER "SOURCE" "DESTINATION" "NOTE"

CMD-LETTER is a single character specifying the command to perform

SOURCE is a quoted string specifying a file to operate on

DESTINATION is a quoted string specifying a file to operate on

NOTE is a message that will be displayed in the progress bar

Unused parameters at the end of a command may be omitted. Blank quoted strings are not allowed. Use "-" if you wish to skip a parameter, but specify a later one. If the default source directory is not provided, the directory where the upg file is located is used.

## Manual Component Upgrade

Individual firmware components can be upgraded using methods other than those listed above. This section describes those methods.

Be careful upgrading individual components of Xpert firmware because of incompatibilities across different versions. The set of files contained in a single download archive from the website are all compatible. As a general rule, don't mix with other versions, unless specifically told to do so by Sutron customer service.

### Upgrade the Boot Loader

To update the loader, follow these steps:

1. Start hyperterm or other communications program on a PC. Set the baud rate to 115,200. Connect the COM1 serial port to the Xpert
2. Power up the Xpert. Press ESC in response to the message "Press ESC to upgrade system".
3. The system will prompt to update the loader, kernel etc. Press **L** to update the loader.
4. Use the menus on your communications program to select 'Send File', select y-modem protocol, and specify the name of the loader file (????????.lod).
5. Watch closely to make sure the transfer is successful. When the transfer is complete, the Xpert will prompt: Press Y to burn the loader into memory. If the transfer was successful, press Y and it will be burned into memory. **If it was not successful, press N, restart the unit and try again. Note: if you burn in a loader what was not successfully transferred, the loader may no longer work and your unit will need to be returned to Sutron for service.**
6. After the loader is burned into memory, turn off the Xpert.

### Initialize the Flash File System

To initialize the flash file system, follow these steps. **Warning: this is the equivalent of a format on a hard disk. All the information in the flash file system will be lost. This step is only needed when the flash disk appears corrupted.**

1. Power up the Xpert. Press ESC in response to the message "Press ESC to upgrade system".
2. The system will prompt to update the loader, kernel etc. Press **F** to update the flash file system.
3. Use the menus on your communications program to select send file, select y-modem protocol, and specify the name of the flash initialization file (Finit)

4. When the transfer first starts, the Xpert will take about 50 seconds to erase memory during which time, the communications program may display messages about communications errors. After 50 seconds the transfer will begin. Since the Finit file is 0 bytes long, the transfer will complete immediately after the memory is erased.
5. When the transfer is complete, turn off the Xpert.

## Update the Kernel and Extension

To update the Kernel and Extension (the operating system) follow these steps:

1. Power up the Xpert. Press ESC in response to the message "Press ESC to upgrade system".
2. The system will prompt to update the loader, kernel etc. Press **K** to update the kernel.
3. Use the menus on your communications program to select 'Send File', select y-modem protocol, and specify the name of the kernel file (?????.ker)
4. When the transfer first starts, the Xpert will take about 50 seconds to erase memory during which time, the communications program may display messages about communications errors. After 50 seconds the transfer will begin. A transfer of 1.8MB will take about 5 minutes.
5. When the transfer is complete, turn off the Xpert.
6. Power up the Xpert. Press ESC in response to the message "Press ESC to upgrade system".
7. The system will prompt to update the loader, kernel etc. Press **E** to update the extension.
8. Use the menus on your communications program to select 'Send File', select y-modem protocol, and specify the name of the extension file (?????.ext)
9. When the transfer first starts, the Xpert will take about 50 seconds to erase memory during which time, the communications program may display messages about communications errors. After 50 seconds the transfer will begin. A transfer of 500K will take about 60 seconds.
10. When the transfer is complete, turn off the Xpert.

## Update the Application

To update the application program (Xpert.exe) and its associated DLL's / SLL's follow these steps:

1. BACKUP ALL SETUPS (.ssf files) LOGS (.log files) and AUTOEXEC.BAT files before proceeding. Do this using Xterm and file transfer the files to your PC.
2. Copy the new Xpert application files to a separate empty directory on your PC. Also copy subdirectories that have optional sll's, basic English voice files and optional English voice files. **NOTE:** The Sutron web site download page has a single file called xpert\_app.exe, this is a self-extracting zip file that will setup c:\xpert and all needed subdirectories.
3. Connect a PC running a terminal program (such as HyperTerminal) with the settings of 115200 baud and 8,N,1.
4. Type "reboot", or remove and re-apply power, to restart the unit. NOTE: Do not type quotes on any of these steps. Type only what is inside, then hit the ENTER key!
5. When you see the message "Press Ctrl-C to skip execution of Autoexec.bat", press the CTRL and C buttons. You should then see "Bypassing \flash disk\Autoexec.bat, running Remote." in the next few lines, if not, simply repeat this step until you do.

6. FOR UNITS PRIOR TO VERSION 1.3.0.12 ONLY, you will need to configure the speech directories for voice modem use. Type "dir", if you see an [English] and/or a [Spanish] subdirectory, you will need to delete the files from these using XTerm. Once the files are deleted from the subdirectories, the subdirectories can be deleted by typing "RD English" and "RD Spanish". Then you will need to add new subdirectories by typing "MD Speech", "CD Speech", "MD English". If adding additional languages, type the "MD" and language name for all languages being added. If you do not see an [English] and/or a [Spanish] subdirectory, simply add the new subdirectories.
7. Close the terminal program and run XTerm.
8. Press the XTerm files button on the right of the XTerm display. You will see a list of Xpert files on the right and a list of PC files on the left.
9. Make sure the Xpert (the right side of XTerm) is displaying the *flash disk* directory.
10. Change the directory on the left side of the Xpert screen to the directory where you have the updated programs. You can do this by typing in the location (I.E. c:\xpertapp) and pressing tab, or by double clicking through the list.
11. Press Select all to select all of the programs. Use the CTRL button and click to unselect any files you do not want to overwrite (i.e. autoexec.bat, system.log etc.)
12. Press the ==> button to transfer the files to the XTerm flash disk. Press OK to start the transfer and wait for the transfer to complete.
13. OPTIONAL: Select additional sll's needed from sll-extra and press ==> to transfer them. Currently only NIFC and NOS applications require additional sll's.
14. Go into English subdirectory on BOTH the PC and XPERT sides.
15. Press the ==> button to transfer the files to the XTerm flash disk. Press OK to start the transfer and wait for the transfer to complete. On PC side, go up one directory, and then go down into \English-extra subdirectory. From here select additional voice files needed for your application, then Press the ==> button to transfer the additional files into the English subdirectory on XPERT.
16. DO NOT make an English-extra subfolder on the Xpert; all English files will be in the English subdirectory.
17. FUTURE / OPTIONAL: Repeat steps 14-16 for other language files.
18. OPTIONAL: Modify autoexec.bat file, see section on autoexec.bat and remote.exe.
19. Remove and reapply power to the unit. Verify that system is running.



# **Appendix C: I/O Modules**

## ANALOG I/O MODULE – 8080-0003

---

The Analog I/O Module (ADC) has six analog I/O lines, an output that can be switched to ground and switched and unswitched 12 volt outputs. The analog lines are capable of being inputs and outputs simultaneously giving the user tremendous flexibility in setup. As an example, the simple resistance measurement is made by exciting the input the resistor is connected to and measuring the current and voltage on that input line just as would be done using a conventional multimeter.

### Features

- Six inputs configurable as 6 single ended channels or 3 differential inputs or a combination of single ended and differential inputs. All channels feature self-excitation and built-in voltage, current and resistance sensing.
- Input gain settings 1, 16
- Up to 6 4-20ma sensor interface
- 22 bit resolution
- Continuous self-calibration
- – Vout (excitation) return for maximum common mode rejection of bridge sensors
- One switched battery sensor power output
- Industrial temperature range operation –40 to +60°C
- Multiple sampling rates and digital filtering
- Ability to make resistance measurements without additional external resistors.
- Viewing the card from the front, the plug assignments are as follows:

1	2	3	4	5	6	7	8	9	10	11	12	13	14	15	16	17	18
G	1 1+	G	2 1-	G	3 3+	G	4 3-	G	5 5+	6 5-	Au x1	- EX	N C	G	G	Bat	SwB at

- G = Ground
- Bat = 12 volts out
- SwBat = switched 12 volts out
- Aux1 = switch to ground
- -EX = negated excitation voltage
- NC = No Connections
- Differential channel pairs are 1-2, 3-4, 5-6. The higher voltage line goes to the odd line.

## Specifications

Parameter	Min	Typ	Max	Units
<b>Input</b>				
Range	-5		5	Volts
Resolution <sup>1</sup>	22			Bits
Absolute Error 25°C -40°C to +60°C			0.0015 0.03	%FS <sup>6</sup> %FS <sup>6</sup>
Ratiometric Error <sup>2</sup>			0.0015	%FS <sup>6</sup>
CMRR		70		dB
60Hz Rejection	100			dB
Rin Single Ended Differential Common Mode	20 20 20			Meg Ω Meg Ω Meg Ω
Sampling Rates	10		2000	Hz
<b>Excitation</b>				
Range	-5.0		+5.0	
Output Current			10	mA
Output Impedence		110		Ω
Absolute Error 25°C -40°C to +60°C			0.0015 0.03	%FS %FS
Ratiometric Error <sup>3</sup>			0.005	%FS
Frequency	0		10	Hz
<b>Sensor Power</b> (VBAT from Data Logger)				
Voltage	9		14	Volts
Current			100	mA
<b>Protection</b>				
Static Discharge <sup>4</sup>			2000	Volts
Conducted <sup>5</sup>			400	Volts

<sup>1</sup> Sampling rate = 10 Hz, Gain = 1.

<sup>2</sup> Error which will not cancel when two measurements are expressed as a ratio.

<sup>3</sup> Excitation outputs are connected internally to A/D converter. This value is the accuracy of this measurement. Available voltages are the integer values between -5 and +5 V.

<sup>4</sup> Human body model.

<sup>5</sup> One microsecond rise, one millisecond fall.

<sup>6</sup> Channel 1, Differential over -4.8 to 4.8 Vin

## Operational States

The ADC has two operational states - *running* and *stopped* - which are controlled by commands to the device.

### Running

In this state, the input lines are sampled and processed. This state consumes more power than the stopped state, so the ADC card should be left running only if necessary. The digital output line may be pulsed using the pulse command. The ADC executes a reset sequence when it receives the run command. When the reset is complete, a message is sent to the host.

### Stopped

In this state, the device is idle. It will accept commands, and the output Aux1 will reflect the last command that set this output to either open (1) or switched to ground (0). The input lines are not sampled. Pulse commands will be ignored in this state.

## Inputs/Outputs

### Inputs

The ADC has six single ended analog inputs which may be paired to form differential inputs.

### Outputs

The ADC provides:

- One 12-volt output (Bat)
- One switched 12-volt output (SwBat)
- One output that can be switched to ground (Aux1)
- Six excitation channels (analog outputs) that can be programmed from  $-5V$  to  $+5V$ , and,
- One output  $-Ex$  which is always the negative of the current excitation voltage value.

The excitation channels are shared with the input lines. Only one excitation channel can be active at a time. The negative of this voltage provided on  $-Ex$  can be useful in balanced bridge applications to minimize common mode voltage.

The output Aux1 provides a switched path to ground that, when closed, grounds through a 100-Ohm resistor. The state of this output may be pulsed using the pulse command. It may be pulsed open or closed. If the output is already in the state that the pulse command requests, nothing will happen. The ADC device must be in the running state to pulse Aux1.

The board must be in the running state to switch the SwBat on. This will turn off if the device goes to the off state.

## Analog Measurements

The ADC can measure voltages on its terminals and across internal sense elements. Sense element voltages allow currents to be calculated by a host processor. The ADC can also take paired terminal voltage and sense element voltage measurements that can be used to compute resistance values.

The ADC has a built-in low pass filter for noise rejection that is programmable for a 10 to 1900 Hz cutoff. The filter has notches at multiples of the cutoff frequency.

The ADC will automatically take up to 255 measurements spaced from .001 sec to 65.535 sec apart, sending the results to the host as each measurement is completed. The ADC also provides for up to 65.535 seconds of sensor warm-up delay before making its first measurement. If the specified warm-up delay is less than 3 sampling periods, the delay before the first reading is taken will be 3 sampling periods. This should be taken into account when computing the warm-up delay.

Note that while the sampling frequency is programmable, the *maximum* sampling frequency is equal to the cutoff frequency you have programmed into the filter. The frequency at which the ADC samples its input and that at which it captures and sends data to the host are not the same. The input is sampled at 1/FilterNotch (frequency cutoff of ADC input filter). The capture and send frequency is specified by the host in the form of a sampling period which is specified in milliseconds. If the filter cutoff frequency is lower than the sampling period frequency, then data is sampled and transmitted at the filter cutoff frequency rate. Otherwise, the data will be sampled and transmitted at the sampling period frequency.

## **Accuracy**

The ADC will self calibrate to its internal reference whenever the calibrate command is received. The reference, while very stable, is accurate to  $\pm 1\text{mV}$ . This error is measured during factory test and is written into the ADC ROM. A read Vref error command can be used to read this error and use it to obtain 0.0015% error (at 25°C). Another set of coefficients can be read to calibrate readings when the ADC gain is set to 16.

## Example Configurations Using the Analog I/O Module

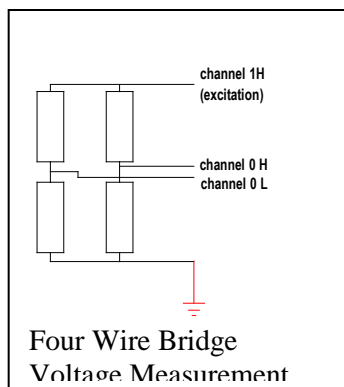
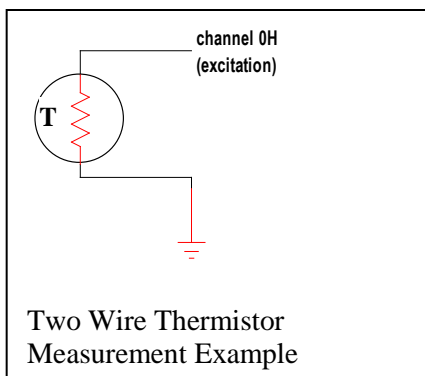
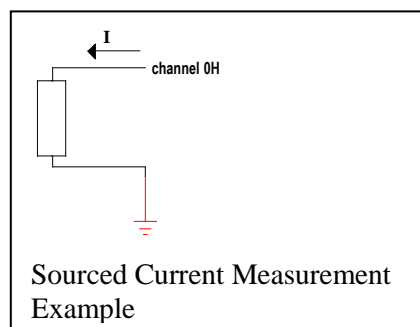
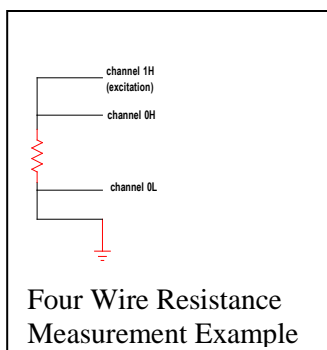
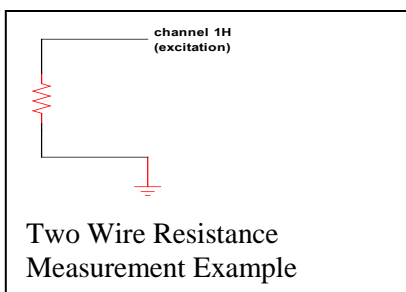
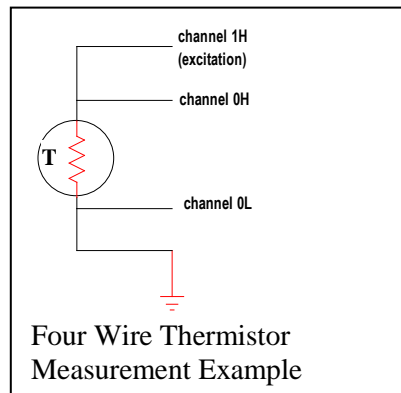
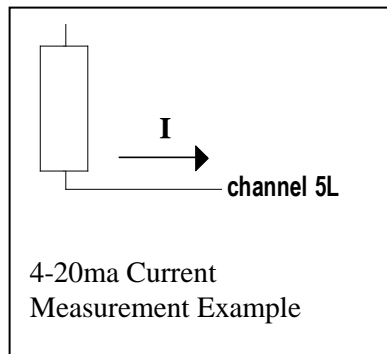
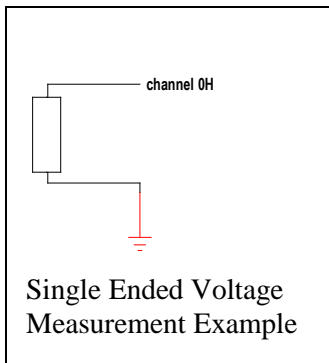

## DIGITAL I/O MODULE

This section describes the control and operation of the Xpert Digital I/O module. The Digital I/O module has eight digital input lines, six of which may be re-programmed as outputs. The two dedicated input lines can be programmed for normal sensitivity for sensing 0 to 5 volt digital signals, or high sensitivity for sensing low level signals such as those from an R.M. Young wind speed sensor.

### Features

- Eight digital I/O lines, CMOS level inputs
- Six bi-directional, two input only
- Reconfigurable I/O
- Up to eight counters/frequency inputs with programmable alarm
- count leading edge, trailing edge or both edges of input pulse.
- Up to four quadrature shaft encoder inputs (requires two inputs per sensor) with programmable alarm
- Two switchable threshold inputs compatible with R M Young wind sensor.
- Switched sensor power
- Industrial temperature range operation  $-40$  to  $+60^{\circ}\text{C}$

Parameter	Min	Typ	Max	Units
<b>Inputs</b>				
Inputs				
Sampling Interval	.5		2000	Hz
Switchable threshold	.02		2.5	Volts
integration time	.1		10	seconds
period measurement	.1		6.5	seconds
<b>Output(open drain MOS switches)</b>				
High <sup>1</sup>			8	Volts
Low <sup>1</sup>	0			Volts
Resistance	60		100	$\Omega$
<b>Sensor Power</b>				
Voltage	9		14	Volts
Current			100	mA
<b>Protection</b>				
Static discharge <sup>2</sup>			2000	Volts
Lightning, Conducted <sup>3</sup>			400	Volts

<sup>1</sup>CMOS levels.

<sup>2</sup>Human body model.

<sup>3</sup>1 microsecond rise, 1 millisecond fall.

Viewing the card from the front, the plug assignments are as shown below. The I/O lines are numbered 1-8 (LSB is 1).

1	2	3	4	5	6	7	8	9	10	11	12	13	14	15	16	17	18
G	1 *	G	2	G	3	G	4	G	5	G	6	G	7 #	G	8 *#	G	SW BA T

G = Ground

\* = Input Only

# = Switchable sensitivity

## Inputs

When programmed as an input, each line can act as a digitally filtered counter clock or a shaft encoder input. Shaft encoders require two input lines, hence, users can have up to four shaft encoders, eight counters, or a combination of the two. Alarms can be programmed to send a message to the logger if a counter exceeds a limit or a shaft encoder moves above or below preset thresholds. When a run command is received, sampling of the inputs starts at the user specified sample rate. Since the counters and shaft encoders react to an input change, an initial state must be assumed when the run command is received. The Digital I/O reads the inputs when it gets a run command and uses these values for the initial state of the filter.

## Digital filters

The inputs can be low pass filtered before being applied to counters. Shaft encoders are not filtered. The digital filters are up-down counters that count between 0 and a user defined threshold value. Each input line's filter can have a different threshold value. The input to a filter is one of the eight input lines, the output feeds a 32-bit counter. The filter counts up at each sample interval when its input is a one and down when its input is a zero. The counter will not count up if it is at its upper threshold, and it won't count down when its count is zero. The output of the of the filter only changes state when the counter reaches zero or its upper threshold. Thus, if the output state of the filter is a one, it will stay a one until the counter reaches zero. It will then remain zero until the counter counts up to its upper threshold. Valid digital filter time constants are 1 to 255.

## Counters

Up to eight 32-bit counters can be programmed to count on both edges or just the positive-going edge of their respective inputs. Since the input to the counter can be inverted under program control, the counter can also be made to count on the negative going edge by inverting its input. The counter alarm message can be set to be sent after 1 to 255 counts.

## **Frequency**

The time is logged for each counter every time it counts. This time is reported for each counter when the counters are read. Frequency can be measured by reading the counters twice and computing the difference in time and counts.

In cases where counts are infrequent, it is possible that the counter will not have counted when it is read for the first time. If this value is used in a frequency computation, an invalid frequency computation will result. There are two ways to prevent this. The counter's alarm can be set to one. When the alarm is received, it will be an indication that the count and time are valid. Alternatively, the user can monitor the count until it changes to therefore know that count and time are valid.

## **Shaft encoders**

Up to four quadrature shaft encoders may be set up. The input lines must come from adjacent inputs starting with an odd numbered one (e.g.: 1,2; 3,4; 5,6; 7,8). Each shaft encoder has a 32-bit counter associated with it. It counts up for one direction of rotation and down for the other. The direction of rotation that increments the counter can be changed under program control by inverting one of its inputs. Each encoder also has two alarm thresholds, one for each direction of rotation. The thresholds are between 1 and 255 counts.

## **Outputs**

Each of the six lines with output capability can be turned on or off under control of the logger. Any output can be pulsed using the pulse output command.

# Appendix D: Specifications

## Basic Unit with Display – 8080-0000-1

Processor	AMD SC400 @33/66 MHz
Memory	6MB Flash (2MB flash file system for log) 8MB DRAM PCMCIA Type II slot
Power	9.5 to 16 VDC with reverse protection 150 ma active 2ma standby 200uamp suspend
Clock	Real-time clock with battery backup 0.01% accuracy -20 to +60C
Display	320x240 transfective LCD Touchscreen overlay for LCD -10C to +60C operation
I/O	I2C bus, 100Kbps, 5 wire, 10ft max SDI-12 Rev 1.3 RS232 to 115Kbps Internal speaker 3 RS232
Packaging	6x8x2 aluminum case weight 2lbs
Compatibility	Y-Modem SSP Satlink
Environmental	-40 to +60C operation except display

## Basic Unit without Display – 8080-0001-1

The specs for the basic unit without display is the same as the unit with display except there is no display or touchscreen.

## I<sup>2</sup>C Modules

Packaging	4.25 x 3.5 x ¾ inches 0.5lbs stacking interconnect
Connectors	I2C bus: DB-9 User I/O: Phoenix MiniCombicon 3.81 mm x 18 max, removable header

## RS232 Modules

### Speech Modem

A telephone modem expands the system by allowing remote connections to other nodes including a central system. The module includes a modem capable of operation at speeds up to 33.6 kbps. This makes it possible for the remote connection to perform all functions as though the module were local to the system such as retrieve data from the memory module, live data from any module, troubleshoot, diagnose, configure, reconfigure nodes etc. Sutron

8080-0005-1 modem includes V.42 and MNP 2-4 and 10 error correction modes as well as V.42bis and MNP-5 data compression. The modem is UL, CSA, FCC and CTR21 approved.

The Sutron 8080-0005-1 modem has capabilities to support speech. The modem accepts DTMF tones to control the speech and interact with a caller. The user can record custom phrases and words to augment the standard vocabulary using standard PC hardware and software.

### **LOS Radio**

The recorder has a serial port for connecting LOS Radio modems. The port is be compatible with third party radio modems such as those manufactured by MDS. Using a radio modem provides one or two way communications between nodes or a central station. The modem makes it possible for the remote connection to perform all functions as though the module were local to the system. Two nodes may use radio communications over a short distance to eliminate expensive wiring. At other times, radio communications will be used between the nodes and a central station. The radio modems must be compatible with repeaters in cases where there is not a clear line-of-sight between two nodes.

### **Satlink Transmitter**

The recorder has a serial port for connecting a Sutron Satlink transmitter. The recorder will set up and operate the satellite radio through the serial port. The setup includes specifying of the transmit mode, ID, time, interval, setting the time, making test transmissions etc. Operations include loading data for transmission, logging transmission status and exceptions, synchronizing clocks etc.

**Appendix E:  
Software  
Development Kit  
(SDK)**

## OVERVIEW

---

The Xpert Software Development Kit (SDK) enables developers to create Sutron Link Libraries (SLLs) that extend Xpert's functionality according to the developer's unique needs. The SDK is most often used to create libraries containing custom *setup blocks*, *property pages (tabs on the main screen)*, and *control panel entries* (branches in the tree under the Setup tab), but may also be used to create libraries that manipulate ports, files, peripherals, and any other entity accessible through standard Windows CE operating system API calls.

The SDK is may be downloaded from Sutron's website at:

<http://www.sutron.com/DownloadsUpdates/XpertSDK.htm>

The SDK is intended for use with Microsoft eMbedded Visual Tools (EVT) 3.0 which, at the time of this writing, is available at no charge from Microsoft. This toolset contains the compiler, linker, and operating system libraries necessary to develop for the Xpert platform. It may be ordered on CD from Microsoft (in which case a modest shipping charge applies), or downloaded from:

<http://www.microsoft.com/downloads/details.aspx?FamilyID=F663BF48-31EE-4CBE-AAC5-0AFFD5FB27DD&displaylang=en>.

Sutron assumes that any developer using the tools is already knowledgeable concerning C++ and basic Windows programming.

Please note that custom SLLs must be rebuilt (compiled and linked using EVT 3.0) whenever you upgrade to a new version of Xpert firmware. This must be done with the version of the SDK that matches the version of Xpert firmware.

# **Appendix F: Creating Custom Voice Files**

## OVERVIEW

---

Xpert speech files are binary data files containing audio data in Rockwell 4-bit ADPCM 7200hz mono format. These files are "headerless", meaning they have no information describing the content of the file, just sample data. Users can create these files using one of several aftermarket programs for the PC. One such program is "Vox Studio" by Xentec. This program allows the user to record speech using a microphone connected to the PC, and save it in the appropriate format (Rockwell 4-bit ADPCM 7200hz mono). The file can then be loaded into the Xpert using Xterm (into the corresponding language subdirectory under \flash disk\speech\, e.g., English, Spanish, etc.), and used by selecting it in a ComsTag dialog, just as you would any other speech file. (Note: You will need to save the file with a unique name and with the extension ".vox" so that the Xpert will display the file for selection).

The program "Vox Studio", by Xentec, is available for download at: <http://www.xentec.be/download/download.htm>. Note: the unregistered version of this program limits the length of files to 5 seconds. As of this writing, a fee of \$399 is required to register, which removes the limitation.

When using Vox Studio or any other editing program, Sutron recommends trimming off the leading and trailing silence to help reduce the size of the file. We also recommend using the normalize function to adjust the volume of the recorded phrase.

# **Appendix G: Autoexec.bat and Remote.exe**

## AUTOEXEC.BAT

---

Starting with version 2.0.0.0 and greater, the autoexec.bat file is AUTOMATICALLY updated by the system when changes to the COMS are made. The only time a user needs to modify the autoexec.bat file manually is if the autoexec.bat file is corrupted or missing.

The Xpert executes instructions in the \flash disk\autoexec.bat file on startup. If the file doesn't exist, or if the user cancels execution, the system will run \windows\remote.exe com1:115200. This remote.exe program is the program that allows communication with XTerm. With remote.exe running, you will be able to update the software, setups and monitor the system as needed.

To skip autoexec.bat on Xpert, touch the screen while turning on the Xpert and remain touching it until you see a message box displayed. The message box will ask if you want to skip the execution of autoexec.bat. Press YES. If you press NO, the system will continue and execute autoexec.bat.

To skip the autoexec.bat via a terminal program, connect a PC running a terminal program to COM1 and apply power to the unit. After the terminal displays "Flushing caches", press CTRL key and C <CTRL-C>, hold until message displays "Bypassing \flash disk\Autoexec.bat..."

The factory default for autoexec.bat is as follows:

```
\windows\remote.exe com1:115200
\windows\Xpert.exe
```

The first line runs remote.exe, enabling communications on com1. The second line runs the main Xpert application program. The details of running remote.exe are explained in the following section. Xpert.exe accepts several command line options:

```
/Debug      send debug messages to the serial port
/SDI COM4:  use COM4 for SDI-12
```

**NOTE:** If redirecting SDI to a different com port, the com port settings in the coms section of setup should be left as none. Coms is strictly for configuring remote and ssp devices.

You may make changes to the autoexec.bat by editing the file on your PC and then transferring it to the Xpert. However, if you make a mistake and render it inoperable, you will need to follow the instructions to skip autoexec.bat on startup so you can transfer a correct autoexec.bat to the Xpert.

## REMOTE.EXE

The system has a remote.exe in the \windows directory. However, it is possible to load an updated version into \flash disk and run it instead of the version in \windows. Remote can support different communications devices on each of its serial ports. All the ports are specified by the command line arguments when remote.exe is run.

Remote supports the following communications devices:

Name	Device	H/W Flow	Description
COMx	Direct connection to a PC	RTS/CTS	The Xpert is connected to a PC using a RS232 cable. Typically the PC will run XTerm, PCBASE2 or XCONNECT. Both a command prompt and SSP are available.
MODEMx	Commercial modem.	RTS/CTS	The Xpert is connected to a Hayes compatible telephone modem. No voice functions will be supported.
RADIOx	LOS Radio modem.	None	The Xpert is connected to a LOS radio modem. The Xpert can communicate with other stations and master stations on the radio network using SSP.
VOICEx	Sutron Voice/Modem.	RTS/CTS	The Xpert is connected to Sutron's Voice Modem. Both Voice and Data functions will be supported.
SSPx	SSP only direct connection	None (*)	The Xpert is connected to a Xpert, a Base Station PC, or another RTU that supports SSP using an RS232 cable. Typically the PC will run XTerm, PCBASE2 or XCONNECT.
RSx	RS-485 connection	None	The Xpert is directly connected to another Xpert using SSP.

Where x is the COM port number 1 to 4

(\*) H/W Flow control was enabled on SSP ports before version 2.3, and may be re-enabled if needed with the /HS option.

Remote also supports the following command line arguments:

Option	Description
/F UnitID	ID to respond to when receiving an SSP message (note this can be omitted if the user has set the station name.)
/T MasterID	ID to use in SSP message when sending an alarm

/HSx+	Force hardware RTS/CTS handshaking on, on port x. Use this to enable handshaking on a device mode which normally has it disabled (ie. RADIO or SSP).
/HSx-	Force hardware RTS/CTS handshaking off, on port x. Use this to disable handshaking on a device mode which normally has it enabled (ie. COM, MODEM, VOICE).
/DTRx+	Force DTR to be enabled all the time on port x when used in conjunction with a port in SSP: or COM: modes. In SSP: mode DTR is asserted whenever data is transmitted, and in COM: mode DTR is asserted whenever a connection is made. This switch has no effect on RADIO: mode where DTR is used to key the transmitter, or MODEM: or VOICE: mode where DTR is used to hangup the phone.
/DTRx-	Force DTR to be disabled all the time on port x, when used in conjunction with a port in SSP: or COM: modes.
/AUTOLOGON	Causes command prompt sessions to automatically login as the user name "AUTO" with no password. This can be used to limit access to the system, or to allow a custom command parser full control of the session.
/DEBUG	Disables resetting of unit by the software watchdog so it doesn't interfere with debugging code.

Example: the following command runs remote.exe to support a direct connection on COM1 and a Sutron voice modem on COM3:

```
\flash disk\remote.exe com1:115200 voice3:115200
```

It's usually not possible to place special command line options for Remote in the Autoexec.bat file because whenever a com port setting is changed in the Xpert application, the settings you make will be replaced. For this purpose extra command line options may be placed in a file called "Remote.opt". This is a simple ASCII text file that can be created with notepad and transferred to the Xpert and placed in the \Flash Disk folder. It can contain a single line of options that are concatenated to the parameters passed to Remote in the Autoexec.bat. So for instance, if you wished to enable AUTOLOGON and disable H/W handshake on port 2, you would place the following in the Remote.opt file:

```
/AUTOLOGON /HS2-
```

Remote.exe is designed to communicate with Sutron's XTerm program to provide a wide range of functions. In addition, you can use a terminal emulator with remote and issue one of the following commands. Note: if you have set up any usernames and passwords in the Xpert, you will be prompted to enter a username and password in order to issue commands to remote.exe

Table of remote commands:

Command	Description
ABOUT	Shows the same information as the Xpert's Status tab, About button
CD path	Change directory
DATE [mm-dd-yyyy]	Displays or sets the date
DEFAULT	Exits and runs \Windows\Remote COM1:115200
DEL file	Delete file
DIR path	Display directory
GET [sensor-list] [/F logfile] [/S mm-dd-yyyy hh:mm:ss] [/E mm-dd-yyyy hh:mm:ss] [/CSV] [/YMODEM] [/ZIP] [/C] [/REVERSE] [/BAD] [/INVERT] [/OLDEST] [/NEWEST] [/TODAY] [/YESTERDAY] [/WEEK] [/MONTH] [/YEAR] [/HOUR]	<p>Shows archived log data. Specifying a sensor-list will cause only those sensors to be displayed.</p> <p>/F specifies a logfile, SSP.LOG is used by default.</p> <p>/S specifies a start date and time for retrieval. If a start date is not specified then it will default to where the last GET left off.</p> <p>/E specifies an end date and time for retrieval. If an end date is not specified the end of the log is assumed.</p> <p>/CSV will use a comma-seperated format . /CSV will also show more decimal places (by default only 3 places are shown to help keep columns aligned).</p> <p>/YMODEM will cause the report to be transferred as &lt;sitename&gt;_YYYYMMDD.TXT, where &lt;sitename&gt; is the name of the station, and YYYYMMDD is the date of the first entry in the log. If the data is from a log other then SSP.log then the format of the file created will be as follows: &lt;sitename&gt;_&lt;logfile&gt;_YYYYMMDD.TXT.</p> <p>/ZIP will cause the output to be compressed in to a .ZIP archive file with a .ZIP extension.</p> <p>If there are more then 24 lines of output, the display will pause with a “- More -” prompt until space is pressed to continue, or ESC to abort</p> <p>/C will cause the output to be continuous (without pause) until the end is reached or ESC is pressed.</p> <p>/REVERSE will cause the output to be generated in reverse time order (newest to oldest).</p> <p>/BAD will cause only bad data, and system errors to be displayed.</p> <p>/INVERT will display all sensors that are not contained in the sensor-list.</p>

	<p>/OLDEST will start the dump with the oldest data in the log.</p> <p>/NEWEST will start the dump with the newest data in the log, especially useful when combined with /REVERSE.</p> <p>/TODAY will start the dump with today.</p> <p>/YESTERDAY will start the dump with yesterday.</p> <p>/WEEK will start the dump with the last Sunday.</p> <p>/MONTH will start the dump with the 1st of the current month.</p> <p>/YEAR will start the dump at Jan 1 of the current year.</p> <p>/HOUR will start the dump at the top of the current hour.</p>
HELP	Displays the list of commands.
INFO	Shows the same information as the Xpert's Status Tab
LOGOUT	Logout (also quit or exit)
MAIL [port to msg]	Reads or sends mail message
MD dir	Make a directory
MEASURE [...]	Measure works exactly the same as the SHOW command except it causes a live-reading of the sensor values to be taken before the results are displayed.
MEM	Display memory usage
PASSTHRU port:parity,bits,stop [/HW] [/ECHO] [/BREAK] [/CONTROL]	<p>Opens the specified COM port (either unopened or under the control of remote). Any characters typed are sent to the port. Any characters received are displayed. Terminate with by pressing ESC three times in a row.</p> <ul style="list-style-type: none"> <li>• The /HW option enables RTS/CTS h/w handshaking.</li> <li>• The /ECHO option causes the characters you type to be echoed back which can be useful when communicating with half-duplex devices.</li> <li>• The /BREAK option will send a 500ms break to the serial port after connecting. This may be used to wakeup sensors which require a break.</li> <li>• The /CONTROL option (added in version 2.10) allows the DTR control line to be passed through. This used to be the default behaviour, but as of 2.10 dropping DTR or disconnecting will cause a logout to occur.</li> </ul> <p>As of version 2.10, the normal user inactivity timeout will be applied to passthru sessions; previously a passthru session would not timeout.</p> <p>Note: If using passthru to access a port already under control of</p>

	Remote, then the existing port settings are always used. This includes hardware handshaking. If you try to communicate with a port with hardware handshaking enabled, and CTS is low preventing transmission, then the message [CTS LOW] is displayed.
RD dir	Remove a directory
REBOOT	Reboots the Xpert
RECORDING [on off]	The RECORDING command will display the current recording status. If “on” is specified then recording is turned on, likewise “off” will turn recording off.
REN old new	Rename a file
REPORT mode	Set status reporting to on, off, none, ssp[0-9], low, medium, high, i2c, all, debug. (more below)
SET sensor[:value] data	Sets the current value of a tag to the specified data. For tags with multiple possible values, the value number may be specified (1-n). Data may be an integer, a floating point number, or a double-quoted string.
SHOW [sensor-list] [/SENSOR/TAG] [/CSV] [/YMODEM] [/C]	<p>The SHOW command by itself will display the current value for every sensor and tag in the system in a tabular report. Sensors are the input blocks in the system. Tags include any intermediate or final value in the setup marked with a ComsTag, a custom tag created with Basic, or a Field Variable.</p> <p>Specifying a sensor-list will cause only those sensors and tags to be displayed (sensors and tags can have the same name).</p> <p>/SENSOR shows only sensors.</p> <p>/TAG shows only tags.</p> <p>/CSV will use a comma-separated and quoted format that can be imported in to a spreadsheet. /CSV will also show more decimal places (by default only 3 places are shown to help keep columns aligned).</p> <p>/YMODEM will cause the report to be transferred using the Ymodem protocol as &lt;sitename&gt;_show.TXT, where &lt;sitename&gt; is the name of the station.</p> <p>If there are more than 24 lines of output, the display will pause with a “- More -” prompt until enter is pressed to continue, or ESC to abort. The [/C] option will cause the output to be continuous (without pause) until the end is reached or ESC is pressed.</p> <p>The alarm status of each tag is displayed. More than one alarm condition may be displayed. The following codes are common: OK – not in alarm A - in alert (transmitting)</p>

	H - high limit exceeded L - low limit exceeded D - rate of change exceeded
SHUTDOWN	Causes the Xpert program to exit so that Xpert.exe, DLLs, and SLLs may be upgraded.
STARTUP	Runs Xpert.exe from the \Flash Disk folder if it's there, otherwise from the \Windows folder. Updates the AUTOEXEC.BAT if the location has moved.
STATION [name]	The STATION command will displays station's name. If a name is passed to the command, then the station name will be set and the change will take effect immediately.
STATUS [clear]	Display and or clear com port status
STOP name	Stops a process forcibly
TASKS	Displays tasks and heap usage
TERMINATE	Exits Remote, which in turn terminates all remote communications being handled by Remote. This command has been removed from version 2.10 and later because improper use can lead to becoming locked out of a remote unit.
TIME [hh:mm:ss]	Displays or sets the time
TYPE file [/C]	Display a file to the screen. If the file is longer then 24 lines the display will pause with a “- More -” prompt until enter is pressed to continue, or anything else to abort.  The [/C] option will cause the output to be continuous (without pause) until the end is reached or ESC is pressed.
OLDUPGRADE	When running \Windows\Remote.exe this command exits and upgrades to a new version of Remote downloaded to the \Flash Disk folder.  When running \Flash Disk\Remote.exe this command exits and downgrades to the original version in \Windows. In either case, command line settings are retained.
UPGRADE [/YES] [/P]	The UPGRADE command is used to upgrade system files using the Ymodem protocol. This previous version of this command is now called “OLDUPGRADE”. An “upgrade” can consist of a single new file to add to the system, or complete set of application files contained in a .ZIP file. The upgrade command cannot upgrade the kernel or the loader, only application files such as Xpert.exe, Remote.exe, DLLs, SLLs, .BAS files, etc are supported. The .UPG file used to perform upgrades with XTerm is not used. The user is prompted “Are you sure?” and must respond with a “Y” or “y” before the upgrade proceeds. Following are the steps performed:

	<p>The Xpert application is shutdown.</p> <p>Any old application files on the \Flash Disk are deleted. This includes Xpert.exe, *.DLL, and *.SLL.</p> <p>The file transfer is performed.</p> <p>The file or file(s) are then stored on the \Flash Disk.</p> <p>If the currently executing Remote.exe needs to be replaced, then Remote will shut itself down and restart the new version. This will drop the current connection.</p> <p>The Autoexec.bat file will be verified and/or modified to make sure that the correct version of Xpert.exe is executing (\Flash Disk\Xpert.exe if it exists, otherwise \Windows\Xpert.exe)</p> <p>The Xpert application is re-started (the one stored in the \Flash Disk folder if it exists, otherwise the one in the \Windows folder).</p> <p>Options:</p> <p>The /YES option will bypass the “Are you sure? ” prompt.</p> <p>The /P option enables a partial upgrade for situations where just some of the files are being changed. Step 2 (the deletion of files) is skipped. This option can be used to download a new version of Remote, or to add some new .SLL files, or .BAS files.</p>
VER	Displays the build date Remote was created
YMODEM [file-list] [/ZIP]	<p>With no options specified, the YMODEM command will receive files using the Ymodem protocol and store them on the Xpert. If the file being transferred has a .ZIP extension, then it will be automatically expanded and the contents stored in the current folder (typically \Flash Disk).</p> <p>The command may be used to send files using the Ymodem protocol by supplying a file name or a file-list. A file-list is simply a list of files to send (delimited by spaces; use quotes around files containing spaces).</p> <p>/ZIP may be used when sending files to cause the files to be compressed in to a .ZIP archive before being transferred. The name of the archive will be the same as the first file in the list with a .ZIP extension.</p> <p>A transfer can be aborted by pressing ESC 3 times.</p>

The command prompt supports a 10-line command recall capability invoked by pressing UP ARROW to scroll back through old commands, or DOWN ARROW to scroll to newer commands.

Most all commands support the /YMODEM, /ZIP, and /C options. Unless stated otherwise the default filename for the output of a command will be station\_command.txt for a /YMODEM transfer or station\_command.zip for a /ZIP transfer.

When a command displays more than 24 lines of output, the “– More –” prompt will be displayed. The user may press space to display another 24 lines, enter to display the next line, or C to start displaying lines continuously without break. The “more” mode of output may be re-enabled at any time by pressing M. Output may be terminated by pressing ESC.

The “REPORT” command defines message filters in Remote and in Xpert. Reporting requires extra processing that will slow operation of the unit. The options can be combined. For example to monitor COM2 for SSP messages, watch I2C messages, and observe debug messages, try the command:

```
\Flash Disk> report SSP2 I2C Debug
Reporting enabled and filter is set
```

Here’s a summary of what types of messages each option will display:

None or Off	No messages
SSP	SSP messages from any communication port, and error, warning, and status messages. SSP messages are decoded. SSP messages over TCP/IP are not displayed.
SSPn	SSP messages from the specified communication port, ie SSP4 would show messages to/from COM4.. If SSP0 is specified then SSP messages transported by TCP/IP are displayed.
Low	Error messages
Medium	Error and warning messages.
High	Error, warning, and status messages.
All or On	Debug, error, warning, status and SSP messages from serial ports 1 through 9.
Debug	Debug, error, warning, and status messages.
I2C	Decoded I2C messages

The SSP Decoder displays the time of a message, the source and destination, the sequence number, the operation code, the size of the message, and partial decoding of the contents of the message.

```
SSP Decoder Example:
\Flash Disk> report SSP2
17:16:38 COM2: RTU>XCONNECT 4865191 TimeTag,16,09/18/2006
17:14:00,String,BAT,Real,12.529999 | TimeTag,20,09/18/2006
17:14:00,String,AirTemp,Real,72.799988 | TimeTagEnd,0
17:16:39 COM2: XCONNECT>RTU 11720692 Ack,1,TimeTagEnd
```

```

17:16:39 COM2: XCONNECT>RTU 11720942 SetClock,6,09/19/2006
17:16:42
17:16:45 COM2: XCONNECT>RTU 11721942 CurdataReq,0
17:16:45 COM2: RTU>XCONNECT 4871422
Curdata,30,BAT,2,0,Nil,1,Alarm,OK

```

## ABOUT Command Example

```

\Flash Disk> ABOUT
File                               Version
=====                           =====
Xpert                              2.5.0.15
Kernel                             3.3 (20050823)
Loader                             2.8 (20050809)
Remote                              2.5.0.15
\Windows\Xpert.exe                 2.5.0.15
\Windows\Engine.dll                2.5.0.15
\Windows\Logger.dll                2.5.0.15
\Windows\LogMgr.dll                2.5.0.15
\Windows\Lzo.dll                   2.5.0.15
\Windows\SDI.dll                   2.5.0.15
\Windows\Utils.dll                 2.5.0.15
\Windows\Basic.sll                 2.5.0.15
\Windows\Coms.sll                  2.5.0.15
\Windows\DefLib.sll                2.5.0.15
\Windows\SatLink.sll               2.5.0.15
\Windows\EzSetup.sll               2.5.0.15

```

## Get Command Example

The Get command shows the data logged, picking up where the last Get left off (or end of log, if the first time run).

```

\Flash Disk> GET
[SSP.LOG]
10-26-2005 13:45:00 STAGE           1.20 G ft
10-26-2005 13:45:00 AIRTEMP        78.20 G F
10-26-2005 14:00:00 STAGE           1.21 G ft
10-26-2005 14:00:00 AIRTEMP        78.25 G F
10-26-2005 14:15:00 STAGE           1.22 G ft
10-26-2005 14:15:00 AIRTEMP        79.10 G F
10-26-2005 14:30:00 STAGE           1.20 G ft
10-26-2005 14:30:00 AIRTEMP        79.00 G F
10-26-2005 14:45:00 STAGE           1.20 G ft
10-26-2005 14:45:00 AIRTEMP        78.60 G F

```

The following shows the most recent data followed by older data:

```

\Flash Disk> GET /NEWEST /REVERSE
[SSP.LOG]
10-26-2005 14:45:00 AIRTEMP        78.60 G F
10-26-2005 14:45:00 STAGE           1.20 G ft
10-26-2005 14:30:00 AIRTEMP        79.00 G F
10-26-2005 14:30:00 STAGE           1.20 G ft

```

```

10-26-2005 14:15:00 AIRTEMP      79.10  G F
10-26-2005 14:15:00 STAGE       1.22   G ft
10-26-2005 14:00:00 AIRTEMP      78.25  G F
10-26-2005 14:00:00 STAGE       1.21   G ft
10-26-2005 13:45:00 AIRTEMP      78.20  G F
10-26-2005 13:45:00 STAGE       1.20   G ft

```

The following shows all bad stage data that occurred today:

```

\Flash Disk> GET STAGE /BAD /TODAY
[SSP.LOG]
10-26-2005 05:45:00 STAGE       1.01   B ft
10-26-2005 05:45:00 STAGE       1.24   B ft

```

The following shows all entries in the system log for the current week:

```

\Flash Disk> GET /F SYSTEM /WEEK
[SYSTEM.LOG]
10-23-2005 01:05:05 NOTE (Stat) - User Bob logged in.
10-23-2005 01:06:50 NOTE (Stat) - Loaded \Flash Disk\543.ssf
setup file.
10-23-2005 01:05:05 NOTE (Stat) - Running.

```

The following sends the last month of AIRTEMP and STAGE data via Ymodem to the PC in CSV format:

```

\Flash Disk> GET AIRTEMP,STAGE /F SSP /MONTH /CSV /YMODEM
Ready to send YModem file(s) (press ESC to abort)

```

Ymodem all non-STAGE data from August. ZIP it first to reduce the amount of data that needs to be transferred.

```

\Flash Disk> GET STAGE /INVERT /S 08-01-2005 /E 08-31-2005 /ZIP
Ready to send YModem file(s) (press ESC to abort)

```

### INFO command Example

```

\Flash Disk> INFO
Recent Status:
  10/26 13:42 (Stat) - Remote user Bob logged in.
  10/26 13:42 (Stat) - Remote user Bob logged out. Active for 104
sec.
Com Status: Stopped
Memory Load 51 percent
Total Physical 7725056
Available Physical 3833856
Total Virtual 33554432
Available Virtual 29163520
Number of resets: 110
I2C STATISTICS:
#Rx:22  #Error:0  #Fail:0
#Tx:31  #Error:0  #Fail:0
NAK:0  TIMEOUT:0
COLLISN:0  OVRFLOW:0
BUSERR:0  RXERROR:0

```

```
SLAVETX:0 CHKSUM:0
STOP:0 BUSBUSY:0
RESTART:0 BADCHAN:0
Network Configuration
  DNS Servers . . . . . : 192.168. 168.1
  Ethernet adapter. . . : CS8900A1
  IP Address. . . . . : 192.168. 168.10
  Subnet Mask . . . . . : 255.255.255.0
  Default Gateway . . . : 192.168.168.1
```

### MAIL Command Example

```
\Flash Disk> MAIL
Mailbox for COM2:
10/26/2005 16:23:53 Mail from: BASE, Remember to cal the 4-20
input!
10/26/2005 16:23:18 Mail from: BASE, This is a test mail message.
\Flash Disk> MAIL 2 BASE All taken care of, I'm leaving the site
now.
Mail delivered.
```

### MEASURE/SHOW Command Example

The following measures all sensors and tags:

```
\Flash Disk> MEASURE
SENSOR
  BATVAL (Battery)          12.781 G V
  BATVAL (Temp)             28.767 G C
  STAGE                      1.23 G ft
  AIRTEMP (Temp)            78.32 G F
  AIRTEMP (Humid)           25.32 G %
TAG
  STAGE                      1.23 G H A
  AIRTEMP                    78.32 G OK
```

Show just the AIRTEMP tag

```
\Flash Disk> SHOW AIRTEMP /TAG
AIRTEMP                      78.32 G OK
```

Zip up the results of a show and transfer it to the PC using Ymodem.

```
\Flash Disk> SHOW /ZIP
Ready to send YModem file(s) (press ESC to abort)
```

Show all the sensor values in comma-seperated format

```
\Flash Disk> SHOW /CSV /SENSOR
BATVAL (Battery), 12.7813835841049,G,V
BATVAL (Temp), 28.7679583945093,G,C
STAGE, 1.23,G,ft
AIRTEMP (Temp), 78.3253939059343,G,F
AIRTEMP (Humid), 25.3246839763986,G,%
```

## PASSTHRU Command Example

```
\Flash Disk> PASSTHRU COM3:2400,N,8,1
Passthru operation has begun (press ESC ESC ESC to abort)
AT
OK
```

## RECORDING Command Example

```
\Flash Disk> RECORDING OFF
Stopping.
Recording is OFF
\Flash Disk> RECORDING ON
Running.
Recording is ON
```

## SET Command Example

- The following turns a pump called PUMPON on (set it to 1):

```
\Flash Disk> SET PUMPON 1
\Flash Disk> SHOW PUMPON /TAG
PUMPON                1      G OK
```

Turn a pump called PUMPON off (set it to 0)

```
\Flash Disk> SET PUMPON 0
\Flash Disk> SHOW PUMPON /TAG
PUMPON                0      G OK
```

## SHUTDOWN Command Example

```
\Flash Disk> SHUTDOWN
Stopping.
The Xpert application has been shutdown.
```

## STARTUP Command Example

```
\Flash Disk> STARTUP
Xpert has been started.
```

## STATION Command Example

```
\Flash Disk> STATION site123
The station is named site123
```

## STATUS Command Example

```
\Flash Disk> STATUS
COM1:115200,3.0,3,10.0,1.0 - bob(1) is logged in | Cmd: \Flash Disk>status
  SSP STATS: RX: 959, TOTAL: 959, BAD: 0 TX: 574, BAD: 0, FAIL: 0
RADIO2:9600,10.0,3,30.0,0.1 - Unknown(0) is logged out | Cmd:
  SSP STATS: RX: 2027, TOTAL: 2027, BAD: 0 TX: 1996, BAD: 0, FAIL: 0
VOICE3:115200,3.0,3,10.0,1.0 - Unknown(0) is logged out | Cmd:
```

## UPGRADE Command Example

```
\Flash Disk> UPGRADE
```

```
Are you sure? Yes
Stopping.
The Xpert application has been shutdown.
Ready to receive YModem file(s) (press ESC to abort)
(ymodem send the new file or files in a .zip archive)
Upgrade complete: Restarting Xpert.
```

## **YMODEM Command Example**

The following sends a file from your PC and place it on the Xpert using the Ymodem protocol:

```
\Flash Disk> YMODEM
Ready to receive YModem file(s) (press ESC to abort)
```

The following gets the files PUMP.BAS and FLUME.BAS from the Xpert and transfer them to your PC using the Ymodem protocol:

```
\Flash Disk> YMODEM PUMP.BAS FLUME.BAS
Ready to send YModem file(s) (press ESC to abort)
```

Get all setup files from the station, ZIP them up, and transfer them to your PC using the Ymodem protocol

```
\Flash Disk> YMODEM *.SSF /ZIP
Ready to send YModem file(s) (press ESC to abort)
```

# APPENDIX H: DIMENSIONS

# XPERT DATA LOGGER

Dimensions shown are in inches:

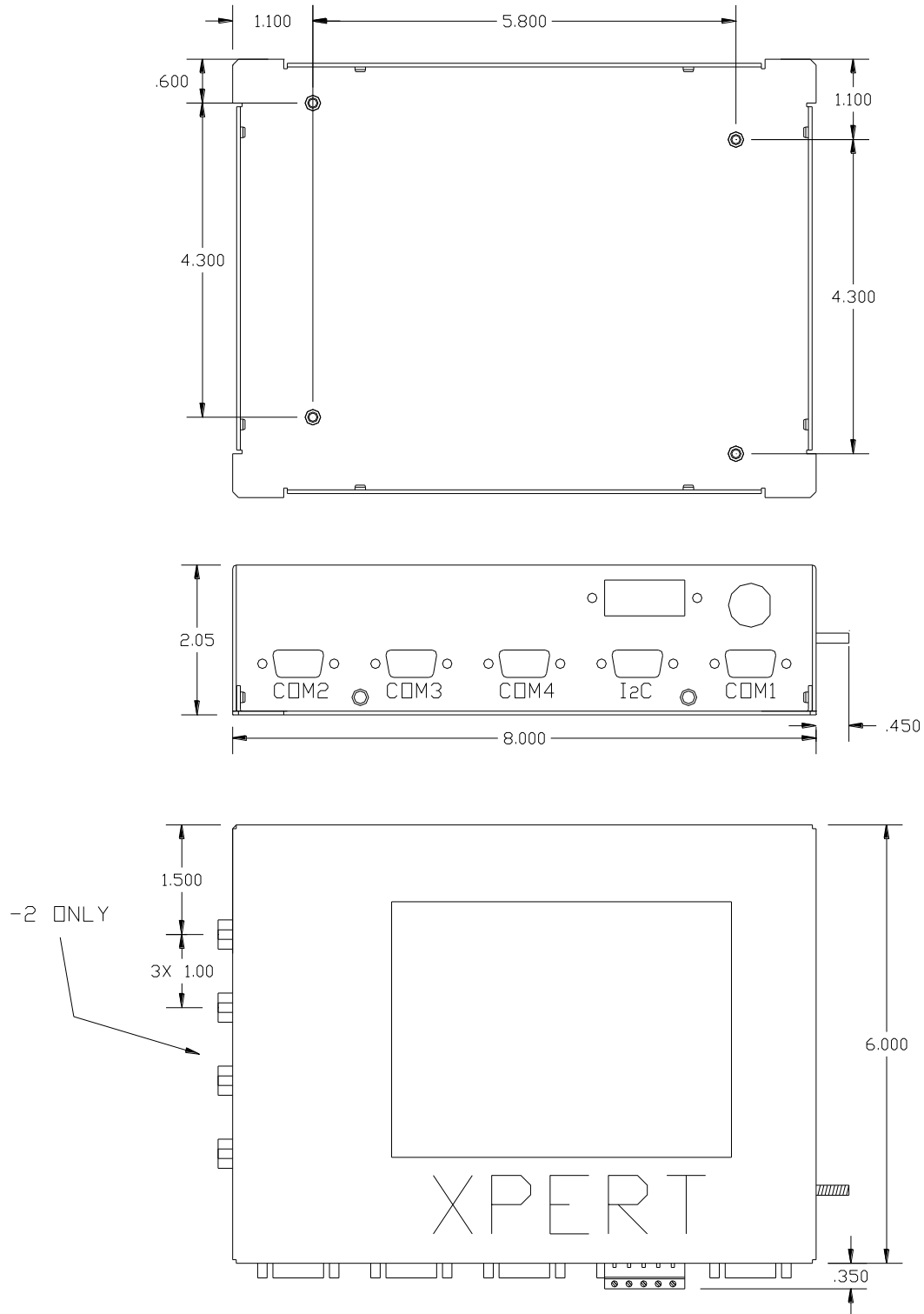

# I/O MODULES

Dimensions shown are in inches:

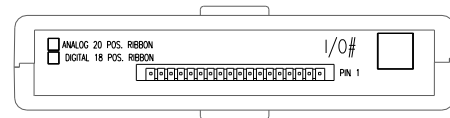
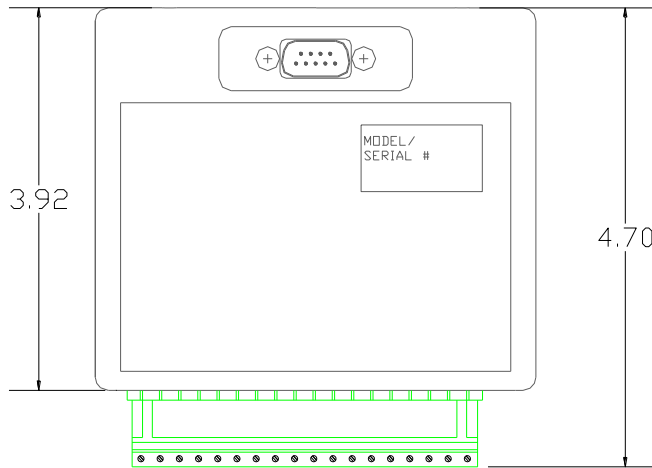
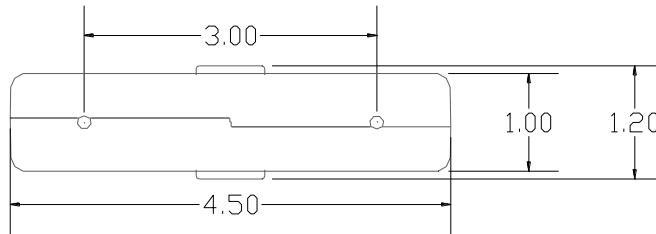

# XPERT MODEM

Dimensions shown are in inches:

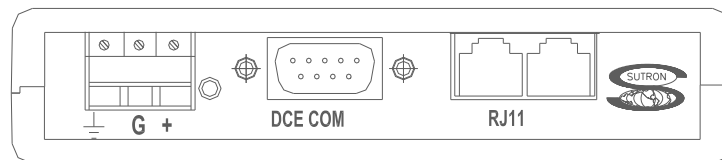
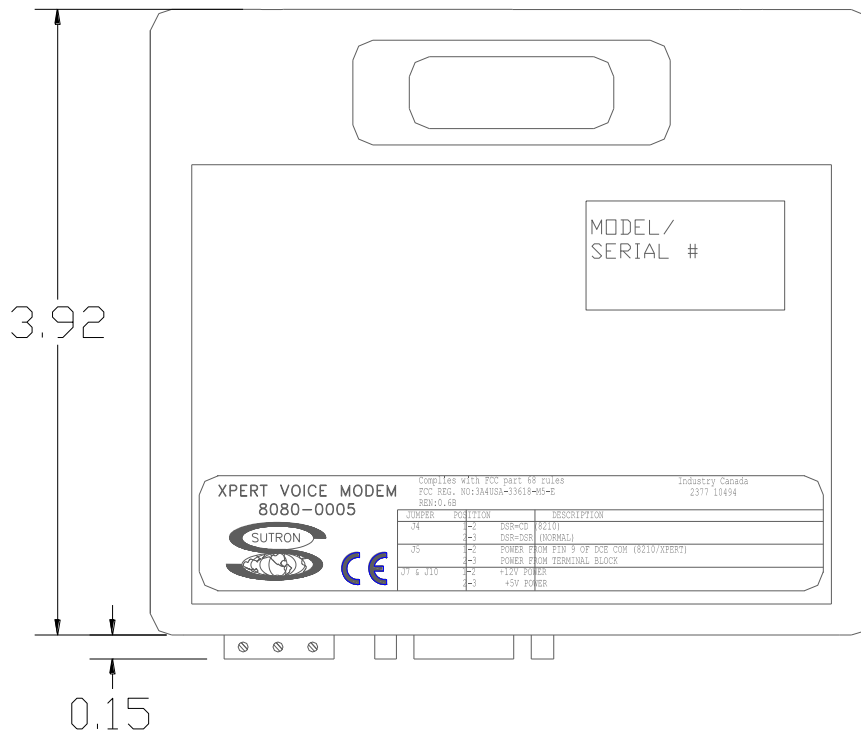
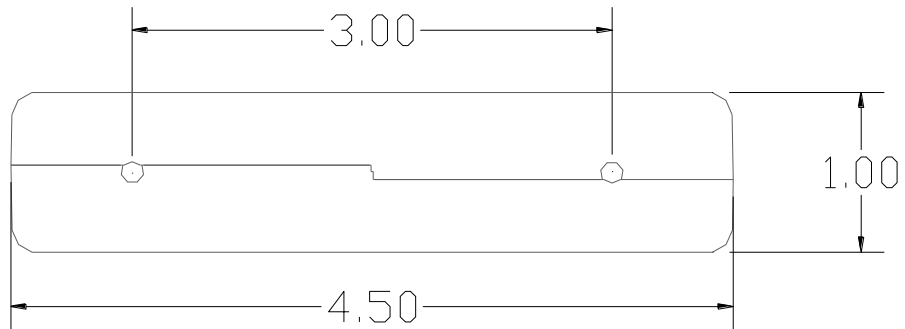



## Index

### 5

5600-0600, 163  
5600-0601, 163  
5600-0602, 163  
5600-0603, 163  
5600-0605, 163  
56-109 Submersible Pressure Transducer,  
165

### 8

8080-0000-1, 5, 229  
8080-0001-1, 5, 229  
8080-0002, 225  
8080-0002-1, 5  
8080-0002-2, 5  
8080-0003, 220  
8080-0003-1, 5  
8080-0005-1, 5, 230  
8080-0006-1, 144

### A

About dialog, 61  
access levels, 16, 51  
accounts  
    managing, 50  
    overview, 16  
    users.dat, 106  
accuracy  
    Analog I/O module, 223  
ADC block, 121–27  
Air Temperature sensor block, 119  
Air Temperature/Relative Humidity sensor  
    block, 121  
Alarm block, 21, 170  
alarms  
    block, 170  
    configuring, 20–31, 44, 45, 145, 170,  
    196, 197, 207  
    Digital I/O features, 227  
    Digital I/O Module features, 225, 227  
alerts, 20–31  
Analog block, 121–27  
Analog I/O Module, 220

accuracy, 223  
configuration examples, 224  
features, 220  
inputs, 222  
measurements, 222  
operational states, 222  
outputs, 222  
plug assignments, 220  
appending  
    random transmissions, 44  
    self-timed transmissions, 42  
Aquatrak block, 158  
AT/RH block, 121  
Auto Update, 98  
autoexec.bat, 114, 236  
Average Block, 173, 177

### B

bad data quality, 58  
Barometric Pressure sensor block, 128  
battery  
    Internal Battery block, 148, 149  
    replacing, 115  
BEIEnc block, 129  
Bin\_Int format, 43, 45  
Bin\_NonInt format, 43, 45  
Binary Input – All Channels block, 132  
Binary Input block, 130  
binary input mode, 132  
Binary Out block, 205, 206  
BinIn block, 130  
BinInAllChan block, 132  
BinOut block, 205, 206  
blocks  
    adding, 70–73  
    categories, 67  
    connecting, 68  
    control blocks. *See* control blocks  
    deleting, 78  
    inputs and outputs, 68  
    log blocks. *See* log blocks  
    miscellaneous blocks. *See* miscellaneous  
    blocks  
    overview, 3

processing blocks. *See* processing blocks  
properties, 68, 73  
sensor blocks. *See* sensor blocks  
telemetry blocks. *See* telemetry blocks  
wiring, 76  
Bool, 175  
BP block, 128  
Bridge Resistance block, 134  
Burst, 45  
Burst Int, 44

## C

calibrate  
  sensors  
    XPert, 52  
    touchscreen, 114  
CapRain block, 135  
Center in Window, 42  
channel  
  binary input, 130  
  random, 45  
  self-timed, 42  
cleaning, 115  
clearing log, 59  
Com ports  
  configuring, 20–24  
COM ports  
  pin assignments, 109–110  
  testing, 24  
Communication Test Menu, 24  
Coms Tag block, 21, 196  
COMx, 237  
connection settings in XTerm, 98  
Constant block, 137  
ConstIn block, 137  
contrast, 16  
  adjusting from Login screen, 9, 115  
  adjusting from Main tab, 18, 115  
control blocks. *See Also* blocks  
  Binary Out, 205  
  Pulse Out, 206  
Control Panel tab, 20–51  
count, 173, 177  
Counter block, 138  
Counts per Turn drop down box, 154  
CS107 Temperature sensor block, 140

CS505 Fuel Moisture sensor block, 144  
current measurement, 122, 126

## D

data column (log file), 58  
data modem. *See* modems:data modem  
date  
  column (log file), 59  
  setting, 17  
Day buttons, 59  
Deleting a Block, 78  
Deleting Multiple Blocks, 79  
Dial-In Commands, 27  
Dial-Out Commands, 27  
Digital I/O Module, 225  
  counters, 226  
  digital filters, 226  
  features, 225  
  frequency, 227  
  inputs, 226  
  outputs, 227  
  plug assignments, 226  
  shaft encoders, 227  
  specifications, 225  
direct connect, 20–25  
Display block, 208  
DLLs, 3  
  overview, 3  
  updating, 216  
DoubleVolts, 125

## E

enable  
  excitation channel, 127  
  random transmissions, 44, 199  
  self-timed transmissions, 42  
  temperature, 128  
excitation channel, 127  
exit, 62  
exporting log files, 58, 59  
EzSetup Measurements, 31  
  overview, 3

## F

Field Variable blocks, 55, 209  
File Transfer, 95

Find button, 53, 59  
Flash file system  
  initializing, 215  
FM block, 144  
formats, transmission, 43, 45  
Freq block, 142, 176  
Frequency block, 142  
Fuel Moisture sensor block, 144  
fuses, 116

## G

GetTag block, 145  
Gill Wind block, 146  
good data quality, 58  
Graycode input mode, 132  
GUI  
  operation, 15–62  
  updating, 216

## H

Hi Alarm, 171

## I

I/O Modules, 3, 9, *See* Analog I/O  
  Modules, Digital I/O Modules  
I<sup>2</sup>C Modules specifications, 229  
Initialize Satlink, 41  
Insert a Block, 79  
installation  
  autoexec.bat, 236  
  COM ports, 109–10  
  remote.exe, 237  
  XPert, 106–8  
  XTerm, 90  
Internal Battery block, 148, 149  
Interpolate block, 179, 181

## K

kernel  
  updating, 216

## L

Lat/Lon, 42, 44  
linear sensors, 119  
live measurements, 52

loader  
  updating, 215  
log blocks, 194, *See Also* blocks  
log files  
  blocks. *See* log blocks, blocks  
  clearing, 59  
  creating, 39  
  data column, 58  
  date column, 59  
  Day buttons, 59  
  directory, 39  
  exporting, 58, 59  
  Find button, 59  
  managing, 38  
  navigating, 59  
  properties, 39  
  Q (quality) column, 58  
  selecting, 59  
  sensor column, 58  
  time column, 58  
  units column, 59  
  viewing, 58  
login, 16  
logout, 16, 19  
LOS Radio modem. *See* modems:LOS  
  radio modem  
Low Alarm, 171

## M

Main tab, 17–19  
maintenance, 19, 114  
max, 172, 173  
Measure block, 182  
measurements  
  analog, 121–27, 222  
  live, 52  
min, 172, 173  
Minimum/Maximum block, 183  
miscellaneous blocks. *See Also* blocks  
  Display, 208  
  Set Field Variables, 209  
models, 5  
modems  
  data modem, 30  
  installation, 106–8, 109–10  
  LOS Radio modem, 30, 230

speech modem, 5, 25–27, 229  
MODEMx, 237  
Moving Average block, 184  
multiplier, 142

## N

NESDIS, 43  
NFDRS format, 43  
NIFC format, 43  
Norm Rate, 44  
NOS format, 43

## O

operation, 15–62

## P

passwords, 16, 51  
period, 142  
Platinum RTD block, 152  
Polynomial block, 185  
powering up, 9  
Precip block, 166  
precision, 75  
prefix, 196  
Process List Folder, 96  
processing blocks. *See Also* blocks  
  Alarm, 170  
  Average, 172, 173, 177  
  Boolean, 175  
  Interpolate, 179, 181  
  Measure, 182  
  Minimum/Maximum, 183  
  Moving Average, 184  
  Point Control, 186  
  Polynomial, 185  
  Set Point Control, 188  
  Solar Radiation Accumulation block,  
    189  
  Vector Average, 191  
  XY Function, 193  
PtCtrl, 186

## Q

Quadrature Shaft Encoder block, 154  
quality

appending to random transmission, 44  
appending to self-timed transmission, 42  
column (log file), 58

## R

radio modem. *See* modems:LOS Radio  
  modem  
RADIOx, 237  
Random Group block, 197  
Random Parameter block, 199  
Random Properties, 43  
Random Test, 46  
Rate, 43, 44  
recording status  
  XPert, 18  
Refresh button, 47, 61  
remote.exe, 236, 237  
Reset button, 38, 47  
Reset FS button, 47  
resistance measurements, 122, 124, 126  
RM Young Wind Sensor block, 155  
RndGroup block, 197  
ROC Alarm, 171  
RS232 modules specifications, 229  
RS-485, 5, 22, 30, 111

## S

sample  
  duration, 173, 178  
  interval, 173, 178  
satellite ID, 41  
Satlink  
  description, 230  
  installation, 106–8, 109–10  
  properties, 40  
  random properties, 43  
  random test, 46  
  self-timed properties, 41  
  **self-timed test**, 45  
  Status, 47  
schedule  
  interval, 173, 178  
  time, 173, 178  
SDI AquaTrak block, 158  
SDI-12. *See Also* Digital I/O Modules  
  commands, 53

- SDI-12 block, 157
- SDIAqua block, 158
- SDK, 232, 234
- SE8500 block, 159
- Self-Timed Parameter block, 200
- Self-Timed properties, 41
- Self-Timed Test**, 45
- SendTag block, 207
- sensor blocks. *See Also* blocks
  - Air Temperature, 119
  - Air Temperature/Relative Humidity, 121
  - Analog, 121–27
  - Barometric Pressure, 128
  - BEI Absolute Encoder, 129
  - Binary Input, 130
  - Binary Input - All Channels, 132
  - Bridge Resistance, 134
  - CapRain, 135
  - Constant, 137
  - Counter, 138
  - CS107 Temperature Sensor, 140
  - Frequency, 142, 176
  - Fuel Moisture, 144
  - GetTag, 145
  - Gill Wind, 146
  - Internal Battery, 148, 149
  - Platinum RTD, 150, 152
  - Quadrature Shaft Encoder, 154
  - R.M. Young Wind, 155
  - SDI AquaTrak, 158
  - SDI-12, 157
  - SE8500, 159
  - Soil Moisture, 160, 161
  - Solar Radiation, 163
  - Submersible Pressure Transducer, 165
  - Tipping Bucket, 166
  - Volt Meter, 168
- sensor column (log file), 58
- sensors
  - calibrating, 52
  - live measurements, 52
  - properties, 52
  - sending SDI-12 commands, 53
  - viewing, 52, 54
- Set Clock. *See Also* date:setting, time:setting
  - XTerm control, 97
- Set Field Variables block, 209
- Set Point Control block, 188
- SetFieldVar block, 209
- SetPoint block, 188
- setup. *See Also* blocks
  - blocks. *See* blocks
  - example, 67
  - new, 70
  - setup blocks. *See* blocks
- Shaft Encoder block, 154
- SHEF format, 43
- SLLs, 232
- Software Development Kit, 232, 234
- Soil Moisture block, 160, 161
- Solar Radiation Accumulation block, 189
- Solar Radiation sensor block, 163
- specifications
  - basic unit with display, 229
  - basic unit without display, 229
  - Digital I/O Module, 225
  - I<sup>2</sup>C modules, 229
  - RS232 modules, 229
- speech
  - Coms Tag block, 196
  - files
    - creating, 234
    - loading, 106
  - introduction, 21
  - modem. *See* modems:speech modems
  - phrases, 26–29
- SR block, 163
- SSP, 145, 196, 207
- standard deviation, 172, 173, 177
- station name
  - XPert, 18
- Status button, 46, 47
- Status Options dialog, 61
- STD, 172, 173, 177
- Submersible Pressure Transducer block, 165
- SubPres block, 165
- suffix, 196
- Sutron Link Libraries, 232
- Sutron Speech/Voice modem. *See* modems:speech modem

## T

telemetry blocks. *See Also* blocks  
  Coms Tag, 196  
  Random Group, 197  
  Random Parameter, 199  
  Self-Timed Parameter, 200  
  SendTag, 207  
Telemetry modules, 5  
temperature sensor block. *See* Air  
  Temperature sensor block, Air  
  Temperature/Relative Humidity sensor  
  block, CS107 Temperature sensor block  
Test check box, 137  
tests  
  communication, 24  
  I/O Modules, 9  
  initial, 9–12  
  random, 46  
  **self-timed**, 45  
  touchscreen, 9  
thermistor, 119, 124, 140  
time, 43  
  column (log file), 58  
  setting, 17, 97  
Tipping Bucket Sensor block, 166  
touchscreen  
  calibrating, 114  
troubleshooting, 114  
Type, 43, 45

## U

units column (log file), 59  
unpacking, 8  
update  
  application, 216  
  extension, 216  
  Flash file system, 215  
  kernel, 216  
  loader, 215  
  remote.exe, 237  
Upgrade, 98

users, 16, 48, 49, 50

## V

VectAvg block, 191  
Vector Average block, 191  
View Data tab, 54  
View Log tab, 19–51  
voice modem. *See* modems:speech modem  
VOICEx, 237  
Volt Meter block, 168  
voltage measurement, 122, 126  
VoltMeter block, 168

## W

Web Server, 98  
window, transmission time, 43  
Wire button, 77, 78  
wiring, 76  
wrap, 39

## X

XPert  
  installation, 106  
  models, 5  
  picture, 4  
  product description, 4  
XTerm. *See Also* remote.exe  
  auto update, 98  
  connect, 98  
  file transfer, 95  
  installation, 90  
  introduction, 90  
  operating, 93  
  preparing the XPert to work with  
    XTerm, 93  
  set clock, 97  
  Upgrade, 98  
  web server, 98  
XY Function block, 193  
XYFunct block, 193